

RADIO AGE

The Magazine of the Hour

Price
25 cents

JULY, 1923

IN THIS NUMBER

The Grimes Inverse Duplex System

By Frank D. Pearne

How to Read and Follow Symbols

Hook-ups and Pick-ups

By Our Readers

Complete Corrected List of Broadcasting Stations

Many Good Circuits!



OFFICIAL NEWS MEDIUM FOR NATIONAL BROADCASTERS' LEAGUE

Reinartz Radio

How to make this distance wrecker.
How to amplify it.
How to make a Reinartz panel.

With Hook-ups

Written and Illustrated by
FRANK D. PEARNE

*Chief Instructor in electricity at Lane Technical High
School, Chicago, and famous writer on radio
construction and operation.*

Experts agree this Reinartz Hook-up
is best for average fan.

Hook-up for the Long Distance Crys-
tal Set—They are all trying it.

Get this book of the 1922-23 Season

Published by
RADIO AGE, Inc.
500 N. Dearborn Street
CHICAGO

*AT YOUR NEWSDEALERS' OR SEND MONEY ORDER
OR CURRENCY TO PUBLISHER*

—≡ **Price 50 cents** ≡—

While they last—This booklet and year's subscription
for only \$2

RADIO AGE

The Magazine of the Hour

Volume 2

JULY, 1923

Number 6

CONTENTS

	Page
The Grimes Inverse Duplex System..... BY FRANK D. PEARNE	2-3-4
Hook-ups and How to Read Them..... BY FELIX ANDERSON	5-6-7
Proper Antenna for Tuning..... BY F. CONRAD	8
The Passing of an Old Friend..... BY LLOYD JACQUET	9
WJAZ, A Station with a Difference.....	11
Thought Waves from the Editorial Tower.....	12
Little Things that Help..... (Illustrated)	14
The Trouble-Shooter..... (Illustrated Questions and Answers)	15-16-17-18
Pick-up Records from our Readers..... (Illustrated)	19
Complete Correct List of U. S. and Canadian Broad- casting Stations.....	29-30-31-32

RADIO AGE is published monthly by
RADIO AGE, INC.

Publication office, Mount Morris, Ill.
Editorial and Advertising Offices, Boyce Building,
500 N. Dearborn St., Chicago

FREDERICK SMITH, *Editor*
FRANK D. PEARNE, *Technical Editor*
M. B. SMITH, *Business Manager*
JOHN DOLL, *Circulation Director*

Western Advertising Representatives:
BRUNS & WEBBER
First National Bank Building, Chicago.

Advertising Forms Close on 5th of the Month
Preceding Date of Issue.

Issued monthly. Vol. 2, No. 6. Subscription price \$2.50 a year.
Entered as second-class matter September 15, 1922, at the post office at Mount
Morris, Illinois, under the Act of March 3, 1879.

Copyright, 1923, by RADIO AGE, Inc.

Radio "Pirates"

THIS magazine, from the first, has insisted that no publication, individual or corporation that favors turning radio merchandise, radio manufacturing and radio broadcasting over to a monopoly can by any perversion of logic be called a friend of radio.

There should be no monopoly in tubes, sets or broadcasting stations. There should be no special privileges. There should be no patience with efforts to establish monopoly through incessant patent suits against the weaker fellows.

Radio belongs to the millions and not to a few big corporations. It cannot be cornered like wheat or Stutz stock. It cannot be handled by Congress. It cannot be made a football of politics.

If there be any reader who doubts the truth of the foregoing statements let him observe what has transpired in England, where the government turned radio over to a monopoly and attempted to prevent by law the operation of receiving sets, unless a license was paid. Two hundred thousand English "pirates" are laughing at the government today and going right along listening in without licenses. The British government is up a stump.

The English monopolists have discovered, what we have contended was self-evident from the beginning: Radio IS the public. Its regulation will be governed by the public. The American Society of Composers, Authors and Publishers attempted to prevent the broadcasting of copyright music without the payment of a tax to the Society. We know of no broadcasting station that is paying such a tax. If you wish to hear copyrighted music tune in on almost any station in the country. The Society does not appear to be doing so well.

By the time the monopoly-seekers have hog-tied radio, birds will have stopped singing and sunshine will be sold to the consumer at so much per cubic yard.

—THE EDITOR.

THE GRIMES INVERSE DUPLEX CIRCUIT BACK PANEL AND LAYOUT ILLUSTRATION

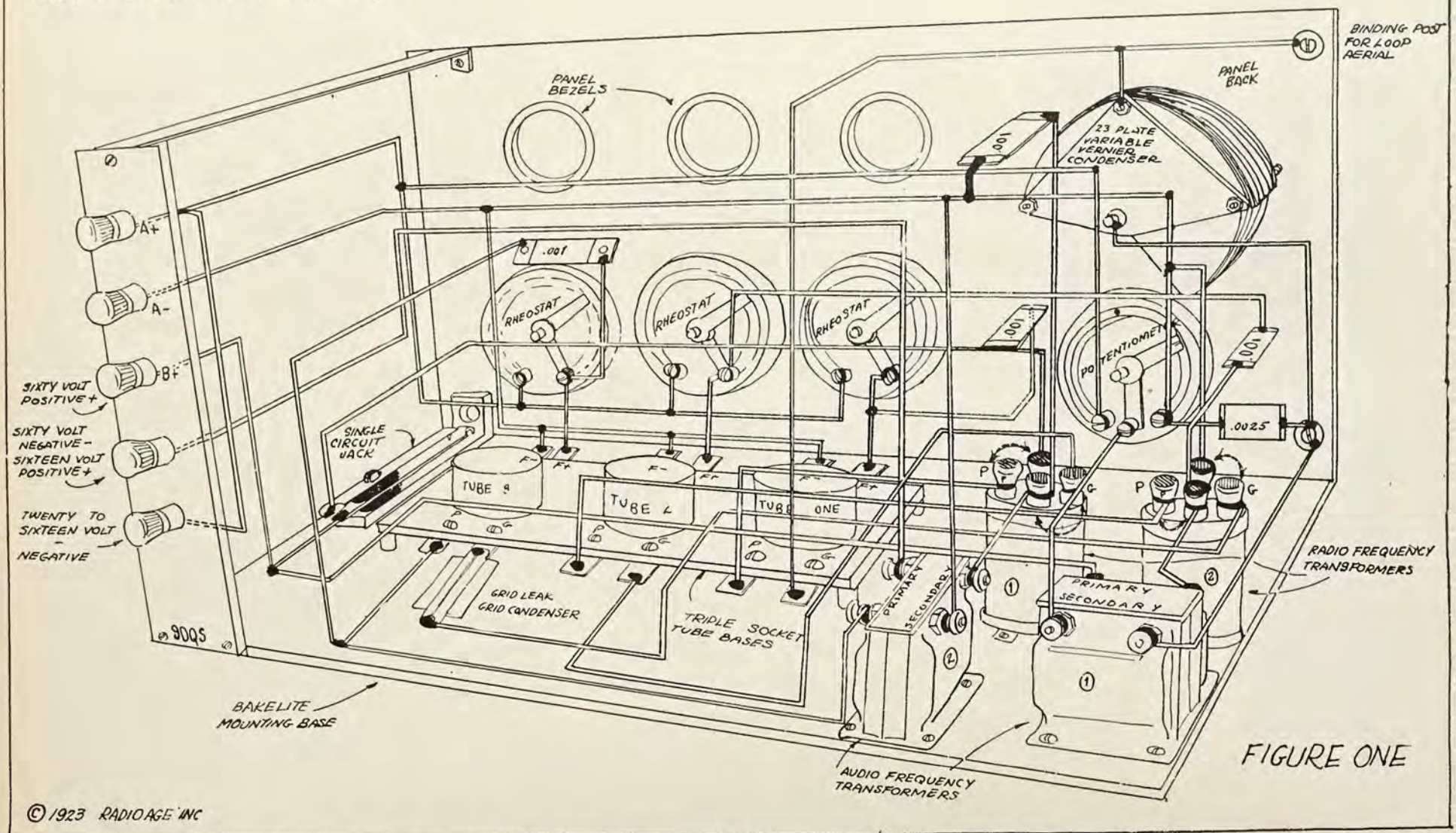

Drawing of the layout and wiring of the Grimes Inverse Duplex Circuit. The arrows on the radio frequency transformers indicate the two binding posts terminating the beginning and ends of the transformer coils.

One of the greatest troubles experienced in radio frequency or reflex work is the tendency of the tubes to oscillate and howl.

Even though radio frequency transformers are very carefully designed and constructed, they cannot be made to give the same results on one type of tube that they will give on another, consequently a particular tube must be decided upon, and the particular radio frequency transformer which works best with it, should be used. The Acme transformers were used in the set described when UV-201A amplifying tubes were used in combination with a UV-200 detector. This combination has been found to work best, while with other types of tubes, other makes of transformers seem to give better results. This does not mean that this particular type of transformer is better than the others, but merely that this arrangement gives a happy combination which works very well.

In order that the construction may proceed step by step, and a check up of the conditions may be made as the work advances, the radio frequency part of the circuit should first be connected up and tested. When this part of the circuit is wired up and found to work, then the audio frequency part may be added, but it would be useless to add the audio frequency until this part is found to function properly.

To aid the builder in this test, Figure 3 is shown. It will be noticed that the arrangement for making each tube do the same amount of work makes a circuit somewhat different from an ordinary radio frequency circuit. The upper part of Figure 3 (shown in light lines) represents the radio frequency component of the circuit. In order that it may be tested as straight radio frequency first, we must temporarily forget about the lower part of the drawing (shown in heavy lines) and make temporary connections as follows: No. 9 to No. 1, No. 2 to negative "B" battery, No. 3 and No. 6 to the 80 volt positive terminal of the "B" battery, and No. 4 to No. 5. No. 7 is connected directly to the 22½ volt terminal (positive) of the B battery, and the phones are placed between No. 7 and No. 8. These numbers are shown in the circles in the center of Figure 3.

Remember that during this test, these numbers simply represent the terminals of the wires from the radio frequency component and that none of the wires represented by the heavy lines has as yet been put into the set. When the connections have been made as described, place a UV-

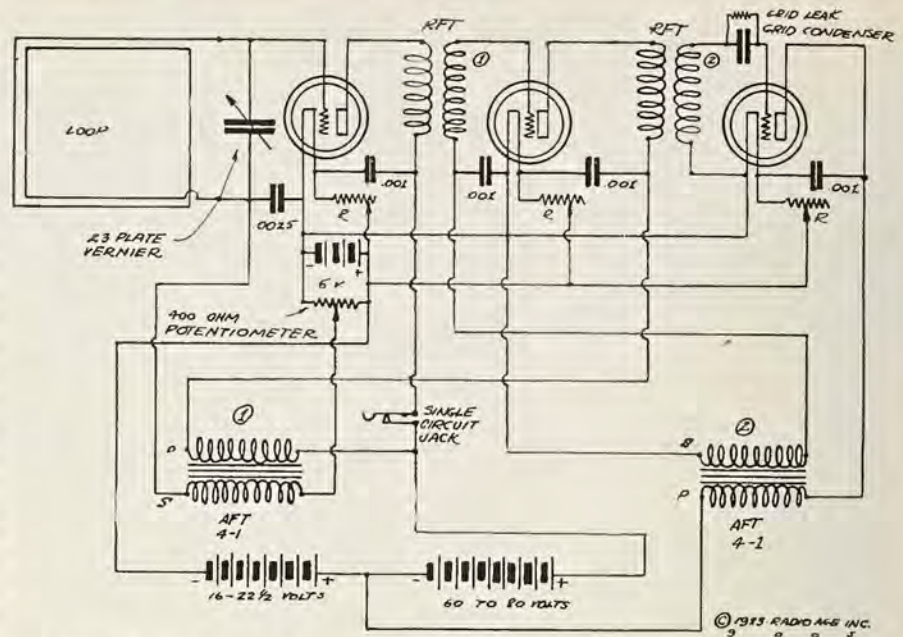

Figure 2. The finished hookup of the Grimes Circuit.

200 detector tube in the last socket (to the right of drawing) and a UV-201A in each of the other sockets. This is now an ordinary radio frequency circuit, composed of two steps of radio frequency and a detector. This should now be tried out and if signals come in well, it may be assumed that this much of the circuit is O. K.

Before making this test, or in fact, before connecting up the "B" battery, each of the .001 fixed condensers should be tested with a buzzer to prove that they are not short circuited. If no buzz is obtained then they are all right and the "B" battery may be connected. The condenser which is connected across the terminals No. 4 and No. 5 will give a buzz when tested, as this is shorted by the connection between these terminals, but all the others must test clear, or the filaments will be burned out by the B battery current getting through them.

After testing the radio frequency circuit and it is found to function, then the temporary connections are all disconnected and the audio frequency component is added. This is plainly shown in Figure 2, which is a duplicate of Figure 3 with the exception of the numbering system used for the temporary connections. In connecting up the radio frequency transformers, the terminal marked "P" should go to the plate terminal of the socket, and the terminal marked "G" must be connected to the grid of the next socket as shown. However the proper connections to the audio frequency transformers may require some experimenting as to the direction in which these

currents pass through. This merely means that the two connections on either the primary or secondary coils may have to be reversed, but they must not be changed from one coil to another.

The principal requirement in the building of this set is plenty of time and patience. Much howling and squealing will be encountered until one learns just how to adjust the set. This can usually be remedied by turning down the rheostats on the amplifying tubes, but one will soon learn just how to take care of this.

All connections must be soldered carefully, and if paste is used as a flux, it should be wiped off with a little alcohol after soldering. Most any kind of a loop will work well with the set, but to get the best results a loop 16 to 18 inches across each side is recommended. This should be wound with from 8 to 12 turns of wire, spaced about ¼ of an inch apart. Either solid or stranded wire may be used. No. 18 wire is very good, but single strand lamp cord affords a much more flexible winding. The exact number of turns must be found by experiment, but the number will be somewhere between 8 and 12. Of course the smaller the loop, the less energy it will pick up, but results have been obtained even on a 4 inch coil, such as is used for the primary winding of a variocoupler.

Send \$1 to Radio Age, 500 North Dearborn Street, Chicago, and receive this leading hook-up guide for six months. Regular subscription price, \$2.00 a year.

Hookups and How to Read Them

By Felix Anderson

Radio 9 D Q S

THERE is probably no more disconcerting incident in the career of an embryo BCL than the fact that with his initiation into the radio game he is expected to be able to understand a great many symbols, signs and diagrams. Usually, when he casually asks for information on the construction and wiring of a set, he is presented with a circuit diagram, more commonly dubbed "hookup," which to him is a meaningless lot of symbols and signs on a piece of paper, which may be about as clear as a lot of Egyptian hieroglyphics would be to the average enthusiast who has become familiar with the reading and execution of the circuit diagrams.

No doubt there would be less confusion and trouble in hooking up sets, if working drawings were used to portray different circuits. Each set is usually hooked up in an individual manner, and should error occur, there is a great deal of time and trouble expended in locating the error or incorrect connection.

A radio expert will very seldom evince much interest in the set you are using, if you show him a photograph of the layout and ask him to point out your error; but show him a concise diagram of the circuit, as you have connected it, using the correct symbols, and you will immediately notice a change in his attitude, and also the ease and quickness with which he detects faulty construction. The advantages of using a system of signs and symbols for portraying our ideas in connecting up sets and showing various circuits is readily seen.

With the idea of admitting the newcomer into the mysteries of the radio pastime, the writer has compiled a chart of symbols which are used commonly in the course of construction, correction and design of present day radio systems. It is hoped that the reader will look over them, and should the occasion arise, make use of them in his queries and suggestions.

Starting in the upper left-hand corner of the page of symbols, the conventional symbol for the antenna is shown. The symbol does not limit the size, type or kind of antenna in the least; it is merely used to designate that an antenna is used in a circuit, and its relation to other parts of the radio system. The same applies to the ground, which is



Lofty tower of the famous Station WJZ in its new home on Forty-second street, New York, between Fifth and Sixth Avenue. (U&U Foto).

represented by a heavy bar, with several lighter lines underlying.

Each symbol seems to suggest its own interpretation, much as does Indian writing. In the case of the ground, the ground symbol pictured gives the impression of the black bar being the top soil and the

underlying lines a sort of cross section of the underlying soil.

A counterpoise system is next symbolized. The counterpoise, although heretofore exclusively used for transmitting purposes, is rapidly gaining in favor with fans who find that the ground connections they are accustomed to use are inefficient and are poor conductors. It is merely another antenna system, similar to the one used as the receptor, connected to the set in lieu of the ground.

The symbol of the loop antenna is next shown. Connections are made to the free ends of the wires as indicated in the illustration.

Referring to the illustration of the two-slide tuning coil, it is easily explained that a coil of wire is usually indicated in a diagram by the use of a series of loops in a continuous string. This coil is also called an inductance. The two arrows indicate that there are two sliding or similar arrangements, which provide a means for increasing or decreasing the number of turns used in the circuit. This variation can be accomplished either by the use of sliders or taps. Sometimes a tapped inductance is indicated as in the symbol for the tapped coil. The type of circuit, and the design of the set govern the use of either taps or sliders.

Connections of wires and instruments are usually indicated by a dot, and the non-connection where lines cross each other in a circuit diagram is indicated by a small hump, inferring that the wire is jumped and not joined. Binding posts where designated are indicated by a small circle.

Batteries, of all voltages and types, are usually shown by the use of a long light line, followed by a shorter, heavier line, running immediately parallel to each other. The long line should be marked plus or positive, while the shorter, heavier line is termed the minus or negative.

A choke coil, commonly used by the average enthusiast, is designated by a series of parallel lines, encircled by a series of lines indicating the wire, the parallel lines showing that a core of soft iron was used, around which the wire is wound.

The variocoupler or loose coupler is probably one of the most widely used and most popular forms of tun-

ing systems now in use. Its presence in a circuit is shown by the symbol consisting of two spiral lines parallel to each other, the one in this case to the right being the primary and the other the secondary. In the illustration provision is made for two methods of varying the amount of wire in use, the proper connections for this being shown under variocoupler connections. If a coupler is used having more than seven taps, it is customary to provide two sets of switch taps, connecting them as shown. However, if there are only seven or less taps on the outer coil, they are connected by using only one switch, and taking the beginning wire, or top wire, and connecting it to the antenna, the rest going to switch-points, and the switch going to the ground.

A variometer consists of two coils of wire connected in series as shown and is indicated in the circuit by a similar sign. Honeycomb coils being nothing more than a coil of wire, or inductance, are indicated by the usual sign for an inductance as in B. Sometimes they are shown in circuits by the symbol A.

Resistances in circuits are practically always indicated by a jagged line, showing that that particular instrument is noninductive: i. e., does not transfer any energy to another part of the circuit by the induction phenomena.

A small, blunt-headed arrow, and sometimes a thin, curled line, is used to portray the crystal detector, as shown in the chart. Meters, whether volt, galvanometer, ammeter or milliameters, are indicated by a circle, as shown. The lines on either side indicate the connecting wires.

The grid leak, as shown, is a form of resistance, a very high one, indeed, and its unit of measure is usually called a Megohm. This term means one million ohms. Its construction is described elsewhere in this issue.

Condensers, one of the most important instruments in radio, are indicated by two heavy parallel lines as shown. An arrow drawn through its center conveys the idea that it is variable. Audio frequency condensers are indicated somewhat differently. A condenser, it is understood, consists of two parallel conducting mediums, separated by a dielectric substance. The insulating material may be air, glass, mica or oil.

Transformers, being inductances, are indicated by the conventional symbol. In this case the radio frequency transformer, having no iron core, has no lines separating the

coils. Connections on these transformers are usually marked G for grid, P for plate, B or plus (+) for the B battery, and F or minus (-) for the negative filament.

Jacks are indicated as shown, A being a two-circuit jack, while B is a single-circuit jack. They are used to plug in the headsets on detector, and first stages of multistage amplifiers, and are also used to change from phones to loud speaker. The plug when inserted to the jack pushes up the two springs, permitting the current to flow through the phones only, and opening the circuit for the remaining instruments.

The tube, its socket and its various circuits are next shown, in order that the reader may become familiar with its terms. G means the zigzag wire inside of the tube, F and F the filament from where the electrons, the secret of the vacuum tube, are emitted, and P the plate.

It should be remembered that nearly always a positive charge is sustained on the plate of the tube, as this is the base of its operation.

For the benefit of those who are not familiar with radio terms, an oscillatory circuit is shown, which consists of a condenser and inductance in series. There is also always present another unit in this circuit, resistance, which may be in the connecting wires, in the condenser or in the inductance.

Practically, the entire radio game is governed by the use of the so-called hookup, and an example is shown at the bottom of the chart. Due to the particular arrangement of the apparatus, this circuit is called the Armstrong regenerative circuit, deriving its name from its inventor, Major Armstrong. Because it has three permutations for tuning, it is sometimes called the three-circuit tuner.

Referring to the diagram, we notice that the antenna is connected to the primary or outer coil of the variocoupler through the switch and the taps, and also to the ground by another set of similar taps. It is through this coil the received impulses travel, and in the course of their travel are transferred to the secondary by induction. The set is tuned to their frequency by means of the variocoupler, and still further tuned by the use of the variometer as shown, in the "grid" circuit. Passing through the grid condenser, they are impressed on the grid of the tube, and produce a change in the plate voltage: the variation, being general, is detected in the telephone receivers placed in the plate circuit. A variometer placed in the plate circuit, enables us to make very weak sig-

nals audible, due to the fact that by its adjustment in relation to the rest of the circuit, a delicate balance can be effected.

The lines connecting the various symbols indicate the method used in wiring up the apparatus. The circuit diagram does not mean the apparatus must be arranged; it merely shows how these several instruments should be electrically joined.

It is hoped that many of our BCL (broadcast listener) friends may benefit by this chart, and may be more intelligently enabled to read and study diagrams as they appear in the course of their radio experiences.

Automatic Transmission and Reception

During the last ten years, commercial companies developed automatic printing telegraph equipment for the transmission overland wires of typewritten characters from one point to another. The present means of copying signals with the tape requires the employment of two or three extra men for translating purposes. Due to the reduction in operating personnel in the Naval Service, it became imperative to devise means to operate stations with reduced personnel. Experiments conducted in 1922 prove conclusively that automatic printing equipment could be applied to radio as well as to land wire. So much faith was placed in this new method of transmission and reception that automatic recording telegraph equipment has been installed in Naval high power circuits at San Diego, and Washington.

Ireland Gets WGY

That members of the Irish Constabulary are not always engaged in offensive or defensive operations with the Revolutionists is indicated by a letter recently received by WGY, the Schenectady station of the General Electric Company, from Harold Johnston Special Constable 11038, Ulster Special Constabulary of Barons-Court County Tyrone.

Constable Johnston wrote that he picked up WGY, February 24. "Your music was very loud and exceedingly clear," wrote Mr. Johnston, "especially the Radio Quartet and last of all the bells could be heard with phones one foot from ears. We are using a five valve receiver."

Invalids Like It

A letter signed "Patients of the Vermont Sanatorium," was recently received by WGY, acknowledging the pleasure and entertainment they get from the radio programs. The patients, sixty in number, are suffering from incipient tuberculosis and most of them depend upon WGY for the Sunday religious services. They wrote that they get the 7:45 p. m. concert but have to be tucked into bed at 8:30.

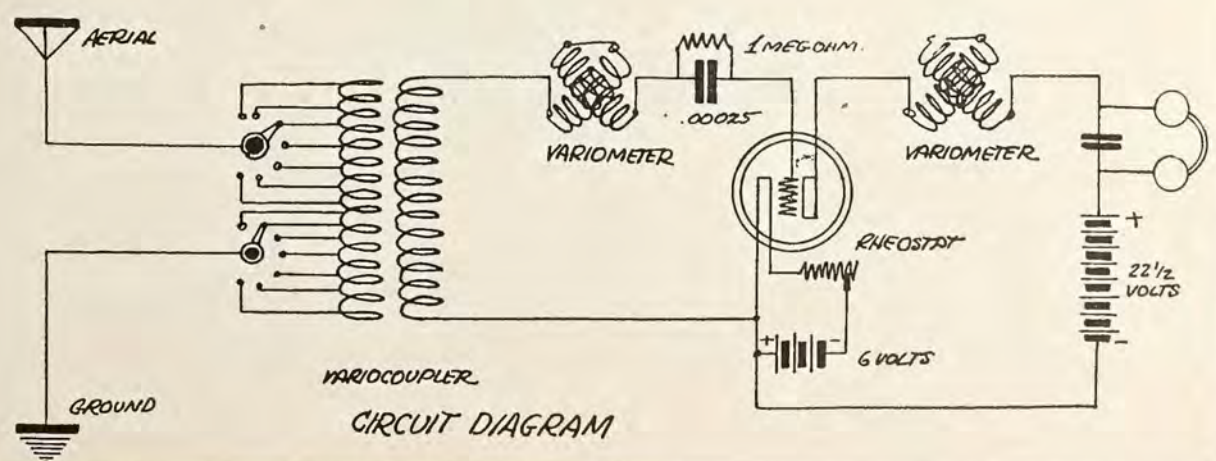
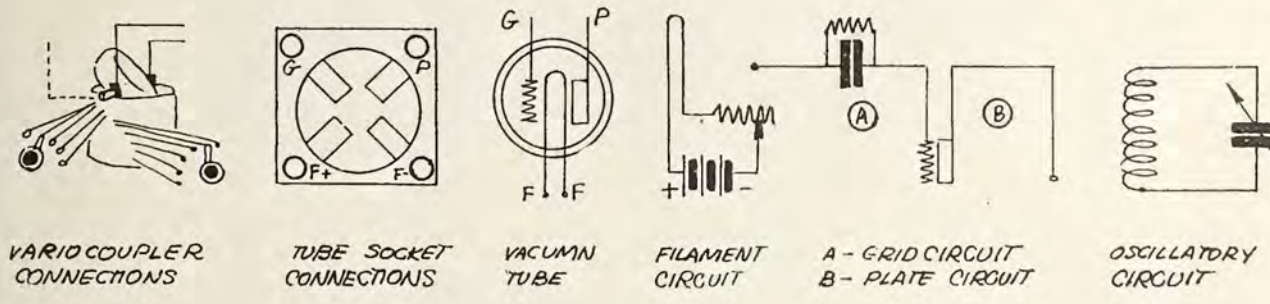
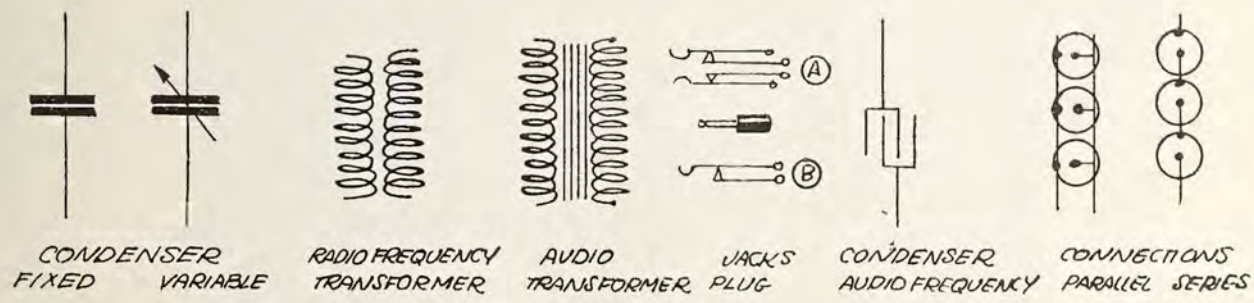
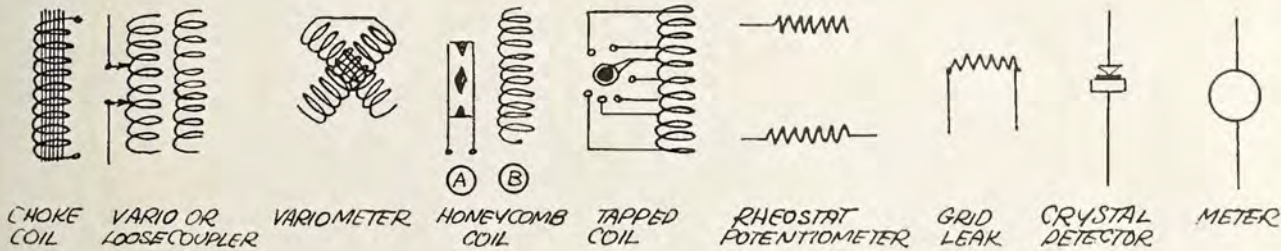
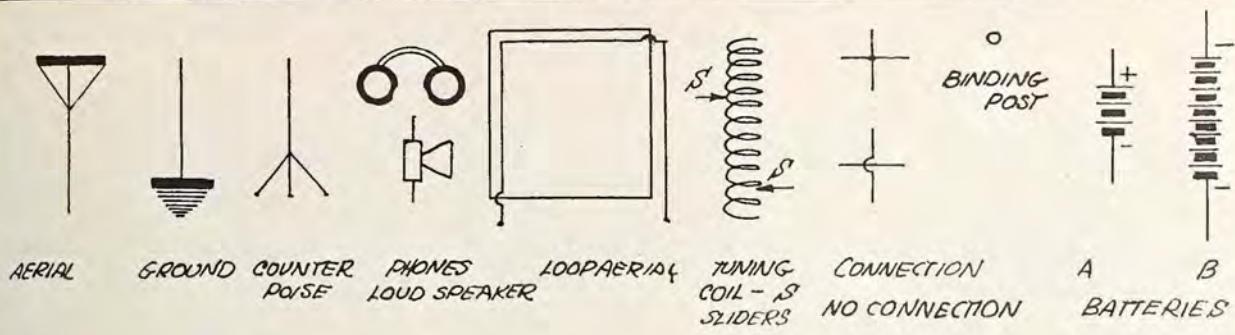

Proper Antenna for Tuning

By F. CONRAD

Assistant Chief Engineer, Westinghouse Electric & Manufacturing Company

THE ability to hear a desired station alone, or "selectivity" as it is called, depends in part on the receiving apparatus and in part on the antenna system to which it is connected. Many believe that the better the antenna, the better the signals. This is true, but it does not necessarily mean that the best antenna is the largest. The function of the antenna is to transfer to the receiving apparatus the electric forces which are set up by the waves being transmitted through space. This receiving apparatus must discriminate between the electric forces due to the radio wave it is desired to receive, and the forces due to the undesired waves, among which are the waves from "Dame Nature" herself, or "static" as they are called.

The selective receiver is one that offers a high resistance to the flow of current which would be set up by the electric forces from undesired waves, and offers a low resistance path for the flow of current due to the electric forces from the waves it is desired to receive. In other words, it permits you to hear the stations you wish to hear, and to tune out those you do not wish to hear.

The receptive ability of an antenna is, in general, determined by the height of its horizontal portion above the ground, or, stated differently, the strength of the electric forces induced in an antenna by the radio waves is proportional to the height of this antenna. Therefore, to tune out or discriminate between different waves, the selectivity or resisting power of the receiver to interfering waves would have to be increased as the antenna height is increased, while to receive an equal signal from a desired wave, the re-

sistance in the receiving set to this desired wave, would have to be decreased as the antenna height is decreased.

Experiments have shown that when the antenna height is increased and a receiver, such as a crystal-detector set or a tube set not using regeneration, is used, the signal at first increases but soon reaches a maximum strength, which can not be exceeded by further increase of antenna height. This height is such

However, as the same resistance will be maintained by this receiver against undesired waves the reduction of height will therefore give a greater selectivity. Of course, in general practice it usually will not be possible to obtain quite the same strength of signal with the low as with the high antenna, as there is a certain amount of absorption or loss near the ground which tends to reduce the possible signal strength.

Should the location be such that the antenna is perfectly clear and free from surrounding objects, the low one will be found to be practically equal to the high one, when a regenerative receiver is used. But should the antenna be located where it is considerably shielded, as where it is surrounded by high buildings, it is possible that the signal strength will be greatly influenced by height. In this latter condition, it will probably be necessary to make up for the poor selectivity of the high antenna by using

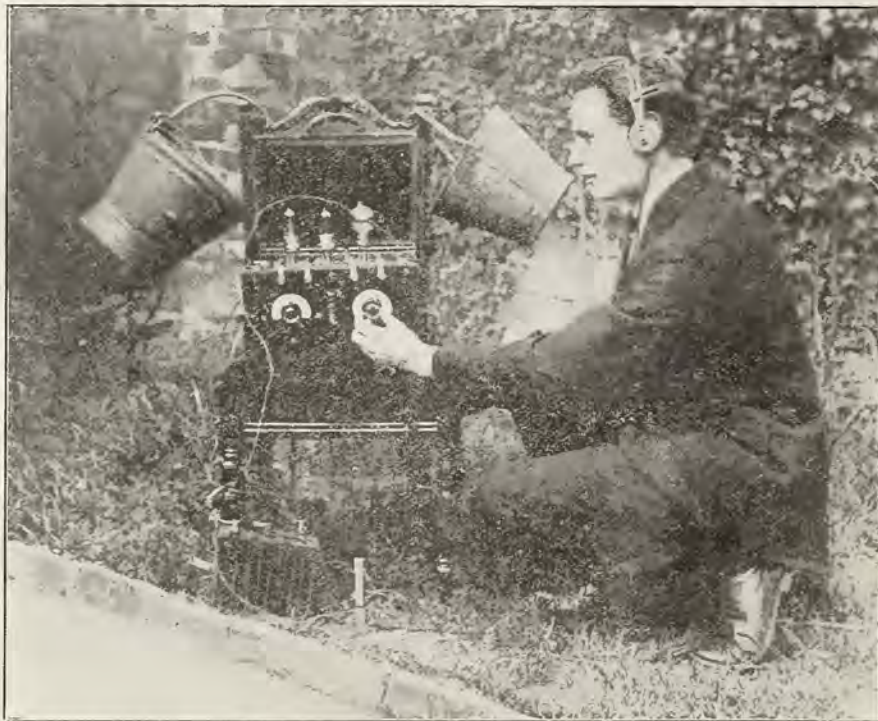

This fan, snapped in his garden in Sheffield, England, uses two tin pails as aerial and counterpoise. He easily picks up London and Manchester. (U&U Foto).

that the electric forces set up by the incoming wave is sufficient to drive through the receiving apparatus the full current strength which is equivalent to the received signals. To express it in another way, this maximum current is that which would itself set up the same strength of radio wave around the receiving antenna as is induced by the transmitting antenna sending out the signals it is desired to hear.

A vacuum-tube receiving set, in which the principle of regeneration is employed, tends to reduce the resistance to the flow of current from a wave corresponding to that for which it is tuned. Therefore, if a regenerative receiver is used, it will be found possible to maintain the maximum strength of signal, even with a reduced antenna height.

a somewhat elaborate receiving apparatus. Under the conditions surrounding the average residence district, it usually is possible, with care in the location of the antenna, to maintain good signals, even though the height is considerably less than with the scheme generally employed of attaching the horizontal wire to some point near or on the roof of a two-story house.

The actual selectivity required divides itself into two classes or conditions of service; one in which it is desired to discriminate between two relatively nearby stations of approximately equal signal strength but separated by some interval of wave length, the other where it is desired to discriminate against a nearby station and receive from a

(Continued on page 23.)

The Passing of an Old Friend

"W. J. Z. Signing off—Good Night"

By FLOYD JACQUET



YOU heard the familiar voice of the announcer say: "This is Station WJZ", as you have heard it many, many times before.

You may have detected a slight trembling, an undercurrent of emotion in the usually calm and even voice of AHN when he made this statement for the last time at the conclusion of the broadcast on Monday evening, May 14th.

"What" you said, "is WJZ, the first station I heard, going to close down? Aren't we going to hear our old friend's voice any more?"

The fact that the original WJZ, the one whose voice endeared itself to thousands of radio enthusiasts throughout the country, on that night spoke for the last time to its countless friends, North, South, East and West in many lands.

It was a simple event, this farewell of the old WJZ. There was no impressive ceremony, no occasion for speech making. WJZ passed out of the broadcasting firmament as simply as it entered it, quickly, and with dignity.

There were radio fans who swore by WJZ. It was the first station that many of us ever heard, our ABC in radio broadcasting.

WJZ led the field for one and a half years. This is a long period for a broadcasting station, and in that period many stations have been built and operated. When WJZ began its first famous broadcast on October 12, 1921, there were only three or four stations broadcasting throughout the land. Today, there are about 600, but in spite of this immense increase, WJZ has held its own, and in many ways, has led the way.



The leading characters in WJZ's history: (1) G. W. Horn who made the first broadcast from WJZ at Newark; (2) H. E. Miller who developed WJZ's staff; (3) George Blizotis chief operator; and (4) William H. Easton, director of WJZ, who delivered the farewell address.

Day in and day out, faithfully, WJZ's kindly voice was at the beck and call of the knobs of your receiving instrument. It never failed you once. You turned it in and there it was. It entertained, charmed, or cheered you.

WJZ's sterling record was not a matter of luck. It required superhuman effort at times to uphold its past performance, and untiring efforts to provide the largest audience of any station with a peerless program.

Who were the men behind the scenes at WJZ, the personalities whose work went on, unknown to the audience, and who labored to make WJZ the better station at all times?

When it was decided in October 1921 to place WJZ in operation, there was no organization, no staff, no announcers, no artists. There was only a station, on top of the large plant of the Westinghouse Electric and Manufacturing Company, in Newark, N. J. As you go by on the Lackawanna Railroad, you can see the two high masts, supporting the antenna system. The first WJZ aerial was not as high, nor as pretentious. Neither was the station itself, located in a radio room specially built on the roof.

A radio staff was developed under the master hand of H. E. Miller, Superintendent of the Westinghouse Newark Works. Mr. Miller picked out from among the radio personnel of the Company, men who knew their jobs. Employees were tested out to find men with suitable radio voices to be trained as announcers. The entire radio personnel was Westinghouse, and went to work in the typical Westinghouse pioneer way.

In the first days of broadcasting, the operation of the station was rather difficult, the public was a bit skeptical, but interested. It was quick to applaud the efforts made, and to appreciate the superior programs.

But the work was tedious. Great credit is due to Mr. Miller and members of his staff who listened in night after night, checking up on the broadcasting, the modulation, and finally on the program.

The securing of good, pleasant and entertaining programs was no small task. This work as well as the general managing of the station developed upon Mr. William H. Easton. It was found that one of the most difficult things to do in the early days of commercial broadcasting was to interest newspapers in this new field. Untiring efforts on the part of Mr. Easton secured the recognition of radio broadcasting and awoke the duties of newspapers toward the hundreds of new fans.

WJZ enjoyed the distinction of being the first broadcasting station to have its complete program published by a Metropolitan newspaper. Over eleven hundred newspapers in the United States and foreign countries published the WJZ program. Much of this work was carried out by Mr. P. A. Sensenig.

In addition, WJZ has been the subject of many magazine articles and it has appeared on the screen. Dignitaries and men prominent in engineering circles have come from foreign lands to visit the station.

From a point of equipment, WJZ was rated as one of the most powerful broadcasting stations in operation in the country. Its original transmitter was of 500 watt power.

Last November, the power of the station was doubled, and WJZ could claim a transmitting radius of 2,000 miles. As a matter of fact, WJZ had the most consistent transmitting record of any broadcasting station. It was heard almost nightly in California and in England. It had followers in Australia, Cuba, South America and Europe. On one occasion, its signals were heard simultaneously in Honolulu and Bremen-haven, Germany, some 10,000 miles!

To keep a station such a time as this required the best of operators and the most competent care. Six licensed radio operators, all of them having had extensive practical experience either on land or sea or both, stood the practically continuous watch at the instruments. The Chief Operator, Mr. George Bliziotis was in direct charge of this work, and many times the proper operation of WJZ depended upon his quick, prompt and skillful handling of the situation.

The first man to ever broadcast station WJZ was Mr. C. W. Horn, when the station was officially opened up in October 12, 1921. Mr. Horn is now Superintendent of Communications for the Westinghouse Electric & Manufacturing Company. It is his duty to see that the other Westinghouse stations, KDKA, in Pittsburgh, KWY, in Chicago, and WBZ in Springfield are kept in the pink of conditions. That he has done his work well is shown by the fact that these stations are without rivals as far as range, consistent transmission and modulation are concerned.

Station WJZ was a pioneer in many ways. It originated many new variations in an attempt to put out a really interesting program.

Woman Is Boss



Station WDT has been reopened in its new home at 510 West 23rd Street, New York, in the studios of the Premier Grand Piano Corporation. The station is in charge of Miss Vaughn De Leath, the "original radio girl." The programs announced by the station are of outstanding merit.

For instance the method of identifying operators and announcers was introduced at WJZ, and the practice soon extended to every broadcasting station worthy of the name. The voices of AWN, (Mr. J. L. Watt); ACN, (Mr. T. Cowan); AJN, (Mr. M. J. Cross), all announcers, and OBN, (Chief Operator G. Bliziotis) and OHN, (Operator Hiller) are well known to thousands of radio fans. Some of them reflect truly the personality of the Station, and have made many friends for themselves over the radio.

The first time radio fans adjusted their watches was through the re-broadcasted NAA (Arlington) time signals from WJZ. This little innovation in the radio program was immediately popular, and spread out to many other stations.

And then, one afternoon radio fans who could not attend the World Series were startled to pick up the cheering of the crowds at the Polo Grounds and of receiving announcements of the plays, on their receiving sets. WJZ was broadcasting the baseball game reports. This was the first time that remote radio broadcasting was ever attempted in the Metropolitan district.

Subsequently, the first church service and then the first complete grand opera were sent out via WJZ's powerful installation.

But WJZ's entertainment was not for grown-ups alone. For the kiddies, bed time stories were told by children story tellers and authors of national repute. Sleepy ears heard many tales of Jack Rabbit, Bunny Briar and others from Thornton Burgess, David Cory, Florence Smith Vincent and Howard Garis.

The popularity of WJZ spread very quickly. The most prominent artists,

public men and entertainers came to WJZ to broadcast. On the guest book of the WJZ studio and reception room may be found the names of Mary Sundelius, May Peterson, Cecil Arden, Frieda Hempel, Lydia Lipkowska, Vice President Coolidge, Premier Clemenceau, Lord Robert Cecil, Governors and Senators of many states, prominent lecturers and artists too numerous to mention.

WJZ's scope was international. Its waves radiated into parts unknown, and were heard throughout the civilized world. WJZ was the first station to be heard in England, and reception is being achieved daily in London. The programs of English stations are being modeled after WJZ's programs, because of their completeness and entertaining value.

But the old WJZ is shut down. It has found a more modern home in the Aeolian Hall Building, at 42d Street and Fifth Avenue in the heart of the city. Here a super-station has been erected by the Radio Corporation Engineers who were always interested in the development of WJZ. Mr. C. B. Popenoe went from the old WJZ to the new to manage its programs and its activities.

It may put on a new voice, be clothed in a new glory, but to many, old WJZ will be just "WJZ" an old faithful friend, whose presence we feel, and whose voice we love.

Monday night, right after the broadcast, the operator in charge made an entry in the station log book, as he has done every night for the last year and a half. This entry differed from all others, because it read:

"WJZ signed off for the last time. Station closed down—All's well."

Fake Inspectors

A "fake" radio inspector has been issuing "licenses" to amateur and broadcasting stations in Minnesota, the Department of Commerce has been advised. Using the return stub of an amateur application blank secured from the Department, an individual giving his name as Cecil Osborne is said to have supervised the installation of a radio station in Minnesota, and issued what he called a license.

This imposter claimed that he was a former radio operator of the Navy Department and a member of the Naval Reserve. The only record of a man of that name in the files of the Navy Department is that of a deserter who served for a time as an apprentice and seaman. He deserted in San Francisco in July, 1922, the official records state.

All radio inspectors of the Department, the officials in Washington point out, are supplied with means of identification, including official badges and identification cards bearing their photographs. Amateurs and broadcasters are advised to ask for identification cards and to pay no fees for licenses. Although the White Radio bill contemplated the payment of fees for licenses, it failed to pass; the present law provides for the licensing without charge.

W J A Z, a Station With a Difference

THERE is something about a great broadcasting station that suggests a combination of the pilot's cabin on a giant ocean liner and the foyer of a theater. There are instruments in the operating room that give an awesome impression of easy mastery over vast distances. A visit to the transmitting plant, always at some distance from the operator, gives one the same thrill that he experiences when looking at the equip-

to communicate with MacMillan while he is on the Arctic expedition, sending to him not only the events of interest, but also communications from the families of himself and his crew.

The Crystal Studio is surrounded with three-ply, sound-proof, glass partitions. In the past, artists waiting to broadcast have been annoyed by two factors: First, the presence of microphones, and second, the absence of an audience. To

steel buildings on any side. The steel towers extend 175 feet into the air. The antenna is of the fan type with cage lead-in. An entirely new system of modulation is used in this station, which system will be disclosed as soon as patents, for which application has been made, are granted. Under the WJAZ system, there is no need of the artists being close to the microphones. As a matter of fact, in many instances, they

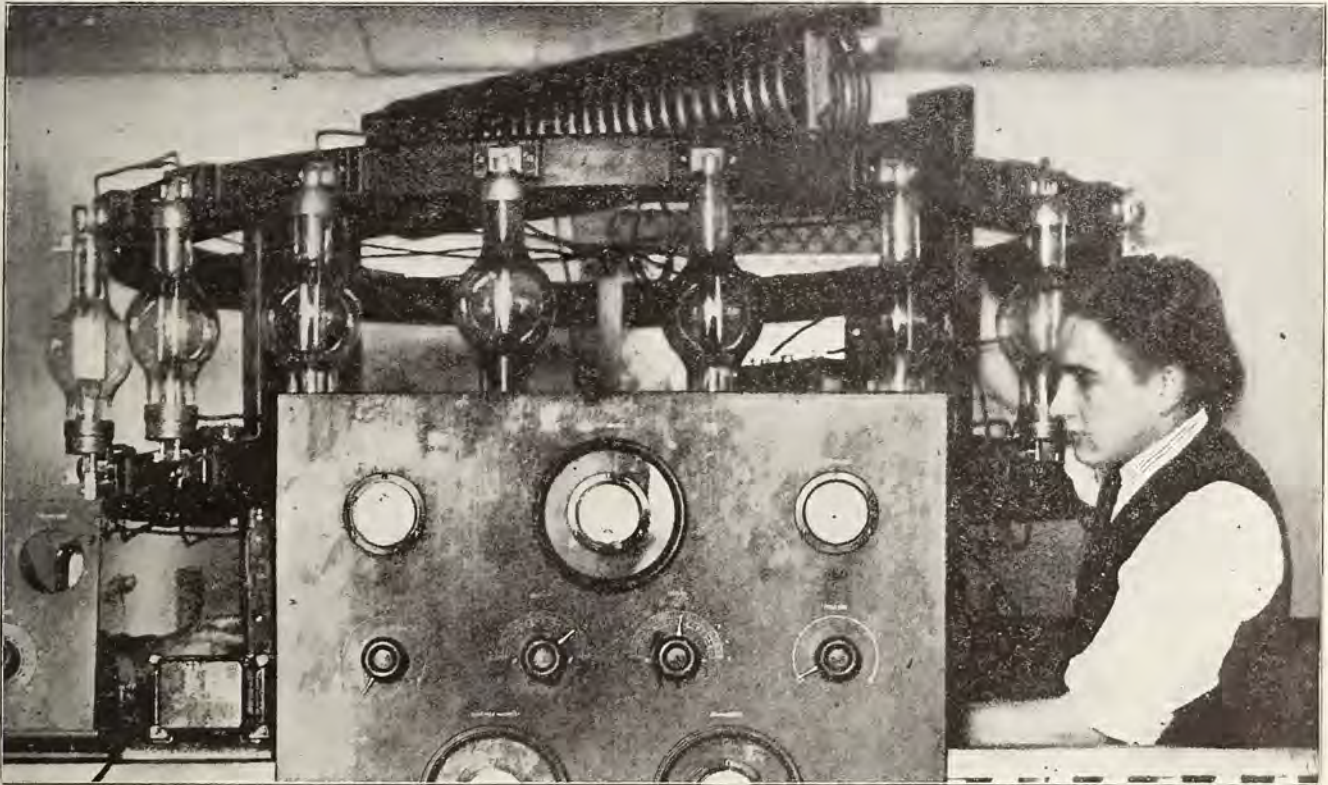

Giant transmitter at Station WJAZ, Chicago, showing the arrangement of big tubes in a circle. The studio of this station is enclosed in plate glass. (U&U Foto).

ment of an electric power station. With this difference, however, that the tubes and coils and wires here visible, all appearing to be alive with terrific, though pent up power, really do nothing more than to start thousands of electromagnetic waves off on a journey that takes them at a speed so great that they could circumnavigate the earth about seven and one-half times a second.

The new Zenith-Edgewater Beach station, WJAZ, is such a station. WJAZ is not only a leading Chicago station, but it appears to be a bidder for national popularity.

The station is powered by a ten kilowatt, 4,000 volt generator with a duplicate generator in reserve. On the opening night using only one-third of our power, it reached Oregon, California, Florida, Nova Scotia. It received 1,800 letters the Monday following the Saturday opening. It is now operating on a little more than half power and will probably not turn on full power until it starts talking with MacMillan on his North Pole trip. This station is to be used

overcome both of these difficulties, the microphones are carefully concealed and are not visible to the operators from any angle; as a matter of fact, they are concealed in the floor lamps in various parts of the Crystal Studio. The artists always have an audience to which they are singing, this audience being on the opposite side of the sound-proof, plate glass partition. Now, the audience can see the artists singing or playing, but cannot hear them. However, there is a small receiving set just outside the plate glass partition, so that the audience by radio hear the artists as they are performing.

The operator sits in a small, triangular, plate glass room and has full view of all the artists in the studio and the orchestra playing in the Marine diningroom. The entire performance of artists from the Crystal Studio is visible on the east from the Beach promenade, on the north from the hotel terrace, on the west from the Colonial diningroom and on the south from the Marine diningroom.

The generators and the antenna are located 300 yards north of the Crystal Studio, right on the lake shore, with no

are fully ten yards from the microphones, the volume being controlled entirely by the operator in the triangular glass operating room. The artists performing have every convenience of the artist on the stage, except one, and that is that they can only see the applause of their audience, but another microphone and a loud speaker are being added so that the applause of the audience will be transmitted through the sound-proof plate glass and will be audible in the Crystal Studio where the artist is performing.

Now as to the policy of the station. No talkers, whatsoever, are permitted, for the time being, at least. The program is entirely a musical entertainment, starting at 10:00 p. m., Chicago daylight savings time, and running until 2:00 a. m. on Tuesdays, Wednesdays, Thursdays, Fridays and Saturdays, 5:00 to 8:00 p. m. Chicago daylight savings time on Sundays. The highest type of classical music with excellent artists from the Crystal Studio alternate with dance music every second number from the orchestra in the Marine diningroom.

THOUGHT WAVES FROM THE EDITORIAL TOWER

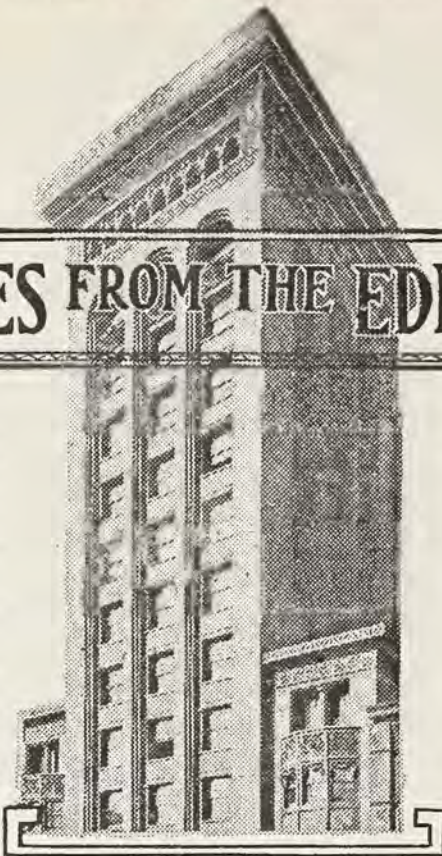

THE question, asked by millions in the last year, as to whether radio is a passing craze, has been answered. Gross sales of radio merchandise for the year ending May, 1923, were \$100,000,000; double the total gross of the preceding year. You cannot laugh off that kind of showing.

Many other interesting figures about the growth of radio are contained in a survey published by the American Radio Journal. One item in the table shows that the number of manufacturers of radio sets and accessories decreased from 3,000 to 1,000. This is an apparent setback but actually it means that the industry has eliminated the fly-by-nighters. This pleases the fans. They want dependable equipment. The manufacturers themselves are benefited because the trade is being stabilized.

The America Radio Journal publishes the following figures:

	May, 1922	May, 1923
Dealers.....	\$ 4,000	\$ 6,000
Mfg. companies.....	3,000	1,000
Jobbers.....	1,000	3,000
Annual gross sales.....	\$50,000,000	\$100,000,000
Failures.....	500	5,000
Sets sold.....	100,000	300,000
Tubes sold.....	150,000	500,000
Values parts sold.....	\$35,000,000	\$70,000,000
Employed in trade.....	25,000	40,000
Mail order sales.....	\$ 3,000,000	\$ 4,000,000
Credit losses.....	250,000	3,000,000
Export gross value.....	100,000	1,000,000
Import gross value.....	250,000	3,000,000
Trade advertising.....	1,500,000	10,000,000
Broadcasters.....	250	600
Radio fans.....	500,000	2,000,000
Dealers' inventories.....	2,000,000	15,000,000
Newspaper depts.....	10	600
Radio publications.....	15	30

Predictions for the future are made by the same publication:

"The future seasons of radio have every promise of being even more phenomenal than that which has just passed," observes the editor of the publication. "With higher powered broadcasting, more efficient receiving sets, better circuits, better technical education, etc., the public is making radio bowl along faster than most of the trade appreciate.

"Sociologically, radio has already begun to change the habits and manner of living of millions. Its effects are no more to be stayed than the powers of a tornado let loose.

"We can predict safely that during the coming season, which really begins with May 1, that improved types of apparatus will mean a heavy resale market to old customers. What if \$100,000,000 of merchandise was sold last year? Over \$30,000,000 of it is replaceable. Tubes, batteries, panels, parts—almost any piece of radio has its deterioration loss.

"The traffic in 'seconds' is enormous and will increase. Yet every one is satisfied to buy more and more if he can improve distance, audibility, selectivity, etc. The field is fathomless. There is practically no 'absorption point' and as for the 'curve,' it will be straight up for at least five years to come—more so if broadcasting receives the proper support."

TECHNICAL experts are arguing whether or not, under the Arms agreement, the gun elevations of the American first line battleships may or may not be increased, when what we really need is radio and airplanes. In order to increase the range from around 21,000 yards to 24,000 yards, several degrees of elevation would be necessary, but with this increase neither the gun pointers nor the look-outs on the masthead could see where the shells fell. Airplanes with radio transmitters are the only means whereby battleships can fire with any degree of accuracy over 22,000 yards or

about eleven nautical miles. Radio-equipped airplanes are also of great service under that range, especially in the case of a smoke screen, which would make a target invisible from the ship itself.

Due to the curvature of the earth, a rangefinder in a fighting top, about a hundred feet above the surface of the sea, can see the water line or horizon approximately no further than eleven miles distant, which is the resulting limit of accurate fire if he does his own spotting. That is, if the observers endeavor to tell the gun captains below how much short or over the target their shots fall or how far to the right or left, eleven miles is the maximum range.

For fighting top observations over this range much taller masts would be needed or airplanes which can spot by radio. To see the water line at 30,000 yards a fighting top would have to be 170 feet aloft—too high for practical purposes by many feet. Of course, a masthead lookout a hundred feet above the sea could see the mast and perhaps the superstructure of a ship over the horizon, but he could not see the fall of the shells in the water or their splash, and would only be able to tell if the mast or superstructure were hit, which would not aid the gun pointers in picking up the target.

It is for this reason that airplane spotters which can ascend several thousand feet, are used in the Navy and it is only by radio that they can report to the gunners the exact spots where the shells fall, thus enabling them to correct their aim.

What we need as much as gun elevating is more naval air spotters radio-equipped.

Loftiest Antenna

Towers of the new WMAQ station, on the roof of the Hotel LaSalle, will be twenty-two stories above the level of Madison Street. The antenna will be the loftiest in Chicago.



A memorial tablet recently was unveiled in Calvary Episcopal Church, Pittsburgh. The tablet was dedicated to the invisible congregation which for two years has been listening to church services broadcast from Calvary Episcopal through Westinghouse Station KDKA. The picture shows The Rev. Edwin J. van Etten, pastor, and H. P. Davis, vice president of the Westinghouse Company. The choir boys who have added so much to the radio services, are also shown.

Evangelism by Radio

That the broadcasting of religious services has increased church attendance; that radio has been a real help to the work of the church and has brought satisfaction and comfort to hundreds and thousands of people, is the opinion of the ministers of Schenectady who have been cooperating with M. P. Rice, director of broadcasting of the General Electric Company, in the transmission of church services.

From the inauguration of the radio church service by WGY, October 1, 1922, the studio management has cooperated very closely with the Ministerial Association, of Schenectady, N. Y. The Ministerial Association, which is made up of the pastors of all the evangelical churches, named a committee of which the Rev. Robert W. Anthony, pastor of the first Presbyterian Church, is the head, to assist the studio manager in the assignment of clergymen for the vesper services and in planning the order in which the services of different denominations should be broadcast.

In nearly every case the morning and evening services of a church are broadcast. The church is connected to the transmitting equipment of the broadcasting station by means of land wires. Two microphones are placed in the church, one for the preacher and another for choir and organ. But for the presence of the microphones, the church congregation would not be aware that the service, ordinarily limited to the four walls of the church, was going out into thousands of homes over a great territory.

Summarizing the first six months of broadcasting of religious services, Rev. Mr. Anthony made the following report:

"The first services were held on Sunday, October 1, when the morning service of the First Methodist Church and a vesper service from the studio were broadcast, and services have been broadcast regularly from that date. Recently, an evening service has been added to

the program. On Thanksgiving day, the union service of the First Presbyterian and First Reformed Churches was sent out through WGY. New Year's eve came on Sunday evening, so a special Community Watch-Night service, commencing at 9 p. m. was arranged at the First Methodist Church and sent out through the station. A community three-hours service from 12 to 3 p. m. is to be broadcast Good Friday.

"As far as possible, each church equipped with an organ and good musical leadership has taken its turn. The ministers whose churches are not equipped with pipe organs have as a rule had charge of the vesper service. Occasionally, out-of-town churches have been invited to send out their services.

"At once, the participating ministers began to receive letters of appreciation, telephone calls, and words of gratitude from members of their congregation or acquaintances whom they met in the city. This made it possible to visualize the radio congregation. A large number of those listening in are aged and shut-in; some of them are partially deaf, others are blind, still others are helpless cripples. One patient sufferer for thirteen years, recently said that Sunday had been the longest day in the week until the broadcasting of religious services began, and now it is the best and brightest day in the week for her. Deaf people, who have not been able to hear the ordinary church service, can hear distinctly the service by radio. Mothers with little children who, on that account, are unable to go out to church, have been made happy by listening to the religious services. The gratitude and joy of people of this sort has been a revelation to the ministers who have participated. People who have not gone to church for years are listening with the keenest interest and with growing friendliness toward the church. Many of these send either through the mail or by some friend, a

small offering to the church whose service they have heard. People in the country, unable to leave their farms, have thoroughly appreciated the broadcasting of religious services.

Homer Rodeheaver's famous chorus, and his own voice leading congregational singing, may become available to churches throughout the United States as the result of radio records now being made in Chicago.

Not only will the sacred services be within reach of the churches, but private homes in the city or the remotest parts of the country may tune in for the very highest type of religious service, as it is offered in the wealthiest congregations in the United States.

Arrangements have already been completed with the National Broadcaster's League, which has stations in twenty different states, to obtain the syndicated service as it is now being prepared in a Chicago studio.

The broadcasters will relay the regulation service, from prelude to postlude, on a precise schedule, each number beginning and ending at a precise time so that churches may employ their own sermon or their own offertory at option and tune in for the special music or sermon.

The regulation services, as they have been prepared by Mr. Rodeheaver, consist of ten or twelve records which are packed and distributed to the broadcasting stations affiliated with the league. Two specially constructed reproducing machines will carry the service through, one machine overlapping the other by a newly patented synchronizing device, so that there is no break at the end of one record and the beginning of another.

A number of noted divines have been engaged to deliver inspirational sermons and express modern religious thought. It is intended to have the service ready to supply churches in time for the mid-summer period.

Little Things That Help

Easily Constructed Grid Leak

There are times when you are experimenting with various circuits and you find yourself minus a grid leak. An efficient, variable and permanent grid leak may be constructed by cutting a piece of bristol board to the size of a grid condenser, punching two holes to allow it to be bolted on to the condenser, as in the illustration. Two washers make contact with the markings of a very soft lead pencil. The marking is allowed to protrude slightly around the edge of the washer. After the parts are assembled, it is connected to the set in the usual manner. When the set is

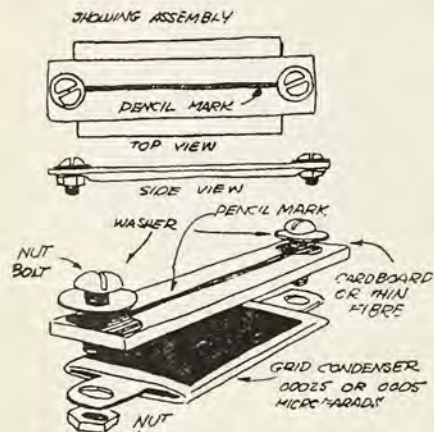

Figure 2. A grid leak of unusual efficiency and flexibility can be inexpensively constructed as shown.

turned on, the grid leak is adjusted by taking a pencil and drawing a line from the markings along the washer across the cardboard. The heavier the line, the less resistance, and the lighter line the higher resistance.

The action of the grid leak is to keep the grid of the tube from accumulating an excessively strong negative charge, which would make the tube inoperative, or as some prefer to say "paralyze" it. By listening in on the telephone receivers, it can be ascertained whether the leak is functioning properly. If the signal is "mushy," the reason is probably too much pencil marking, and if it thumps and knocks there is probably too little marking.

How to Eliminate Interference

Various methods have been tried to eliminate various kinds of interference. A new method has been originated, radically different from the conventional wave trap, which applies specifically to various forms of interference and tuning difficulties. This is the filter. For those who are troubled with interference from

stations using continuous waves, a filter of the type in Figure 1, A is recommended. This is constructed by having a winding of about forty turns of number 28, D C C wire, which will make a coil of about one inch in length. Over this coil there is wound about three or four layers of heavy writing paper, after which the coil is connected to a 23-plate condenser of good make. Over the larger coil a smaller coil, consisting of about from three to five turns, should be wound, which is connected to the set as indicated.

If you are having trouble from Spark stations, the filter in B, Figure 1, will usually assist in tuning him out. If your antenna is a small one, the addition of a 25-turn coil in the antenna lead, to bring its fundamental up higher, will probably help in making the filters a success.

bring the voltage up to 100 or 150 volts, then the internal resistance of these cells becomes very high; not so high for low frequencies, but high enough at radio frequency to need consideration. Therefore, shunting the battery with this large condenser, as shown in the

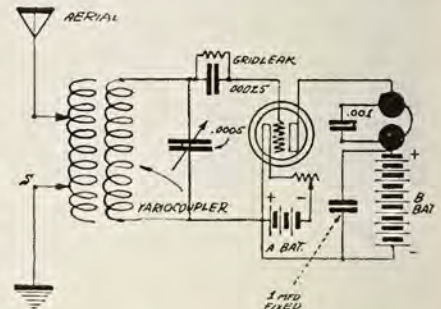

By-Pass Condenser for "B" Batteries

IN some circuits in which a high pressure is used on the plate, much better results have been obtained by shunting the "B" battery with a fixed condenser having a capacity of from 1-4 to 1 micro-farads. This is especially useful in cases where the pressure ranges from 80 to 150 volts. Using a fixed condenser of .001 M. F. across the phones is common practice and the reason for this is that the phones offer considerable impedance to the radio frequency current flowing in this circuit, and the condenser will cause them to pass around the phones. After getting past the phones it must also pass through the "B" batteries and if this battery consists of many small cells which are necessary to

drawing will help considerably. As the condenser used for this purpose has too much capacity to be used across the phones, it will not do to employ the one condenser for both, but two separate condensers of the proper capacities should be used as shown.

Correction

The circuit shown on page 10, in Figure 2 of the June issue should indicate a 23-plate vernier condenser, connected across the secondary circuit, from the left-hand side of the grid leak to the positive filament and bottom side of the coupler. The couplers should not be placed in inductive relation, but should be spaced not less than six inches. Number 22, DCC wire may be used throughout in winding the coils on the couplers.

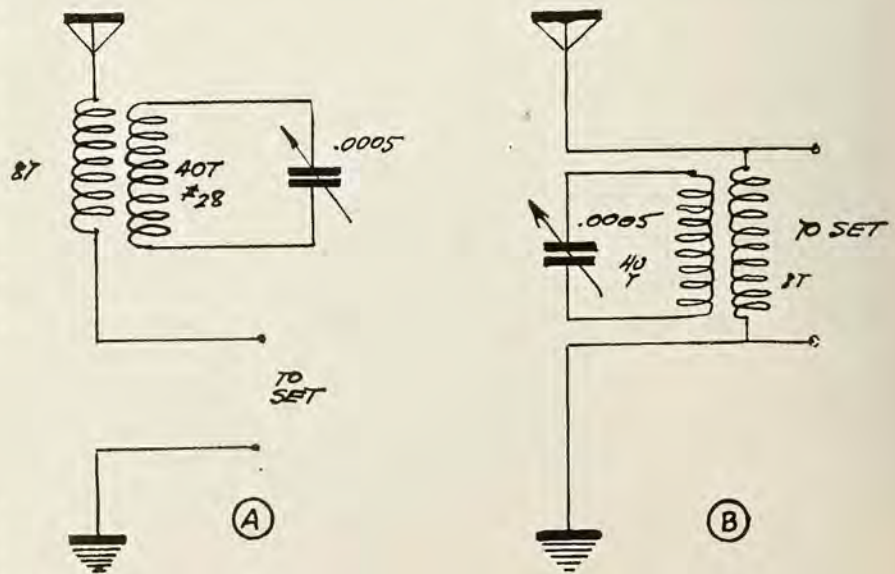
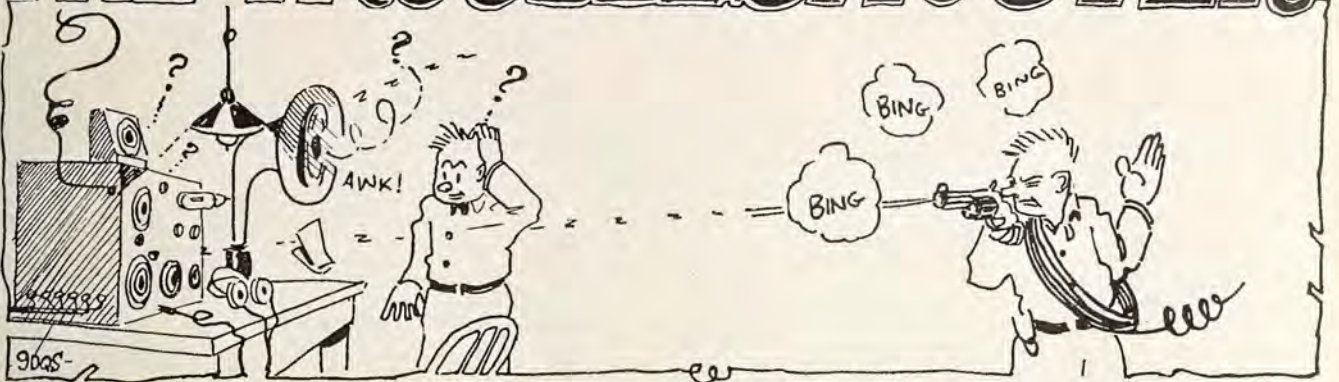

Figure 1. Two types of filter systems, which have been used with great success in eliminating interference. One or more of the type illustrated under A can be used for each interfering wave.

THE TROUBLESHOOTER



L. L. R. Monroe, Mich.

Question: I am just beginning the radio game, and I wish you would send me a diagram of a one tube set.

Answer: In Figure 7, I am printing a regenerative circuit, which will give very good results. L 1 is a coil of about

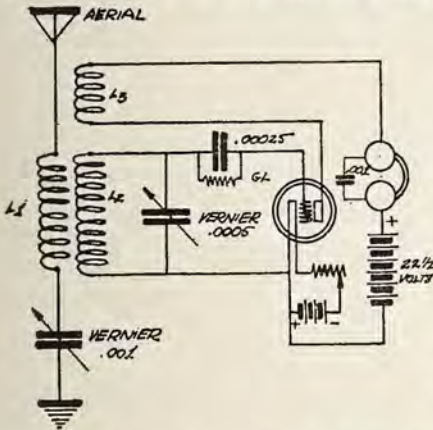

Figure 7. Many of our readers are asking for an easily constructed inexpensive one tube set. Here's one using two condensers and homemade inductances.

forty-five turns of number 20, D C C; L 2 is another coil of about fifty turns of number 22, D C C, and L 3 is a tickler coil having seventy-five turns of number 22, D C C. All coils should be wound on a cardboard tube three inches in diameter. The condenser connected across L 2 is a 23-plate vernier, while the condenser in the ground circuit is a 43-plate vernier. All the coils should be placed in inductive relation to one another.

I. C. M., Ventura, Ia.

Question: I am an interested subscriber to the Radio Age, and would appreciate it if you would give me a little advice on how to eliminate static, which is very violent in this section of the country now. I use an indoor antenna 150 feet long, with a single circuit regenerative receiving set. If you will send me a circuit showing how to eliminate this nuisance, I will feel eternally grateful to you.

Answer: As much as I would like to, I am sorry to say that I can not give

you a circuit which will cut out static. Static is a phenomenon which has been under observation and investigation for years in hope of finding some method whereby it may be eliminated in radio reception. The man who solves the problem is deserving of much praise and monetary returns. However, I am printing in Figure 2 a circuit which you will find is comparatively immune to atmospheric interference if properly constructed and operated. A complete description of this circuit appeared in the April number of Radio Age. You might try shortening the antenna you now are using, which affords less chance for accumulating static. Also while operating your set, keep the filament turned down as low as possible without interfering with the reception of signals. Can also advise that you listen in during the twilight periods, early morning and evening, before sunrise and after sunset. During this period, the static abates. Be sure that your antenna is properly grounded at all times, if the static is bad in your portion of the country.

G. W. H., Long Island City, N. Y.

Question: Please tell me what use to make of the three switch points on the grid circuit of my Reinartz set. As long as I have been using it, I have found use

for only the last one. The others only weaken signals or exclude them entirely. I replaced my 11 plate condenser with a 23-plate which enabled me to tune in WEAf at 492 meters, and also permitted me to separate the following four stations: WEAf, WJZ, WJY, WOR, and others. I have eight switch points on my antenna circuit and find use for about four of them. The others do me no good. What are they there for? I use an L 1500 honeycomb coil in the plate circuit between the detector and first state of audio frequency. Is this a new stunt? It increases the tone and volume of the set. Why is this?

Answer: The reason you find that some of the switch taps on your set are not all active is that the designer wished to provide for different types of antennas and systems, and therefore made the set flexible so as to function with practically any system. Probably if you had a different antenna system you would have to use entirely different switch taps in tuning. The honeycomb coil in the plate circuit is not a new feature, but is often a good one. Would advise that you use a smaller coil in this circuit, as I am sure you will get better results. The introduction of more inductance in the plate circuit, in this case, effects greater ease in making the set oscillate

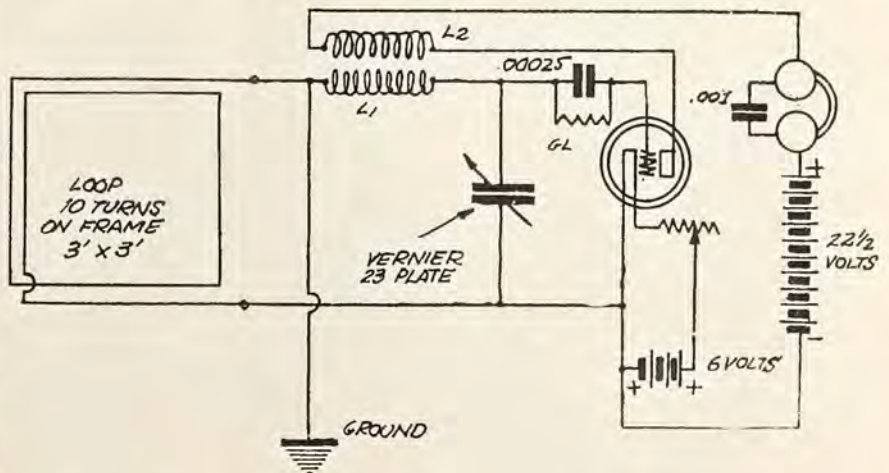

Figure 2. The one tube loop antenna set, described in the April issue, can be used to advantage for excluding static and interference, and makes an ideal portable set for summer use.

or better, than some of the conventional circuits now in use. Great care must be exercised in constructing them.

Mrs. C. E. B., Stockton, Ill.

Question: I have a Westinghouse Aeriola SR receiver, type RF. Can you please recommend any special hookup for one step of audio frequency amplification to be used with the headset, and two step to be used with a loud speaker?

Answer: I am printing, in Figure 3,

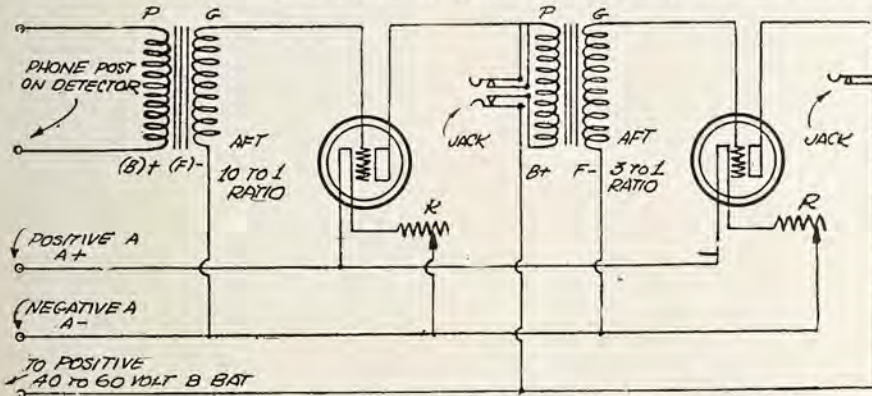

Figure 3. A two stage audio frequency amplifier, constructed with binding posts as in the circuit, can easily be connected to any set, as shown.

a diagram of a two step amplifier, making provision for the use of either headphones or loud speaker. The phone posts on the detector of the set you now have should be connected to the designated posts on the amplifier. The rest of the connections are plainly shown in the diagram.

L. P. G., Chicago, Ill.

Question: I am having trouble with a sputtering and cracking noise in my set—consisting of a two stage audio frequency, with a regenerative detector using honeycomb coils. I have used my B batteries on two other sets, and have no trouble from them. I have tested the transformers, and they seem to be OK. They are spaced more than three inches apart in the set. All connections are very short. I use a C 300 for detector and the U V 201 A for amplifiers. I wonder if you could help me locate the misery causer. I don't think it's static, because I use an indoor antenna which, by the way, is 160 feet in length. I have watched your magazine very closely every month in hope of finding something which would apply to my case, but have found nothing. What would you suggest?

Answer: I am of the opinion that the limitations of your set are due to either poor connections, faulty transformers or the improper use of the U V 201A tubes in the amplifier circuit. Would advise that you take a hot soldering iron and go over each of the connections, making sure that it is firmly and well soldered. Sandpaper the resistance wires and slider on the rheostats. If you are using jacks, make sure that no flux or soldering paste remains on the lugs, as this is often the cause for set noises. Reverse the tickler coil in the set to find out if it is wound in the proper direction. Try it both ways. Make sure that the prongs on the tube sockets are clean and make good contact. Faulty trans-

formers might be the cause of your trouble, this being determined by the use of other transformers. From your letter I cannot tell whether you are using the proper rheostats on the U V 201 A tubes, but will say that if you are using the ordinary rheostat, would advise that you turn them up only to make contact with the resistance wire on the rheostat. The reason that this is necessary is that too high a filament potential will render the tube inopera-

tive, and the only way to make the tube come back to normal is to burn the filament at normal brilliancy for a period of time with the B battery off. This will bring back the filament emission of electrons. Make sure that the A battery is correctly connected, as the reversal of polarity makes the amplifier inoperative, giving only a lot of noises. A negative charge must be sustained on the grid of the amplifier tube in order to make them function properly. Of course your trouble could be static, but you will have to determine that for yourself. If you are getting noises on one set and not on the other, with simultaneous operation, the trouble is not static. If you hear them with both sets, you may be sure that you are having trouble with atmospheric, and the only way to avoid them is to put in a circuit as in Figure 2.

H. J. J. Crestwood, Ky.

Question: In the Erla reflex circuit

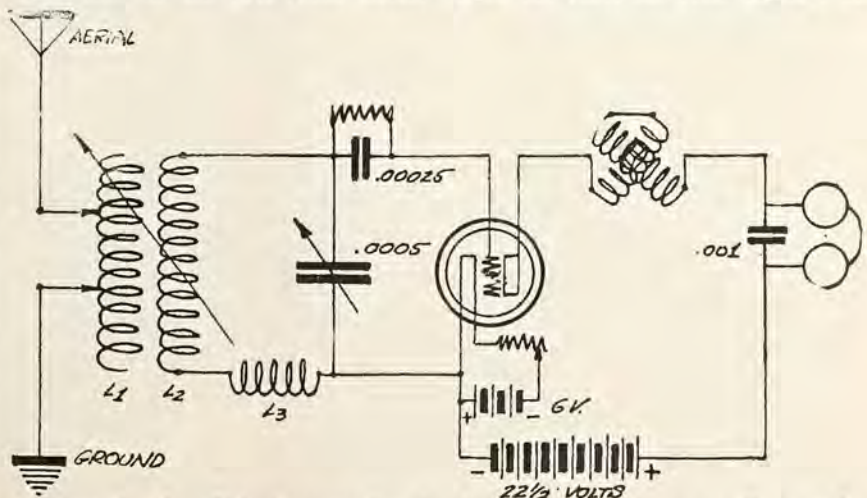

Figure 6. An efficient regenerative circuit using a condenser across the secondary of the variocoupler with a 25 turn honeycomb coil, which tunes very closely.

in the May number, your drawing shows the transformer markings as being minus and plus, but the transformer is not marked this way. Marking on the transformer are A and B. How do they connect them with these markings?

Answer: The connections, as you indicate, are the same as on our diagram with the exception that our diagram was a little more specific. The marking A on the transformer indicates the filament negative or A—while the marking B on the transformer indicates the plate battery positive, or B+. The AF transformer you mention in your letter will be satisfactory in the circuit.

B. R. C. Iroquois, Iowa.

Question: I have a three-stage audio frequency set which has only one variometer and no coupler, and I would like to know if the circuit can be rearranged to bring in long distance stations by the addition of a variocoupler. Please give me a circuit showing how this is done.

Answer: I am printing, in Figure 6, a circuit which will bring in long distance stations using the apparatus you now have, with an addition of a variocoupler, one condenser and a small honeycomb coil. The audio frequency is added in the usual manner, the input of the first stage of audio frequency connected to the phone posts on the detector. In this circuit, L 1 and L 2 are the primary and secondary of a variocoupler respectively, and L 3 is a 25-turn honeycomb coil. The condenser across the secondary of the variocoupler is a 23-plate vernier. The variometer in the plate circuit makes the set regenerative.

F. H. Chicago, Ill.

Question: Can you give me a detailed drawing of a tuning system with which I can tune out KYW, WDAP, and WMAQ while they are sending. I have tried every circuit nearly, Flewelling, Reinartz, Reflex and Regenerative; but no use, I don't think it can be done. Have been trying RF and AF, but that don't do it. I live only two miles from KYW and it surely blankets everything else. On silent nights I can get Kansas City, St. Louis, Memphis, and Minneapolis on one tube, but other nights I can

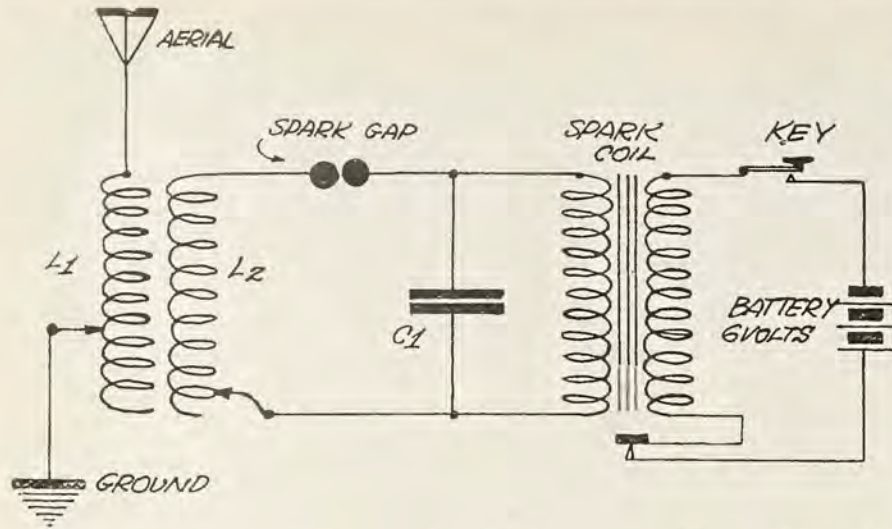

Figure 5. A spark coil if connected up in this manner, makes an efficient short distance transmitter. The ordinary automobile spark coil, with vibrator, can be used.

not tune out the local stations to get any DX

Answer: Your location is a very bad one from an interference viewpoint, and about the only recourse you have is to put in a loop receiver, something on the order of this month's circuit, with which I am sure you will be able to exclude this excessive interference. You might try using a wave trap or a filter in the circuits you now are using, and also to decrease the length of your antenna, so that it will tune more sharply.

F. N. Sta. D. Milwaukee, Wis.

Question: I understand that an automobile spark coil can be used for a transmitter. How is it hooked up?

Answer: I am showing, in Figure 5, the proper connections for a spark transmitter, which will give a very sharp wave, with a minimum of interference. L 1 is a coil of about twenty turns of number 12 solid copper wire wound in a pancake form. L 2 is another pancake coil of number 6 or number 8 solid copper wire of about six turns. C 1 is a tinfoil and glass condenser, having a total of about thirty sheets of tinfoil five by six inches, fifteen sheets on each side. To transmit you must have a license, which will be furnished free of charge by the radio inspector of your district. You must be licensed, as a heavy penalty is provided for unlicensed stations.

S. S. Quincy, Ill.

Question: I wish to mention that I have received my first issue of Radio Age, and find it chock full of radio knowledge. It certainly cannot be beat. I would like to have you go over the enclosed diagram showing how I have connected up my set, to ascertain whether it is correct. I have connected my set up this way and I do not get any results, and would like to know if it is the set or the circuit. The RF transformer is of the air core type. I cannot possibly locate the trouble after having gone over the wiring with the utmost care and finding no errors. Can you set me on the right track?

Answer: You bet we can S. S., be-

cause your diagram is not correct. Connect up your apparatus as in Figure 4, and you will certainly get results. The three-plate condenser across the primary of the RF transformer will afford greater ease in tuning. Potentiometer should be from 200 to 400 ohms. L1 and L2 are the primary and secondary of the variocoupler. The condenser across the secondary of the variocoupler is a 23-plate vernier.

C. W. J. Gfens Falls, N. Y.

Question: I recently hooked up a Reinartz set, consisting of a detector and two stages of audio frequency, according to your instructions, and had the best of results. I am trying to make a change to the hookup to a RF amplifier, detector and two stages AF, using Rasla transformers, 13 and 5 plate condensers U V 201, 200 and 201 tubes, respectively, but all I can get with set hooked up as it is, is a beat note in the phones. This note can be varied by turning the condensers. Local experts say that this beat is caused by an open circuit, but I cannot believe it, as I have tested out the circuit for breaks. I have tried several sizes of condensers in the grid, have a variable grid leak, tried a small choke coil in the plate circuit of the detector and also tried to put in a small

choke coil between the radio tube plate and the primary side of the RF transformer. Can you enlighten me as to the cause of the beat note, and its cure? All I have been able to get is Schenectady, which is about fifty-two miles away, and I get them so faintly that I just about could hear them. In what way would larger condensers affect the circuit? Radio is supposed to reach farther, but can I get volume as I had before I tried to change?

Answer: The beat note you speak of is probably caused by the RF amplifier in your set acting as a detector, rectifying the signal instead of amplifying it. The reason you caught Schenectady is that probably your RF tube and detector tube were tuned to the same frequency, thereby allowing the signal to slip through. Larger condensers in the circuit will increase your wave length. If you will connect up your set as in Figure 1, you will get the advantage of both added volume and increased range. The circuit shows the connections for W D 11 tubes, but you will have only to make it apply to your source of filament potential. No changes in the circuit will be necessary.

Kinks

One of our readers, who lives in an outlying district, found that he had no spaghetti tubing with which to insulate the set he was constructing, and in order that he might quickly have a substitute, purchased common soda straws from a local drug store, shellacked them, and used them in the regular way in place of the regular tubing.

Another one of our readers, Clarence Peterson, says that a vernier on the condensers and variometers of your sets are not needed, if you have a lead pencil having a soft rubber eraser on it. He says: "Place the rubber firmly against the panel, with the side of the eraser against the dial. A slight turn on the pencil will give a very small movement of the dial of the condenser. It is about as close as any vernier will give. It also does away with a great deal of body capacity, because your hands are not near the dials of the set when the pencil is used."

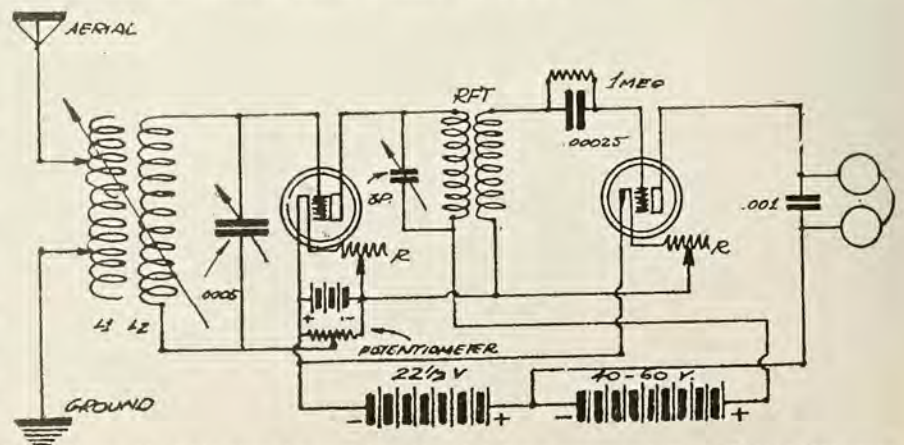

Figure 4. This circuit shows how to use a plain variocoupler in a radio frequency detector hookup.

Pickup Records From Our Readers

Spartanburg, S. C.

Radio Age:

I have just sent in my subscription for the Radio Age, and wish to say that it has more diagrams and helps to the radio BCL than any other book now on the market. I have been buying it heretofore on the stands, but do not want to take the chance of missing a copy, therefore my subscription.

I have a set with which I am getting good results, the Armstrong regenerative circuit, which I have modified slightly, and which I find works better. With this hookup I have received the following stations: KDKA, KLX, KYW, WAAB, WAAC, WAAD, WAAL, WBAP, WDAJ, WEAJ, WGAQ, WGAS, WGF, WGM, WGY, WHAS, WHK, WJAX, WJZ, WLK, WLW, WMAQ, WOC, WOH, WOR, WOS, WSB, WWJ and Canadian CKAC.

WILLIAM SIBLEY LAW,
Saxon Mill, Spartanburg, S. C.

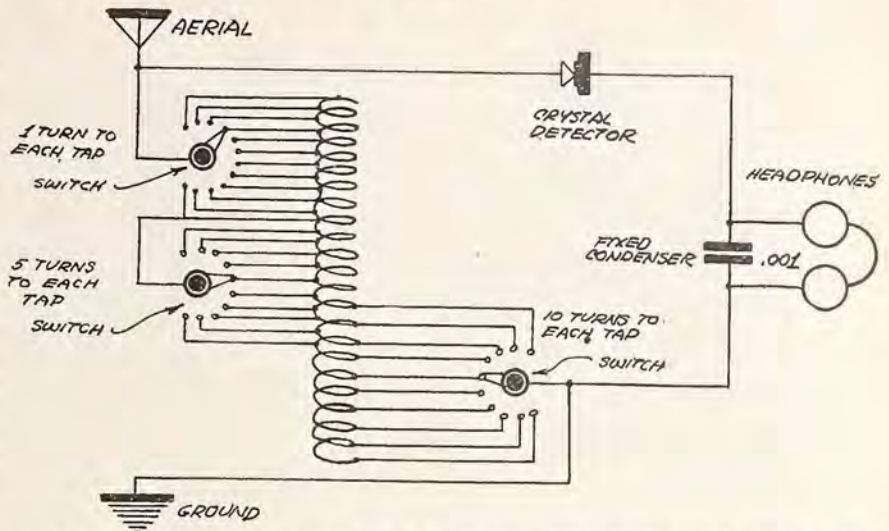

Figure 2. Mr. Smith's adaptation of the Bureau of Standards crystal set, with which he is getting unusual results.

Danvers, Ill.

Radio Age:

A variety of devices for amplifying the sounds received through the receiving sets are now on the market for the choice of the owner of a radio receiving set, but if his means are limited, the ideas illustrated herewith may be applied at a total expenditure of less than a dollar.

The only material required is one or more small force cups, such as can be bought from any plumber or hardware store. Usually these cups are mounted on a wooden handle, as in A, Figure 1. The handle is removed as it is not used. Between the handle socket and the hemispherical cup there will be found a dividing wall of rubber, which must be cut out, as in B. The head set is fitted inside of these cups which are then slipped over a T arm as in C, one of the

arms being connected to the phonograph horn or other horn to be used. If only one receiver is used, no T arm is necessary, the cup being fastened right on to the tone arm of the phonograph.

GILBERT R. HEDRICK,
Danvers, Ill.

Philadelphia, Pa.

Radio Age:

I am enclosing a pencil drawing of a modification of the Government Bureau of Standards on the simple tap and coil crystal hookup. This consists of a coil tapped as follows:

- 10 tens.
- 10 fives.
- 12 single taps of unequal lengths.

Three switch buttons or levers are required instead of two. A complete circuit is obtained by breaking the last tap on the five and connecting one end

to the last five tap and the other end to the center of the five switch lever, as in Figure 2.

While I fail to see any additional increase in tone, I do find that there is a greater variety in combination tuning and also if an additional wrapping of about thirty turns before the first taps are taken on the ten side that all wave lengths contemplated will be taken care of with ease.

I would like to have your readers follow this hookup and report their tests to your paper. Most of the experimenting I notice has been done with tube sets, and while I have been connected up with tube sets for about two years I still stick to my original crystal set as I enjoy the freedom from tube noises and other machine noises so frequent on the average tube set. My own special crystal set is very loud; in fact, with a

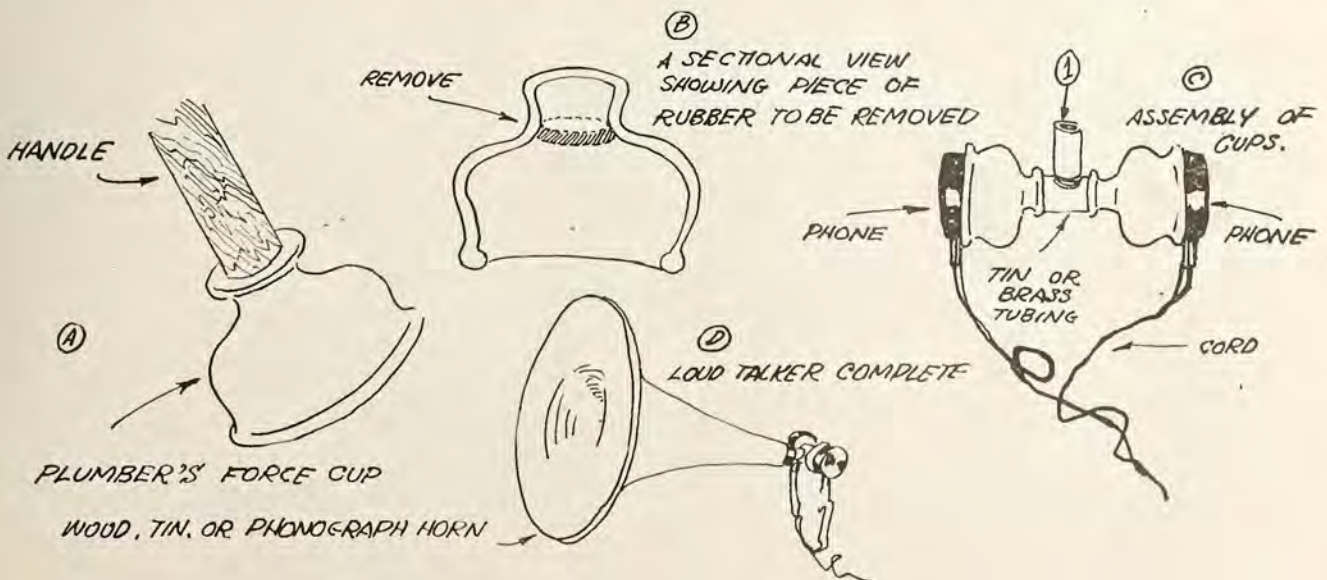

Figure 1. An inexpensive, easily constructed and novel loud talker can be constructed using parts obtainable in the average plumbing or hardware store.

pair of ordinary phones I can place the phones on the wall, face out, and understand everything coming over the air, throughout the room. Other crystal set owners all declare that they cannot get theirs nearly so loud.

W. P. SMITH,
Philadelphia, Pa.

That Hopwood Circuit

MANY of the eastern radio fans are getting quite a kick out of a new circuit which was not supposed to be. A fan by the name of Hopwood, who lives in Philadelphia, while trying to unravel the mysteries of a blue print, got so badly tangled up that he got the secondary of his coupler hooked up to the plate instead of the grid, accidentally producing a feed-back, which according to reports, puts the other feed-back circuits way back into the crystal detector class.

Unlike most fans who have glory suddenly thrust upon them, Hopwood doesn't say, "I told you so," but he wants to know what it is all about and has called into consultation radio engineers from far and wide to tell him why it works. Anyway, we must give him credit for giving us one of the most efficient dry cell tube circuits ever slipped over, and after all what do we care how it was done, if it does what they say it will do? He has rendered a great service to the army of radio bugs, so let us all give three cheers for Hopwood!

The accompanying diagram shows how he did it, and the simplicity of the circuit will immediately appeal to those enthusiasts who are always looking for something new. It will be noticed that the variometer is connected in series with the primary of the coupler. There is, however, no inductive relation between the two. The grid is connected to the aerial and the plate to the secondary of the coupler.

In Boston!

The Boston Post publishes a poem which is entitled "Modern Mother." The verse shows how mother nowadays passes up her knitting for a three-tube receiving set. The first stanza starts like this:

We never could educate mother
To give up her old-fashioned way;
A little black bonnet with lavender on it,
And a shawl, she was dressed for the day.

It is none of our business but mother must be a hardy soul.

WMAQ Moves

Station WMAQ, which has been located on the Fair Store building, Chicago, has been removed to the La Salle Hotel. Three big Chicago hotels have now added radio broadcasting stations to their activities, The Drake, the Edge-water Beach and the LaSalle. A hotel station has the advantage of an orchestra available each evening for jazz stuff.

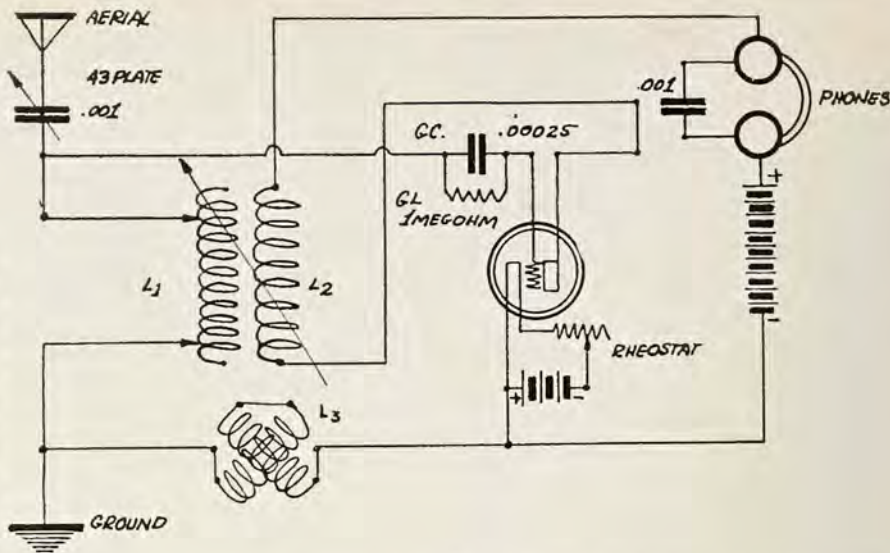

The Hopwood circuit, showing the unusual connections of the instruments used.

Storing the Battery

Now that summer is approaching, there may be some who will not use the regular six-volt storage battery but use the dry cell ones instead. If you are contemplating doing this, take the advice of the battery expert in the Crosley Manufacturing Company's laboratory and do the following things:

Charge the 6-volt battery to its usual full capacity.

Drain the cells of their liquid.

Place the liquid in an airtight receptacle.

Be careful not to spill the liquid, as it will destroy clothing, rugs, etc. When ready to use again, divide the liquid into three parts and pour into the battery cells, proportionately, and fill up the cells until the plates are covered with distilled water, and then recharge.

Radio as a Teacher

French-speaking residents of Canada are learning English from the announcers of WGY, according to a letter received recently by the Schenectady radio broadcasting station of the General Electric Company.

Mrs. R. Normandin, a resident of Shawinigan Falls, Quebec, writes, "Many persons are taking advantage of radio to learn to pronounce English, especially from your station. Our daughter, aged four, speaks French only, and she startled us recently when she said all of a sudden, 'WGY, Schenectady, N. Y., one minute, please.'"

Those in charge of radio broadcasting activities of the General Electric Company realize that the right to broadcast carries with it the responsibility to offer something worth while. An earnest and conscientious effort is made to provide good music, to give variety of entertainment and to give helpful addresses. Announcers strive to pronounce all words correctly. Before an announcement is made or an address delivered, the announcer goes over the manuscript.

National Transformer

Construction of this audio-frequency amplifying transformer is very rugged and neat. The shell type of construction is used, the core being made of laminated silicon steel. The coils are neatly wound and impregnated, with connections to the posts well soldered.

The instrument is completely enclosed in a highly nickelplated case, held together by two nuts and bolts, and nicked binding posts for the connections are plainly marked.

Extensions of the case in the form of feet are provided for mounting purposes. The transformer has a ratio of three and one-half to one and operates very satisfactorily, both as to volume and quality of amplification. The approximate over-all dimensions are $2\frac{3}{8} \times 2 \times 2\frac{1}{2}$ inches.

It is approved by the Radio Age Institute experts.

It is manufactured by the National Transformer Manufacturing Company, 154 Whiting Street, Chicago, Ill.

Erla Contest

In order to give all readers of Radio Age an opportunity to compete in the Erla prize contest, announced in the July issue of the publication, the closing date for this contest has been extended to August 10. Winners of the contest will be announced in the September issue.

For those who missed the June issue, the Erla contest offers for the best explanation of the action of the Erla Duo-Reflex circuit, one Erla Duo-Reflex receiver, mounted in a beautiful mahogany cabinet. For each of the ten next best explanations, one Erla Reflex transformer will be awarded.

Judges of the contest are F. D. Pearne, Technical Editor of Radio Age and E. J. Wiggins, Chief Engineer of the Electrical Research Laboratories. Instructions for building the Duo-Reflex circuit may be obtained from any leading radio dealer or the Electrical Research Laboratories, by writing for Bulletin No. 13.

Amateurs Increase

Washington, D. C.—Lest some fans believe that the reception of broadcasts is the only popular phase of the radio art, be it known that amateurs are still entering the game of "key pounding" at the rate of nearly three hundred a month. Since January 1, 1,334 amateur licenses have been granted by the Department of Commerce, and on June 5, there were 18,232 such stations in the United States.

The distribution of amateur stations by Districts June 5, was as follows:

District	Headquarters	Total
1.....	Boston.....	2,490
2.....	New York.....	2,629
3.....	Baltimore.....	1,994
4.....	Norfolk.....	444
5.....	New Orleans.....	941
6.....	San Francisco.....	2,172
7.....	Seattle.....	901
8.....	Detroit.....	2,932
9.....	Chicago.....	3,729

Total.....18,232

The above table does not include special amateurs, of which class there are 201, no new licenses having been issued recently. It has been decided by the department that hereafter district radio supervisors will issue special amateur station licenses instead of the Washington office.

The waves assigned to special amateurs are between 150 and 220 meters for use in CW telegraph. Regular amateurs operate on 150 to 200 meters.

New Tubes for Old

W. C. White, of the research laboratory of the General Electric Co., made an address from WGY recently in which he announced that the company was making a collection of tubes and offering new tubes for old ones which were different enough from present tubes to be of value as a part of the collection.

This is what Mr. White said:

"For some time past, we have been making a collection of vacuum tubes to illustrate the development of this interesting art. A number of years from now such a collection will be of great interest and of considerable historical value.

"We would like to ask radio fans to assist us in making more complete this vacuum tube collection.

"It is natural, however, that we are only desirous of obtaining additions to this collection and, therefore, are interested only in tubes of other than General Electric manufacture. What we desire to obtain are tubes of very early manufacture, tubes of unusual design and those of other countries, particularly Italian, Japanese and German. It is not essential that these tubes be in operating condition. The filament may be burned out or the vacuum impaired, but they should be in satisfactory mechanical condition.

"If any radio fan has such vacuum tubes, I shall be very glad to have them write me, describing their tubes briefly and if they form an addition to our collection we will write their present owners offering them on receipt of their tubes

to send them in exchange for each one of interest to us, one of the new UV-199 radiotron tubes. We will also include a socket for each tube and complete operating instructions. Address all communications relative to tubes of possible interest to us for this collection to WGY, General Electric Company, Schenectady, New York.

"It is particularly requested that any who have such tubes should write first and wait for a letter from us before shipping their tubes to us to learn whether they have any historical interest as an addition to our collection."

Records by Cruiser

Washington, D. C.—Naval radio experts are delighted with the performance of the radio equipment on the new scout cruiser, Omaha, which recently broke all long distance records in transmitting during her shake-down cruise in the Pacific.

While maneuvering at sea, off the coast of Washington, the newly installed radio transmitting sets were given a thorough test. Code messages transmitted with the 20 KW arc set, such as the larger naval craft are now equipped with, were copied by all naval radio stations along the west coast, from lower California to Saint Paul, Alaska, and on the East coast at Bar Harbor, Me., Washington, D. C. and Key West, Fla. One of the stations reached was San Diego, 1,800 miles away from the Omaha. This new cruiser's arc was copied by the battleship, California, which was 1,800 miles distant, but it is reported that she could not pick up the California's replies.

Not only in code dispatches did the Omaha's radio experts excel, but with her 300-watt tube set, spoken messages were transmitted to Pearl Harbor,

Honolulu, 2,300 nautical miles distant. They were also heard at Key West, Fla., approximately 2,100 miles over land and sea.

Part of the credit for the long distance work is attributed to the 180-foot wooden masts, which carry the Omaha's aerials, almost fifty feet higher than the steel masts on battleships. The mean effective height on the Omaha is better than 100 feet, it is stated by naval experts. Her radio equipment is also installed on the top-side and not below, eliminating long cable and wire leads.

CLASSIFIED ADVERTISEMENTS

Six cents per word per insertion, in advance. Name and address must be counted. Each initial counts as one word. Copy must be received by the 5th of month for succeeding month's issue.

HELP WANTED

Ambitious men and women 18 up wanted for U. S. Government Permanent Jobs. \$95 to \$192 Month. Paid summer vacation. Short hours. Pleasant work. Common education sufficient. Experience unnecessary. Write today sure for free list of positions obtainable. Franklin Institute, Dept. W115, Rochester, N. Y.

PATENTS AND TRADEMARKS

"Patents and Trade-Marks," 64-page Book free, Excellent References. 23 years' experience. Robb, Robb & Hill, 1415 Hanna Bldg., Cleveland, Ohio, 952 McLachlen Bldg., Washington, D. C.

SUBSCRIPTION AGENTS

We want representatives in every community to obtain subscribers for Radio Age. Excellent opportunity for radio enthusiasts to make good money quickly. Write Radio Age, Inc., 64 West Randolph Street, Chicago, Ill.

BOOKS

If you have not bought your Reinartz Book, fully illustrated with hook-ups and clear description of how to make this popular circuit, send \$1.50 in money order or check and we will send you the booklet "Reinartz Radio" and place you on the subscription list of Radio Age for six months. Address Radio Age, 590 N. Dearborn Street, Chicago, Ill.

RADIO OUTFIT AND SUPPLIES

Radio Solder for construction and repairing radio outfits. Three six inch bars 25c postpaid. Hamilton Lead Company, Hamilton, Ohio.

Reinartz Book FREE

Reinartz Radio Book with Hook-ups—best book on best circuit—written and illustrated by Frank D. Pearne. If you want one free sign the coupon below and get the book and one year's subscription to Radio Age for \$2.00.

RADIO AGE,
500 North Dearborn St.,
CHICAGO.

Please send me FREE one of your Reinartz Radio Books and send me Radio Age for one year. I want to take advantage of this Special Offer. I enclose \$2.00.

Name.....

City.....

Street and Number.....

A New Bug

By ROBERT J. STANTON

Since the flea was found to be the fastest thing on legs and to have a strong attachment to orphaned dogs, expert scientists, after thousands of years of patient labor, employing the search and seizure act, have succeeded in ferreting out from the dim recesses of swamp, forest and jungle a veritable myriad of bugs.

Two years ago, the latest triumphant discovery of these insect chasers, who are said to be even more expert with a net than the saltiest fisherman of Newfoundland, was the golf bug. The larvae of this bug was found to be the male human, with more stomach than hair, and more time to kill than work to do. The habitat of the specie was a vast acreage of well-kept turf, dotted here and there with shell holes, ponds of water, and other topographical irregularities,

which science found to be necessary in the complete formation of the adult bug.

After its emergence from the larva stage, the golf bug flies around the well-preserved turf, usually confining his jaunts from the colony to late afternoons and Sundays, in spite of vigorous protests from the female species. The female is the protector of the home and does all the work, and sees the male bug only on very rare occasions during the summer months. The habits of the male of the species, during the winter, are as yet unknown, due to its exceeding ferocity during this period. However, it has been found that a few migrate to the southern part of the country in November and fly north again in May.

The latest discovery of science in the world of insects, however, occurred about a year and a half ago, when an expert, searching in the vicinity of Pittsburgh, found a radio bug. The insect was a male adult, having a close resemblance to the golf bug, except for larger ears and a marked increase in the size of the finger tips.

Noting these two peculiarities, the scientist patiently studied his new discovery from concealment and learned that the enlarged ears were due to the bug's habit of clamping a pair of round black discs to his head, the discs resting tightly over the ears, spreading them out to a considerable extent. The enlarged finger tips were due to a continual twisting of several knobs on the front of an oblong-shaped box to which the black discs were attached by a green cord. Small lights in the box glowed dull red and occasionally the glow would cease, causing the bug to become greatly enraged.

Another peculiar characteristic of the new bug is its strange chatter, of which the major note sounds somewhat like KYW, KDKA, heterodyne, regenerative, frequency and tuning in. Several months after the discovery of the first bug, the scientists found that the entire country was literally infested with vast hordes of these bugs, and learned that whenever two of them were together, and one of them made the tuning in noise, a quarrel

usually resulted which occasionally lead to serious injuries.

A radio bug does not spend all its time around the box with the cord and discs, however, as it is seen climbing around the roof of its home during a greater portion of the day. Some of the bugs are very agile in climbing slender poles attached to the top of their homes and adjusting wires suspended from them. The larger bugs do not seem to have this agility, however, and often fall to the roof amid wild howls.

After much research scientists have found that the Westinghouse Electric & Manufacturing Company was responsible for the huge swarm of these bugs, which now infest the United States. Other companies also operate the same kind of laboratories used by the Westinghouse company, which inoculate the air with a substance on which the bugs thrive.

Operates in Duplex

Highly gratifying results have been secured with a new model high-power tube transmitter installed on the battleship, Wyoming, and used in regular traffic.

"In fact," states a naval report, "some results were unexpected, such as ability to receive on the same vessel, during full power operation of this tube, rating about 5KW." Numerous broadcasting stations transmitting on 40 meters were tuned in in the auxiliary radio room, while the big transmitter, installed in the main radio room, was supplying thirty-six amperes to the main antenna on a wave length of 507 meters. The receiving set in the auxiliary room was equipped with an amplifier, consisting of three stages of radio-frequency and two stages of audio-frequency.

"This condition allows duplex communication, which has actually been put in practice on the Wyoming and will be further developed on the Colorado and West Virginia," the report states.

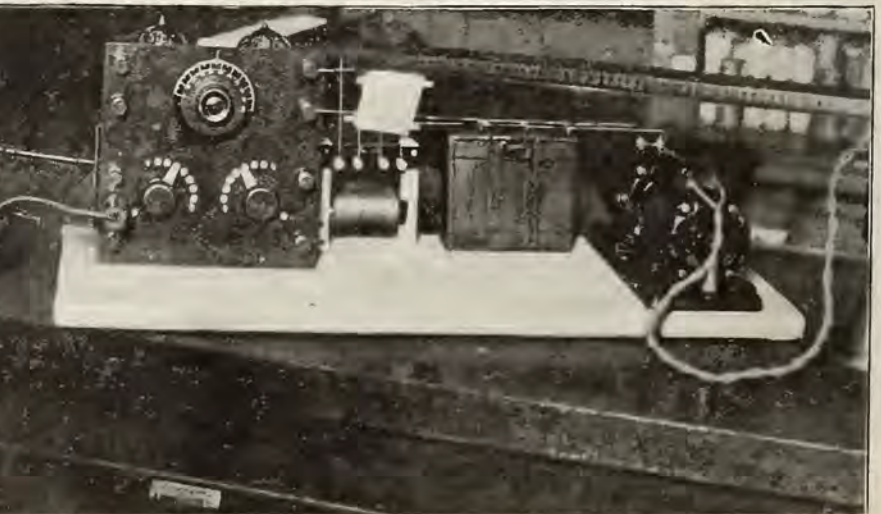

Radio station 9-CEX, with a range of from fifty to seventy-five miles. It was made by E. W. Applebaum, of the Illinois Fixture & Electric Supply Co., Chicago, and is said to be the smallest licensed and registered radio station. (U&U Foto).

"Radio Central"

By CARL H. BUTMAN

Washington, D. C.—The sign over the door reads: "Radio Central—No Admittance," but accredited correspondents may look around the new radio central office of the Naval Communication service in Washington, if they keep quiet.

It is located in the big naval building at Nineteenth and B Streets, near the Lincoln Memorial—sixth wing, second floor rear, to be exact—and is approached through the several offices of the Communication service, one of which is that of Rear Admiral Ziegmeier.

From this office issue all naval radio messages from the capital, the transmitters at Arlington, Annapolis, Sayville, and several smaller stations are controlled directly from keys installed here. Annapolis and Sayville are high-powered, trans-continental and trans-oceanic stations, and Arlington, which is a link in the long costal chain, is used for medium distant communication with Norfolk, Charleston, Key West, New Orleans and Guantanamo and ships at sea, over spark, arc and tube sets.

Long distance reception from the many outlying stations of the naval chain is secured through six big receiving sets, known as RB type tube receivers, located in six separate rooms in different sections on the third floor of the naval building. From these sets, leads run to the central switchboard and as many operating desks in the central office. The RB receivers pick up the messages on eight-foot loops installed directly overhead on the roof of the building. These coils are directional and may be rotated from the rooms below by a rod when tuning in. Each set is put in operation, watched and shut down by a monitor engineer who makes continual rounds of the six separate rooms. A continuous watch is kept on these large sets, each covering a special station. One listens in on San Diego on 9,800 meters; another for San Francisco on 10,500; a third on San Juan on 8,785; a fourth for Balboa on 7,000; number five on French stations on 15,000 and number six is used for emergency, and experimental work and ships. Each inside wire leads from the switchboard to the operator's desk, where phones, typewriters and transmitting keys are installed.

The efforts of the naval communication service are for reliability and efficiency in handling messages, and the sets and operators work on certain circuits all the time.

Two shorter wave sets, of SE 1420-C type, are installed in the central office, being connected with aerials on the roof above. These sets are used for receiving neighboring stations and ships on the Atlantic.

In Radio Central a busy scene confronts a visitor; some keys are clicking and some of the operators are typing messages from distant stations. Messengers come and go with dispatches from Government Officials to our representatives in foreign countries and our ships in the seven seas.

The long land line formerly used between the old receiving station at Bar Harbor and the Washington office, has been discontinued at a large annual saving. Bar Harbor is now a coastal and compass station and handles no long distance messages, although the equipment is left in place in the event of emergencies or war requirements. Washington is literally the naval radio central for the country today.

Radio at Shrine Convention

Radio, like practically every other activity, took part in entertaining the Shriners at the Nation's Capital last week. Among the features was the reception and amplification by a receiver in the Garden of Allah of a broadcast message from the President read by an aviator in a plane flying over the parade.

A local engineer installed a receiving set and a large loud speaker on the roof of the Albee Building. This apparatus amplified music and other matter picked up from nearby broadcasters.

Part of the Army's night parade exhibit was the miniature radio controlled cart, made by the Dayton Air Station, which was operated from an auto some distance in the rear.

NAA put on special programs for local consumption and events scheduled for the convention were broadcasted on opening day.

Many visitors were fooled by the loud speakers, erected along the Avenue by the local telephone company for an amplifying dance music played in an auditorium and relayed by wire to the many horns; it sounded something like radio but was actually wire telephonic transmission from local sources.

Proper Antenna for Tuning

(Continued from page 8.)

distant one, the signal from which would, of course, be very much weaker than that from the nearby station. For the first condition, it will be found that with the average regenerative receiver, ample strength will be obtained from an antenna which is not over ten or fifteen feet high, or it may even be entirely within an ordinary living-room. The second condition, however, is a much more severe one and requires either a location where antenna of not over fifteen or twenty feet high will not be unduly shielded, or where the lesser selectivity of a high antenna will be counter-balanced by a more elaborate and selective receiving set.

WHY TAKE CHANCES WITH INFERIOR APPARATUS?

The successful operation of your set depends largely on the quality of the parts used in it. One poor part may mean trouble and the quality of every part used should be carefully investigated before buying.

**NATIONAL
Audio Transformers
Assure Perfect
Amplification**



**Tested and Approved
By Radio Age
Institute**

When buying transformers be sure you get National. This transformer has a long successful record behind it. It has been tested by Mr. F. D. Pearne of the Radio Age Institute and many other leading radio authorities in laboratories throughout the country and has been approved by them as being a product which they are willing to recommend to those wishing a high quality transformer. You are therefore playing safe when you use the National in your set.

Give equally good results in any circuit wherever an audio frequency transformer is to be used. Can be used on any stage of amplification and with any type of tube.

Price \$4.00 Postpaid

Get them from your dealer. If he hasn't them in stock send your order direct to us giving your dealer's name.

**NATIONAL TRANSFORMER
MANUFACTURING CO.**

154 Whiting St.

Chicago, Ill.

CHARGE YOUR BATTERY

(RADIO OR AUTO)
at HOME for a NICKEL
The HOMCHARGER
POPULARLY PRICED—PAYS FOR ITSELF
SEND FOR THE AUTOMATIC ELECTRICAL
FREE BOOK THE AUTOMATIC ELECTRICAL
DEVICES CO.
146 W. THIRD ST.—CINCINNATI, OHIO

Old Doctor Radio

"Doctor, I'm so restless. Can't I have something to put me to sleep?"

"Certainly, but not morphine. Let's try a concert instead."

The doctor fixes a headpiece over the patient's ears, tunes up the radio to catch any music that may be in the air anywhere from New Hampshire to Arizona, and bids the suffering one good-night.

Interest, enjoyment and drowsiness come. Then sleep. Radio has acted as a soothing syrup, as a narcotic. It has taken the place of a sleeping potion.

Such a picture will be a common one in Beth Israel Hospital down on the East Side in a very few days.

Radio receiving sets are being installed beside every one of the 150 beds in the first known attempt to substitute harmless air music for narcotics.

The attempt is a recognition of the importance of radio to the medical science.

And the very poor of New York's teeming thousands, men and women and children who can't afford to pay for a doctor, will get the benefit of this newest of hospital innovations.

Louis J. Frank, superintendent of the institution, is keen on the idea. He said today:

"Radio is bound to reduce the use of narcotics, as we expect to operate it here. It will have the effect of taking the patients' minds off themselves. That will reduce nervousness, wakefulness and pain.

"Staring at blank walls during illness and convalescence is enough to drive one mad. Certainly it does not make for rapid recovery. Books help some to divert the mind, but music fixes the attention and interest and finally lulls one to sleep."

The sets will be powerful enough to catch music from any part of the country. And at no hour of the day or night will there be a dull radio moment, if the instruments are in tune. Mr. Frank said:

"The medical profession is getting further and further away from the use of drugs. There are all sorts of treatments for various diseases that do not include medicines. And we are sure that our experiment in the radio soothing syrup will be a decided step forward in the same direction."

Headpieces instead of horns will be used so that each patient may have his individual concert without disturbing any of the others. There are only wards in Beth Israel and a horn of the old phonograph variety placed among twenty or thirty persons would arrest the attention of them all, sometimes with unpleasant results.

Mr. Frank explained:

"There will really be two receiving sets by each bed," Mr. Frank said, "so that each patient may exercise choice over the selection of a programme."

Meanwhile, the present patients in the institution are hoping they will still be there when the first concert is caught. And hospitals over the country are wait-

Receiver Enclosed in Glass

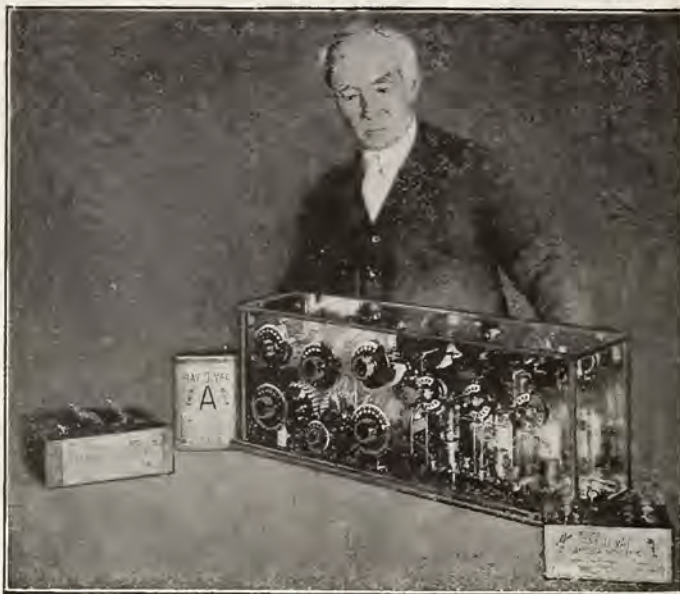

THE French Battery and Carbon Company has the distinction of having in its employ Chief Designer John Graves, who has conceived and built a radio receiving set of glass with two steps of audio frequency. The set operates with 3 WD-11 tubes on a Number 1261B Ray-O-Vac "A" Battery and 3 No. 2151 Ray-O-Vac "B" Batteries on the plate circuit.

This unusual set of glass is the eighth radio set Mr. Graves has built. Several years ago when radio was first coming into general use, Mr. Graves designed and built a set with the navy type loose coupler and a Remler Detector Panel. With this set only a very few stations were heard, chief among them being the University of Wisconsin Broadcasting station at Madison.

Following sets were fashioned with the other "hook-up" all of them being of two steps of audio frequency. Fellow workers at the French Battery and Carbon Company were fortunate in having Mr. Graves build sets for their use, all of them operating perfectly today.

The idea for the building of his glass

ing for news of the result of the experiment.

They are anxious to know what amount of narcotics will be eliminated.—[Corrinne Rich in New York American.

Vienna Station

The Marconi Company has taken over the Austrian Government radio station at Laaerburg, just outside of Vienna. This has necessitated negotiations between that company and representatives of the Naval Communication Service, regarding charges for traffic handled in the future for the Naval Communication Service. This station has formed since the war, a link in the naval communication service in Europe, from Paris to Constantinople.

set springs from Mr. Graves' association several years ago with a business in Milwaukee which made glass window display fixtures. "It was while attempting to cut down the expense of drilling holes through the plate glass used in making these fixtures," states Mr. Graves, "that I discovered a solution, through the use of which, I could drill these holes myself without danger of breaking the plates and at one-tenth the previous cost. With my solution, plate glass can be put into a lathe, if necessary and turned without danger of breakage. It holds the edge of the tool to the glass and makes a clean cut job."

There are 54 holes drilled through the glass used in the set varying in diameter from 3-16 to 3-8 of an inch. Each hole required from 10 to 12 minutes for drilling. Ordinary twist drills were used. The set is 26 inches long, 9 inches high and 6 inches deep.

With the set Mr. Graves reports having tuned into more than one hundred and fifty stations among them being the largest stations in the United States, Canada, Cuba and Porto Rico.—[Ray-O-Lite News.

Naval Operators

Very few naval officers assigned to communication duties are efficient radio operators, according to naval records. An officer assigned to such duty should consider it his first duty to learn at once the code, and after mastering it, a few hours listening in each day with an experienced operator, will soon enable him to operate. Only by this method can an officer acquire firsthand information regarding the efficiency of his operators in transmitting and in the observance of procedure, communication, officials say.

Send \$1.00 to Radio Age, 500 N. Dearborn St., Chicago, and receive this middle-west radio periodical for six months. Regular subscription price is \$2.50 a year.

What Does the Radio Public Want?

By WILLIAM H. EASTON

Westinghouse Electric & Manufacturing Company

IF THE radio audience could realize some of the problems that have to be solved by those who are engaged in preparing the programs, they would, I am sure, not only sympathize with them but would wonder how they preserve their sanity. No one before has ever had to entertain a million or so people every night; and consequently those who have undertaken this simple little task have had to stumble along as best they could learning as they go and profiting wherever possible by their mistakes. They are, however, exceedingly fortunate in having an audience that tells them frankly just what it thinks about their efforts; and with the hundreds of letters that reach them daily as a guide they have been able to work with some degree of certainty.

The first rule that the letters lay down is: Give the radio public infinite variety. If you were to open their mail some morning, the first letter would probably say, "I enjoyed your concert so much last night. That's right; give us more good music and do away with those execrable popular selections." Then the second letter would say, "For the love of Mike, cut out the Up-roar and give us good old American Jazz." Letter number three would read as follows: "Prof. Simpkins' address on the Color of Cats was the most interesting speech I ever listened to"; and letter number four would state, "Why do you afflict your audience with such stupid stuff as the talk on cats? I hung up my receiver in disgust."

With testimony like this it is quite evident that it is very difficult to satisfy everybody all the time. The only thing to be done, is to draw from the entire field of music, literature, science, politics, culture, hygiene, and religion, and thus please everyone at least part of the time. Consequently, those who do not like jazz music must bear in mind that many will listen to nothing else; while those who do not like speeches must remember that a very large number of radio listeners are isolated or are invalids, and absolutely depend upon radio for their contact with the outside world.

The second point that the letters prove is, there must be constant improvement in broadcasting both technically and artistically. No station can maintain its programs on a dead level and retain the interest

of its audience. The complaints soon begin to come in. Curiously enough, they are all to the effect that the programs are getting so poor. This is not the case. They are just as good as ever; but the taste of the audience has improved. It is for this reason that KDKA is experimenting so constantly in every direction. Its engineers are incessantly striving for better tone reproduction and for the elimination of unpleasant noises. Its program staff is incessantly working for better artistic effects and for entirely new features. They began with the phonograph; then introduced artists and speakers in person; then went outside of the studio for church services, important meetings, symphony concerts, operas, and sporting events; and recently established an orchestra so that incidental music could be rendered in the best possible manner. Thus, in accordance with the well-known

formula, "Every day in every way we are getting better and better." But no one realizes more fully how much more must be done in order to continue to preserve the good opinion of the radio audience.

The third important fact that develops from the correspondence is, interference must be eliminated. Not only must the audience be able to hear this station clearly and distinctly whenever they wish to hear it, but they must also be at perfect liberty to eliminate its signals and receive equally clearly the program to some other station that may, for the moment, please them better. This is their most serious problem at present.

The great increase in the number of stations has filled the ether with chaos and confusion and if this is not remedied broadcasting will die out. The government, the radio engineers, and those broadcasting stations that are interested in radio for

How to Get the Most Out of One Tube



Duo-Reflex simplicity assures neat, compact, cabinet installation. Detailed blue prints are on sale by dealers at 25c per set



Erla radio frequency transformers maintain unequaled amplification over a wave-band of 200 to 900 meters. AB 1, 2, 3, \$4. Reflex, \$5
Dealers and Jobbers—Erla leadership in research paves the way to increased sales. Jobbers—write for our liberal terms and discounts

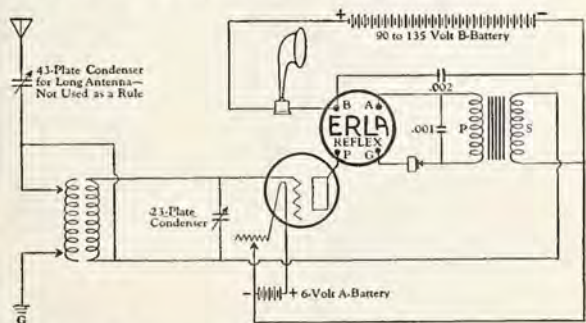

Use Duo-Reflex Hook-Up and Erla Transformers

You will never know the full range and power of a single tube until you have operated Duo-Reflex, the most powerful single-tube circuit ever built.

Under conditions at all favorable, a wide compass of stations is brought in through a loud speaker, and headphones extend the range from coast to coast.

Especially designed for Duo-Reflex, and the major essential of its power is the Erla radio frequency reflex transformer, one of the greatest improvements in years.

Complete instructions for building Duo-Reflex are given in Erla Bulletin No. 13, obtainable gratis from leading radio dealers. Or write us, giving your dealer's name.

ERLA Electrical Research Laboratories
Dept. M 2515 Michigan Ave., Chicago

its own sake, and not for selfish reasons, are struggling with it valiantly. Though the situation may at times look hopeless, one should not forget that worse troubles than this have been smoothed out.

Broadcasting is only an infant. If it develops as rapidly within the next two years as it has in the past two (and there is every reason to believe that it will) interference will disappear; trivial programs will make way for those of real interest and importance; and it will be possible to hear not only the large American stations, clearly and distinctly, almost anywhere in the United States, but stations in London, Paris and Rome as well.

Cornered by Radio

Radio has invaded the country grocery store. Round-the-stove conferences, once devoted to the discussion of national political issues, have been suspended in favor of radio broadcast entertainment, addresses and sermons.

A sermon delivered by the Rev. Dr. Philip Frick, pastor of the First Methodist Church in Schenectady, N. Y., was broadcast by WGY, the General Electric Company station. Dr. Frick received the following letter from "Bill" Davenport, of Hillside Farm, Jefferson, New Hampshire:

"My Dear Sir:

"You will see by the heading of this letter, I am 'way up in the White Hills, right under Mount Washington. Today, Sunday, I had occasion to go to the store of F. O. Giddon and while there I heard a sermon preached by you, which I enjoyed very much. In fact it is the first one I have heard in thirty-five years. So you will see I am not much of a churchgoer, and to think you, away off in New York, should be the first one to catch me. The sermon was very distinct and the singing was fine. In our little town we have three churches, but there are quite a few of us old hardshells who rather go to the store and discuss whatever has transpired through the week.

"I just wish you could have looked in on the bunch while you were preaching. We were all held spellbound. You could have heard a pin drop anywhere in the room.

"Hope you will not think we all are heathens up here in the mountains. I should be very glad, if you ever came this way, to have you for my guest for a few days. Hoping that I may be able to hear another one of your sermons, I remain—"

Ziegemeier Transferred

Rear Admiral Henry J. Zeigemeier, Director of Naval Communications, and one of the foremost experts of the navy, has been detailed to command the Norfolk navy yard. His successor as Director of Naval Communications has not been named, but it is stated that Commander D. C. Bingham, Assistant Director, will be acting chief.

Uncle Joe Cannon a Radio Fan



Uncle Joe Cannon, listening to his first concert on his new radio set given to him by the Westinghouse Company on his 87th birthday.

OUT of politics forever and back to the routine of his old home town, Uncle Joe Cannon, Speaker in the House of Representatives for many years, will keep in touch with the outside world by means of radio and learn what the law makers at Washington are doing. He became a fan when the Westinghouse Electric & Manufacturing Company presented him with a complete radio set on the occasion of his eighty-seventh birthday which was celebrated in Danville, Ill., on May 7. The outfit has been installed in his home and he is already a constant listener to the programs broadcasted all over the country. After the set was installed and Uncle Joe was instructed on its operation he immediately settled down to enjoy its use.

Mr. Cannon listened for a time and then said: "There's an effort on the part of someone to talk and an effort on the part of my ears to hear, but nothing else."

He was shown how to make finer adjustments, caught voices then music, grand opera.

"That's better," he said, crossing his legs settling more comfortably in his chair and enjoying it for some time. He gave every indication of becoming a real radio fan.

"That woman has a good voice, yes, a remarkable voice hasn't she?" he inquired of a group of newspaper men, camera men and members of his family gathered near him. Then he smiled as he realized that none but he had heard.

"What was it, grand opera?" inquired one of the newspaper men.

"—es," replied Mr. Cannon, "I think that's what you would call it. It was very good."

Although the radio set was only one of a number of gifts received by Uncle Joe, he seemed to take the most pride in his radio set.

The set was installed on his birthday by C. E. Butler radio service manager of the Westinghouse Chicago office who made a special trip to Danville to see that the set was properly erected.

Radio Letters from Latvia

The Latvian Main Post and Telegraph Administration announces that radio letters to the United States may be filed at all Latvian telegraph offices. The letters will be mailed to Berlin, whence they will be transmitted by wireless to New York, and from there to the addressees by post.

The letters must contain text in English, French or German.

The charges for radio letters are 35 centimes per word, plus 1 lat (equal to 1 French franc) ground fee per wire.

Prices Too High

American radio manufacturers ask too much for their radio apparatus and materials to secure the Dutch trade, according to Consul Mahin, at Amsterdam. Competition from other countries, especially Germany, is reported to prohibit Dutch interests doing business with American exporters although the demand for radio telephone sets is good in Holland.

Wireless Phone, Ship to Shore

The United Steamship Company of Copenhagen, Denmark, plans to install wireless telephone equipment on all boats plying between Copenhagen and the provincial harbors for the traveling public's convenience. Travelers will be able to secure direct communication, through the land telephone service, with their own homes or offices, similar to the service planned for the U. S. Ship LEVIATHAN.

Canary Islands Considering Wireless

Vice Consul Phelan, in the Canary Islands, reports active discussion in the Cabildo Insular de Tenerife of a proposal to establish in the near future wireless telephone stations at the various islands of the Archipelago. The present cable service between the islands has been very inefficient and has given rise to the suggestion of using wireless telephony.

Radio Pays a Debt

Radio has paid part of the debt which it owes to the genius of E. F. W. Alexanderson, chief engineer of the Radio Corporation of America and a consulting engineer of the General Electric Company.

Monday, April 30, Verner, six-year-old son of Dr. Alexanderson, was lured from his home by the promise of a gift of rabbits, and kidnapped. The police had practically no clues on which to work; in spite of the active work and close cooperation of newspapers, police and radio broadcasting stations, the case appeared to be at a standstill and the whereabouts of the boy remained a mystery for three days.

Bert Jarvis, of Theresa, a Jefferson County, N. Y., village of a thousand inhabitants, listening in Monday night on his homemade radio set, heard WGY, the Schenectady radio broadcasting station of the General Electric Company, announce the kidnapping. Jarvis rents boats to fishermen and acts as caretaker for numerous summer cottages in the vicinity of Theresa. A few days before the kidnapping he had rented an isolated cottage to a man who was bringing his family up from the city for the season.

After hearing the radio description of missing boy and kidnapper, Jarvis' suspicions were aroused. Tuesday, he met the owner of the cottage and asked him who had taken possession. The owner explained that it was only an old woman, a little boy and one man.

It so happened that the man, when renting the cottage, had said he was going to bring his daughter. Jarvis' suspicions grew, and Wednesday he decided to ride out to the vicinity of the cottage in his motorboat. He stopped at the cottage and asked the old woman who came to the door for a drink of water. He entered the house and saw a child on the bed. Jarvis returned to the cottage later and asked for candle-wicking for his motor. On this visit he waved to the boy and the boy waved at him.

Thursday morning Jarvis saw a photograph of the kidnapped child in the Syracuse Post Standard and this picture tallied with the boy of the cottage. Now sure of his ground, he reported to the deputy sheriff and a few hours later Verner Alexanderson talked over the long distance telephone to his father and mother.

The successful use of radio in the Alexanderson case has convincingly proved the value of radio broadcasting as a publicity factor, when far-reaching results are desired in a short time. WGY announced the kidnapping within two hours after it had been reported to the police. Other broadcasting stations joined their voices to the voice of WGY, and the story, with descriptions of the missing boy and kidnapper, went out over the entire country. Radio fans everywhere were enlisted in the search. The newspapers kept them posted on the progress of the case and also furnished them with pictures of the boy. Through Hudson Maxim, the members of the Amateur Radio Relay League took up the case and hundreds of spark sets flashed the story through the air.

Dr. Alexanderson made a personal appeal from the Schenectady broadcasting station and after the boy had been found he again addressed the radio audience, thanking all for their interest, sympathy and assistance. He placed special emphasis on the cooperation of press and police.

Dr. Alexanderson has done much for radio, but the engineer feels that radio has more than repaid him for his work, for it has restored happiness to his home.

At Goteborg Fair

Radio will have an important place in the International Aero Exhibition at Goteborg, Sweden, during July and August, according to dispatches from Consul Sholes to the Department of Commerce. A special radio section is under preparation, and several foreign and American firms are expected to exhibit apparatus, especially radio sets suitable for inter-plane and plane to ground communication.

A feature of unusual interest will be the daily receipt of news by radio from the United States for the American visitors at the exposition. Through the cooperation of a Swedish-American News Association and the Naval Communication Service, NAA will broadcast daily five hundred words of home news.

Moving Trains

Germany recently had a demonstration of wireless telephonic communication between a moving train and ordinary receiving and transmitting stations, according to Consul Richardson, at Berlin. Messages were exchanged between the President and officials of the government in Berlin and other officials on a train, moving at thirty miles an hour, half-way between Berlin and Hamburg, by means of the Huth system. This system is a combination of wireless and wire transmission. The sending apparatus was installed in a compartment on the train and the antenna rigged over the tops of two cars. The line telegraph wires along the track are said to have picked up the messages and transmitted them to Berlin, where the line was connected with a receiving set.

This "United"

Audio Frequency Amplifying Transformer

Is a little "gem" of radio engineering—magnetically shielded, Ratio 5 to 1—a wonder-worker in producing loud, clear-toned signals, from any distance. At your dealer's. \$4.50



"United" variable condensers have a new vernier dial assembly, original with us, that makes fine tuning a joy.



43 plate.....	\$6.50	5 plate.....	\$5.00
23 plate.....	6.00	3 plate.....	4.75
11 plate.....	5.50		Postpaid

Vernier alone can be attached to any plate condenser by drilling 1 hole, \$2.50

Show this ad to your Dealer and ask him to supply your needs at the above prices. If he cannot do so, remit to us direct, under our money-back guarantee and give us name and address of Dealer you wish to favor.

UNITED MFG. AND DISTRIBUTING CO.

9705 Cottage Grove Ave., CHICAGO, ILL.

NEW YORK OFFICE
50 Church St., New York, N. Y.

SAN FRANCISCO OFFICE
700 Mission St., San Francisco, Cal.

LEARN RADIO

Here's your opportunity. Radio needs you. Win success in this fascinating field. Trained men in demand at highest salaries. Learn at home, in your spare time.

Be a Radio Expert

I will train you, quickly and easily, to design, construct, install, operate, repair, maintain, and sell all forms of Radio apparatus. My new methods are the most successful in existence. Learn to earn

\$1,800 to \$10,000 a Year

FREE Wonderful, home-construction, tube receiving set, of latest design. Write for "Radio Facts" free. Engineer Mohaupt.

American Electrical Association
Dept. 000 4513 Ravenswood Ave., Chicago

Fooling the Broadcaster?

SOME snappy comments on the efforts of the music publishers and composers to make it appear that they really and truly believe broadcasting hurts the sale of their music are contained in a recent issue of "Gossip on The Rilato," of New York. The article follows:

"The broadcasters certainly are a fine bunch of dumbbells. Here they are fightin' the society of composers, authors and publishers because the society is tryin' to pick some berries where berries ain't growin'. But the publishers are makin' boobs out o' them. They can give them broadcasters the best cards in the deck and still take the money. Now, this is the way it works:

"The broadcasters won't pay for singers and orchestras, so they go aroun' gettin' the kind of birds that performs for nothin' and think they're gettin' away with it. These publishers ain't asleep; they got their ears to the ground all the time. When a big broadcaster with a fat station wants a pretty, sweet-voiced singer to sing for nothin', who do you think appears on the scene? Why, likely as not some good lookin' outfit from the professional department of one of the big combinations. Does he say he is from a publisher? He does not. And what do we find this free service artist singin'? Why, the numbers that the publishers are pluggin'.

"Or maybe the orchestra leader says what dance music he's goin' to play. He don't hear them when the radios want their music shot out. And he's got a million reasons why he's goin' to play the music of the publishers' combination. The public wants it, etc., etc., he says. Now you don't need no two guesses what the real reason is.

"Take this 'banana' song. You know the one I mean, called 'Yes, we have no bananas.' It's one of them hit-and-get-away things that must be plugged in a hurry. What did we find all last week, and the week before? The only thing you could get out of the air was 'bananas.'

"It is certainly a great game, these publishers claimin' that radio don't popularize music, and then findin' an openin' in the broadcasters fightin' program and puttin' their own things over at the expense of the broadcasters, and then not knowin' it. These birds know that radio can work up a hit quicker than all their pluggers put together. You are goin' to see the publishers fallin' one at a time. They will pay to have their things plugged through the air before they get through.

"It makes me laugh to see the way they work. First they are goin' to make the broadcasters pay. Yes, they are—not. Try and get it. Then they offer licenses free. And they sneak in their professionals on radio programs. Well, it is only a step to come out in the open and ask to have their stuff plugged over the air, and I bet my last

dollar that if these broadcasters don't fall asleep they will be collectin' from the publishers instead of payin' them.

"Why, even now two of the big ones are tellin' their professional department to get ready; that they got to go aroun' the country puttin' on programs for broadcasters. Of course they will make it look like they are doin' the radio men a big favor. It's a sacrifice bunt they're goin' to try to turn into a two-bagger. It's fun to watch the plugs. They've bluffed a few radios. But the wise guys ain't bein' bluffed a-tall, a-tall. They make bums of song writers but I'm bettin' my last bean they ain't goin' to make no bum out of a radio."

Fans Hit a Snag

Many radio broadcasting fans have been experiencing difficulty in tuning in stations since the reallocation of wave lengths on May 15.

It is not surprising that trouble of this kind has arisen among many of the listeners, who had become quite proficient in tuning to the old wave lengths used by the various stations. In some instances, the difficulty lies in the receiving sets, with which the trouble is being experienced, and many of them will have to have additional wire added to the tuning coils in order to reach the longer waves now being used by some of the stations.

In spite of the difficulty that some are having, it is certain that after the radio fans have become accustomed to tuning for the new wave lengths, the service will be more satisfactory than ever before.

Some of the stations using higher wave lengths are: WOC, Davenport, Iowa; KIF, Los Angeles, Calif.; KGW, Portland, Ore.; KPO, San Francisco, Calif.; KFDB, San Francisco, Calif.; WCX, Detroit, Mich.; WGM, Atlanta, Ga.; WHB, Kansas City, Mo.; WIP, Philadelphia, Pa.; WJZ, New York City; WMC, Memphis, Tenn.; WBAP, Ft. Worth, Texas; WCAE, Pittsburgh, Pa.; WDAF, Kansas City, Mo.; WEA, New York City; WFAA, Dallas, Texas; WJAZ, Chicago, Ill.; WLAG, Minneapolis, Minn.; WMAQ, Chicago, Ill.; WSB, Atlanta, Ga., and WWV, Detroit, Michigan.

Unique Exhibit

"Taking Broadway with him," was well illustrated by a recent exhibit which Lyon and Healy had at the Outdoor and Sportsman show at the Coliseum, in Chicago, during May.

The Chicago music house used an elaborate setting, which was a reproduction of a bit of woodland scenery. The effect was very artistically worked out.

An interesting feature of the display was a twelve-foot waterfall. This fed the miniature stream illustrated.

The dummy of the sportsman attracted favorable comment from men who know the joys of fishing.

The exhibit was given over to radio. Lyon and Healy displayed its new portable outfit and got over very effectively its sales message.

592 Broadcasters

Washington, D. C.—Radio broadcasting stations total 592, according to a recent Department of Commerce survey. Of this number, 113 are class A stations, thirty-six high-powered class B stations, 1 KDKA, designated as a broadcasting development station, and the balance, 442, class C, operating on 360 meters.

Many old stations grouped temporarily as class C and directed to operate only on 360 meters, have been reclassified as A stations and assigned special district waves. There remain 442 in this class today, either awaiting new wave lengths or satisfied to continue on 360 meters. New stations, however, are still coming in, about thirty being added in the last thirty days, while twenty dropped out.

During the week ending May 28, four new A stations were licensed; one each in Pennsylvania and South Dakota, and two in Colorado. Fourteen C stations were transferred from class C during the week ending May 26.

Here's Evidence

The Radio Age:

Am just in receipt of the June number of Radio Age. I notice with particular interest the article in "Thought Waves from the Editorial Tower" an article regarding Mr. Wendell Hall, and also the expression of The American Society of Composers, Authors and Publishers, in that radio does not create a demand for the songs and musical compositions.

The writer happened to have a few of his friends in one evening, perhaps two or three months ago and we were listening to a very nice concert from KYW, Chicago. That evening we heard Mr. Hall sing his "Mellow Moon," and I believe one other piece; I don't remember the name. However, that was the first time any of us had heard that particular piece, and I personally know that it caused the sale of three Edison records and five copies for the piano, just from our own home that evening. It seems to me that this is conclusive proof that the radio absolutely sold every one of these numbers. (It might have been Mr. Hall's voice, however, as it was just as good as if he had been in our own home.) Any way the sales were made through radio broadcast

Yours truly,
ALLEN TOOMEY,
Spearfish, S. Dak.

Mr. Haws to Europe

R. Calvert Haws, Vice President and General Manager of the Shuman-Haws Advertising Company, Chicago, is visiting England and the continent in order, primarily, to make a firsthand study of European radio industries and markets.

While abroad, he will secure European connections for radio clients of his agency and will also seek to arrange for American outlets for such meritorious European radio apparatus as he may encounter.

Complete Corrected List of U. S. and Canadian Broadcasting Stations

Complete Each Issue

THE list of broadcasting stations on these pages is brought up to date each month by additions of new stations and deletion of those which have suspended operation. The list is the product of a vast volume of correspondence and its completeness is due in large measure to the assistance of our special news service in Washington, D. C. Suggestions, corrections and additional data will be welcomed from readers. Broadcasters: Send in your program schedules.

Wave lengths assigned to stations by the Department of Commerce, so far as the announced, will be found in a table on another page.

- IXAD, Pawtucket, R. I. 1000 miles; Special license experimental; Standard Radio & Electric Co.
- KDKA, E. Pittsburg, Pa.; Class B station Westinghouse Elec. & Mfg Co.
- KDOW, Steamship America, New York.
- KDPM, Cleveland, Ohio; Westinghouse Elec. & Mfg. Co.
- KDYL, Salt Lake City, Utah; news music, entertainment, Telegram Publishing Co.
- KOYM, San Diego, Cal.; Savoy Theatre; 252 meters 100 watts
- KDYQ, Portland, Ore.; Oregon Inst. Technology.
- KDYS, Great Falls, Mont.; Class B, Great Falls Tribune.
- KDYS, Phoenix, Arizona; Smith Hedges & Co.
- KOYX, Honolulu, T. H.; 12:15 to 1:15 p. m., stock reports and weather; 6:30 to 7:30 p. m., music, lectures; Sunday, 11 a. m. to 12:30 p. m., sermons; Honolulu Star-Bulletin, Ltd.
- KDZB, Bakersfield, Calif.; Frank E. Selfert.
- KDZE, Seattle, Wash.; Rhodes Co.
- KDZF, Los Angeles, Calif.; Automobile Club of Southern California.
- KDZG, San Francisco, Calif.; Cyrus Pierce & Co.
- KDZI, Wenatchee, Wash.; Electric Supply Co.
- KDZK, Reno, Nev., Wednesday 8 to 9 p. m.; Friday 8 to 9 p. m. Musical and news features; Nevada State Journal, Nevada Machinery & Electric Co.
- KDZZ, Denver, Colo. Pyle & Nichols, 1247 Broadway.
- KDZR, Bellingham, Wash. 281 meters, 50 watts; Bellingham Pub. Co.
- KDZX, San Francisco, Calif.; Glad Tidings Tabernacle.
- KFAD, Phoenix Ariz.; Class B, McArthur Bros. Mercantile Co.
- KFAE, Pullman, Wash.; State College of Washington.
- KFAF, Denver, Colorado; George S. Walker, Western Radio Corporation; musical programs, news items, etc., daily except Tuesday and Sunday, 8 to 9 p. m.; mountain standard time.
- KFAJ, Boulder, Colo.; University of Colorado.
- KFAN, Moscow, Idaho; Electric Shop.
- KFAP, Butte, Mont.; Standard Pub. Co.
- KFAQ, San Jose, Calif.; City of San Jose.
- KFAR, Hollywood, Calif.; Hollywood Light & Service Co.
- KFAT, Eugene, Ore. Monday, Wednesday and Saturday 8 to 9 p. m. Music; Sunday 8:30 to 9:15 Church Services; Pacific Radio Co.
- KFAU, Boise, Idaho; Class B, Boise High School.
- KFAV, Venice, Calif.; Abbott Kinney Co.
- KFAW, Santa Anna, Calif.; Class B, Radio Den.
- KFBY, Central Point, Ore.; W. J. Virgin Milling Co.
- KFBB, Bayre, Mont.; P. A. Buttrey & Co.
- KFBC, San Diego, Calif.; W. K. Arbild.
- KFBD, Hanford, Calif.; California Radio Lab.
- KFBE, San Louis Obispo, Calif.; R. H. Horn.
- KFBG, Tacoma, Wash.; First Presbyterian Church.
- KFBH, Marshfield, Ore.; Thomas Musical Co.
- KFBK, Sacramento, Calif.; 3.0 m.; daily, 8 to 4 p. m. and 6 to 6:30 p. m.; Sunday and Thursday 8 to 9 p. m.; Kimball-Union Co. and Sacramento Union.
- KFBL, Everett, Wash.; Leese Bros.
- KFBU, Laramie, Wyo.; N. S. Thomas.
- KFBC, Phoenix, Ariz.; Nielson Radio Supply Co.
- KFCO, Salem, Ore.; F. S. Hartin.
- KFCF, Walla Walla, Wash.; Frank A. Moore.
- KFCM, Billings, Mont.; Elec. Service Station.
- KFCN, Colorado Springs, Colo.; Colorado Springs Radio Co.
- KFCL, Los Angeles, Calif.; Los Angeles Union Stock Yards.
- KFCM, Richmond, Calif.; Richmond Radio Shop.
- KFCQ, Casper, Wyo.; Motor Service Station.
- KFCP, Ogden, Utah, Ralph W. Flyzars.
- KFCY, Houston, Tex., Fred Mahaffey, Jr.
- KFCZ, Le Mars, Ia.; Western Union College.
- KFGZ, Omaha, Neb.; Omaha Central High School.
- KFDA, Baker, Ore.; Adler's Music Store.
- KFDB, San Francisco, Calif.; Mercantile Trust Co.
- KFDD, Spokane, Wash.; Radio Supply Co.; 283 meters; 10 watts.
- KFDD, Boise, Idaho; St. Michael's Cathedral.
- KFDD, Bozeman, Mont.; Everett H. Cutting.
- KFDP, Des Moines, Ia.; Hawkeye Radio & Supply Co.
- KFDS, San Francisco, Calif.; John D. McKee.
- KFDU, Lincoln, Neb.; Nebraska Radio & Elec. Co.; 240 meters; 20 watts.
- KFDV, Fayetteville, Ark.; Gilbrech & Stinson.
- KFDY, Brookings, S. D.; South Dakota State College of Agriculture and Mechanical Arts.
- KFDL, Denver, Colo.; Knight Campbell Music Co.
- KFDI, Corvallis, Ore.; Oregon Art. College.
- KFDD, Spokane, Wash.; Radio Supply Co.
- KFDF, Casper, Wyo.; Wyoming Radio Corp.
- KFDR, York, Nebraska; Bullock's Hardware & Sporting Goods.
- KFDX, Shreveport, La.; First Baptist Church.
- KFDZ, Minneapolis, Minn.; Harry O. Iverson.
- KFEA, Taft, Calif.; City of Taft.
- KFEB, Portland, Ore.; Mader & Frank Co.
- KFEJ, Tacoma, Wash.; Guy Grasson.
- KFEL, Fenner, Colo.; Winner Radio Corp.
- KFEP, Denver, Colo.; Radio Equipment Co.
- KFEQ, Oak Nebraska; J. L. Scroggin.
- KFEQ, Oak, Nebraska; J. L. Scroggin.
- KFER, Ft. Dodge, Iowa; 251 meters, 10 watts; Auto Electric Service Co.
- KFEV, Douglas, Wyo.; Radio Elec. Shop; 243 meters; 100 watts.
- KFEY, Minneapolis, Minn.; 261 meters, 100 watts Augsburg Seminary.
- KFEY, Kellogg, Idaho; Bunker Hill & Sullivan Mining & Construction Co.
- KFFZ, Dallas, Texas; 226 meters, 20 watts; A. G. Barnes Amusement Co.
- KFEZ, St. Louis, Mo.; American Society of Mechanical Engineers.
- KFFA, San Diego, Calif.; Dr. R. C. Shelton.
- KFFB, Pendleton, Ore.; Eastern Oregon Radio Co.
- KFFD, Hillsboro, Oregon; Dr. E. H. Smith.
- KFFP, Moberly, Missouri; First Baptist Church.
- KFFQ, Colorado Springs, Colo.; Markshoff Motor Co.
- KFFR, Sparks, Nev.; Jim Kirk.
- KFFV, Lamoni, Iowa; Grace Land Collers.
- KFFX, Omaha, Neb.; 278 meters, 250 watts; The McGraw Co.
- KFFY, Alexandria, La.; 276 meters; 100 watts; Pinous & Murphy Inc.
- KFFB, Pueblo, Co.; Lowenthal Bros.
- KFFG, Baton Rouge, La.; 244 meters, 100 watts; Louisiana State University.
- KFFD, Chickasha, Okla.; 248 meters, 20 watts; Chickasha Radio & Elec. Co.
- KFFG, Mt. Vernon, Wash.; Buchanan, Stevens & Co.
- KFFH, Stanford Univ., Calif.
- KFFI, St. Louis, Mo.; 266 meters, 100 watts; Nat'l Guards Missouri 138 Infantry.
- KFFL, Arlington, Oregon; Arlington Garage.
- KFFP, Cheney, Kansas; 229 meters, 10 watts; Cheney Radio Company.
- KFFQ, Boone, Iowa; 226 meters, 20 watts; Cray Hardware Co.
- KFFV, Ulca, Nebraska; 224 meters, 10 watts; Heddred Radio Supply Co.
- KFFX, Orange, Texas; 250 meters; 500 watts; First Presbyterian Church.
- KFFY, Baudette, Minn.; 224 meters, 15 watts; Gjelhayg's Radio Shop.
- KFFZ, Berrien Springs, Mich.; 268 meters, 10 watts; Emmanuel Missionary College.
- KFHA, Gunnison, Colo.; Colorado State Normal School.
- KFHB, Hood River, Oregon; P. L. Boardwell.
- KFHD, St. Joseph, Mo.; 226 meters, 10 watts; Utz Electric Co.
- KFHF, Shreveport, La. 266 meters, 150 watts; Central Christian Church.
- KFHR, Seattle, Wash.; Star Elect & Radio Co; 270 meters; 100 watts.
- KFHN, West Bay, Wash.; Ambrose McCue.
- KFHI, Wichita, Kansas; 224 meters, 30 watts; Charles V. Dixon.
- KFHL, Santa Barbara, Calif.; Fallon Co.
- KFHL, Oskaloosa, Ia.; 227 meters, 10 watts; Penn College.
- KFHP, Kearney, Nebr.; Radio Bug Products Co; 246 meters; 10 watts.
- KFID, Toia, Kansas, 246 meters, 20 watts; Ross Arbuckle's Garage.
- KFIQ, Yakima, Wash.; 224 meters, 50 watts; Yakima Valley Radio Broadcasting Association.
- KFI, Los Angeles, Calif.; radius covers entire U. S. and Canada; Daily, 6:45 to 11 p. m., Sunday 10 to 11 a. m., 4 to 4:30 and 8 to 11 p. m.; entertainment and educational features; station operates three remote control stations; Earle C. Anthony, Inc.
- KFIB, St. Louis, Mo.; 214 meters, 10 watts; Franklin W. Jenkins.
- KFIF, Portland, Ore.; Benson Tech. Student Body.
- KFIG, Denver, Colorado; 224 meters, 15 watts; Philip Laskowitz.
- KFIJ, Platte, S. D.; Sidney L. Thoreau; 236 meters; 5 watts.
- KFIK, Gladbrook, Ia.; Gladbrook Electric Co; 234 meters; 20 watts.
- KFID, Spokane, Wash.; North Central High School; 252 meters; 50 watts.
- KFJD, Greeley, Colo.; Weld County Printing & Publishing Co; 236 meters; 100 watts.
- KFKH, Denver Park Amusement Co; Lakeside, Colo; 226 meters, 10 watts.
- KFU, Gridley, Calif.; The Precision Shop.
- KFZ, Spokane, Wash.; Doerr-Mitchell Elec. Co.
- KGG, Tacoma, Wash., Sunday; 5 to 7:30; Daily; 7 to 9 p. m. (except Thursday) News, Sport bulletins, lectures, entertainment, weather, tide tables, bedtime stories, time, etc.; Tacoma Daily Ledger station operated by the William A. Mullins Electric Co.
- KGG, Portland, Ore.; Hallock & Watson Radio Service.
- KGN, Portland, Ore.; Northwestern Radio Mfg. Co.
- KGD, Altadena, Cal. 2500 miles; every Saturday 8 to 9:30 p. m. Musical program;
- KGU, Honolulu, Hawaii, Waikiki Beach, Marlon A. Mulrony; Honolulu Advertiser
- KGV, Portland, Ore.; Oregonian Pub. Co.
- KGY, Lacey, Wash.; St. Martin's College, (Rev. S. Ruth).
- KHI, Los Angeles, Calif.; Daily except Sunday; 12:30 p. m. to 1:15 p. m. news and concerts; 7 to 7:30 p. m. Children's Half Hour; 8 to 9:30 p. m. De Luxe program of music, news and educational features; Sunday; 10 to 11 a. m. Scripture reading, sermon, prayer and sacred musical program; Pacific time: Times-Mirror company.
- KHJ, Seattle, Wash.; Louie Wasmer.
- KIJ, Sunnyside, Calif.; The Radio Shop.
- KJQ, Stockton, Calif.; C. O. Gould.
- KIS, Los Angeles, Calif.; Bible Inst. of Los Angeles.
- KL, Pasadena, Calif.; J. J. Dunn & Co.
- KFDH, Tucson, Ariz.; Univ. of Arizona.
- KLS, Oakland, Calif.; Warner Bros.
- KLX, Oakland, Calif.; Tribune Pub. Co.
- KLZ, Denver, Colo.; Class B, 485, Reynolds Radio Co.
- KMAZ, Macon, Ga., Mercer University.
- KMG, Reedley, Calif.; Lindsay-Wetherill Co.
- KMJ, Fresno, Calif. Max. 2576 Miles; Musical program, San Joaquin Light & Power Corp.
- KMO, Tacoma, Wash., Lovs Electric Co.; Tacoma Times.
- KNI, Eureka, Calif.; T. W. Smith.
- KNJ, Roswell, New Mexico; 1000 miles; Every evening at 8; news, weather reports, stock market, concerts and sermons; Roswell Public Service Co.
- KNN, Los Angeles, Calif.; Bullocks.
- KNT, Aberdeen, Wash.; North Coast Products Co.
- KNV, Los Angeles, Calif.; Radio Supply Co.
- KNW, Los Angeles, Calif.; Electric Lighting Supply Co.
- KOA, Denver, Colo.; T. M. C. A.
- KOB, State College, N. Mex.; time signals and weather reports 12 noon and 10 p. m. mountain time; music and lectures Monday, Wednesday and Friday, 7:30 to 8:30 p. m.; New Mexico College of Agriculture and Mechanical Arts.
- KOE, Spokane, Wash.; Spokane Chronicle.
- KOF, Detroit, Mich.; Detroit Police Dept.
- KOG, Modesto, Calif.; Modesto Evening News.
- KPD, San Francisco, Calif.; Hale Bros.
- KQI, Berkeley, Calif., Unit of California.
- KQP, Hood River, Oregon; Apple City Radio Club.
- KQV, Pittsburgh, Pa., Doubleday-Hill Elec. Co.
- KRW, San Jose, Calif., Chas. D. Herrold.
- KRE, Berkeley, Calif., Maxwell Electric Co.
- KSC, San Jose, Calif., O. A. Hale & Co.
- KSD, St. Louis, Mo.; 1700 miles; grain, brostock, cotton, New York stocks, poultry and butter market, metal market, official weather and news at 9:40, 10:40, 11:40, 12:40, 1:40, 2:40 and 4 p. m.; 8 p. m. 400 meters, musical and other features; Pulitzer Publishing Co., St. Louis Post Dispatch.
- KSL, San Francisco, Calif., The Emporium.
- KSS, Long Beach, Calif., Prest & Dean Radio Research Lab.
- KSU, Wenatchee, Wash.
- KTW, Seattle, Wash., First Presbyterian Church.
- KUO, San Francisco, Calif., Examiner Printing Co., San Fran. Examiner.
- KUS, Los Angeles, Cal. 500 miles; setting up exercises daily, 7 to 7:30 a. m. and 12:00 noon to 12:30 p. m.; concert, 65 volumes, 8 to 6:45 p. m., Wednesdays and Fridays; City Dye Works.
- KUV, Del Monte Calif., Coast Radio Co.
- KWB, Stockton, Cal. Daily Market reports, music and news 4 to 5 p. m.; Music, 3 to 3 p. m. Sunday; Tuesdays and Fridays, music, 8 to 9 p. m. Portable Wireless Telephone Co.
- KWH, Los Angeles, Calif., Los Angeles Examiner.
- KXD, Modesto, Calif., Herald Publishing Co.
- KYQ, Honolulu, T. H., The Electric Shop.
- KYW, Chicago, Ill.; Westinghouse Elec. & Mfg. Co. 345 meters.
- KZM, Oakland, Calif., Western Radio Inst.; Preston D. Allen.
- KZL, Salt Lake City, Utah, The Deseret News.
- KZV, Wenatchee, Wash., Wenatchee Battery & Motor Co.
- NDF, Anacostia, D. C., U. S. Navy Dept.
- PWX, Havana, Cuba, Cuban Telephone Co.
- WABD, Dayton, Ohio; 286 meters, 100 watts; Parker High School.
- WAI, Dayton, Ohio, McCook Field, U. S. Army.
- WAAB, New Orleans, La., Valdemar Jensen.
- WAAC, New Orleans, La., Tulane Univ.
- WAAD, Cincinnati, Ohio, Ohio Mechanics Inst.
- WAAP, Chicago, Ill., Chicago Daily Drivers Journal.
- WAAS, St. Louis, Mo., St. Louis Chamber of Commerce.
- WAAT, St. Paul, Minn., Commonwealth Electric Co.
- WAAB, Milwaukee, Wis., Gimbel Bros.
- WAAL, Minneapolis, Minn., Minnesota Tribune Co. & Anderson-Beamish Co.

(Continued on next page.)

Complete Corrected List of U. S. and Canadian Broadcasting Stations

- WAAM, Newark, N. J. 300 miles; musical and code, every week day 11 to 11:55 a. m. & 4 to 5 p. m.; Wednesday evenings 8 to 9; I. B. Nelson Company.
- WAAN, Columbia, Mo., Univ. of Missouri.
- WAAP, Wichita, Kans., United Elec. Co.; Otto W. Taylor.
- WAQA, Greenwich, Conn., New England Motor Sales Co.
- WAAS, Decatur, Ga., Georgia Radio Co.
- WAAT, Jersey City, N. J., Jersey Bell.
- WAAW, Omaha, Neb., Omaha Grain Exchange.
- WAAY, Youngstown, Ohio, Younging Rayner Music Co.
- WAAZ, Emporia, Kans.; Daylight 10 miles; also 500-1000 miles; each Tuesday and Thursday from 7 to 8 p. m. Acknowledge all communications at 7:15 p. m. The Hollister Miller Motor Co.
- WABA, Lake Forest, Ill.; 266 meters, 100 watts; Lake Forest College.
- WABB, Harrisburg, Pa.; 266 meters, 10 watts; Dr. John B. Lawrence.
- WABC, Anderson, Ind.; 299 meters, 10 watts; Fufwider-Grimes Battery Co.
- WABD, Dayton, Ohio; 286 meters, 10 watts; Parker High School.
- WABE, Washington, D. C.; 283 meters, 50 watts; Y. M. C. A.
- WABF, Mt. Vernon, Ill.; 234 meters, 250 watts; Mt. Vernon Register-News Co.
- WABG, Jacksonville, Fla.; Arnold Edwards Piano Co. 243 meters; 10 watts.
- WABI, Banner, Mo.; Bangor Railway and Elec. Co.; 240 meters; 50 watts.
- WABJ, South Bend, Ind.; The Radio Laboratories; 240 meters; 50 watts.
- WAJT, Marshall, Mo., Kelly-Vawter Jewelry Co.
- WAJU, Yankton, S. D., Yankton College.
- WABV, Sandusky, Ohio; 234 meters, 100 watts; Lake Shore Tire Co.
- WBAW, Lafayette, Ind., Purdue University.
- WBAD, Minneapolis, Minn., Sterling Elec. Co. & Journal Printing Co.
- WBAF, Peoria, Ill., Bradley Polytechnic Inst.
- WBAF, Moorestown, N. J., Fred M. Middleton.
- WBAQ, Bridgeport, Pa., Diamond State Fibre Co.
- WBAM, New Orleans, La., I. B. Renssion.
- WBAN, Englewood, N. J., Wireless Phone Corp.
- WBAO, Decatur, Ill.; 180 miles; occasional; sermons; James Millikin Univ.
- WASP, Fort Worth, Tex.; 4000 miles; Markets and News; Feature concert Monday to Friday inclusive; 9:30 p. m. to 10:45 p. m. Central Time; Quiet nights Saturday and Sunday. The Star-Telegram.
- WBSA, South Bend, Ind., Myron L. Harmon.
- WBAU, Hamilton, Ohio, Republican Publishing Co.
- WBAV, Columbus, Ohio, Ermer & Hopkins Co.
- WBAW, Marietta, Ohio, Marietta College; 245 meters; 100 watts.
- WBAX, Wilkes-Barre, Pa., John H. Stenger, Jr.
- WBSSA, Newark, O.; 240 meter, 20 watts; Newark Radio Lab.
- WBSB, Sterling, Ill.; 229 meter, 50 watts; Sterling Radio Equipment Co.
- WBSD, Reading, Pa.; Barbey Battery Service; 224 meters; 50 watts.
- WBL, Anthony, Kans.; T & H Radio Co.; 261 meters; 100 watts.
- WBS, Newark, N. J.; Radius 500 mi.; Musical and Educational, week days: 10:30 to 11 a. m.; 1:00 to 1:15 p. m.; 2:15 to 2:30 p. m.; 7:30 to 8:30 p. m.; Sundays: 9 to 10:30 a. m.; 1 to 3 p. m.; D. W. May, Inc.
- WBT, Charlotte, N. C.; 1260 miles; 11 a. m. weather report 4:55; 4:30 p. m. mechanical music; 8 p. m. Market Report; 8:30 Tuesday and Friday regular concert; 7:30 p. m. Sunday, Church Southern Radio Corp.
- WBU, Chicago, Ill., City of Chicago.
- WBSZ, Springfield, Mass., Westinghouse Elec. & Mfg. Co.
- WBC, Newburgh, N. Y., Newburgh Daily News; Newburgh News Printing & Pub. Co.
- WCAC, Fort Smith, Ark., John Fink Jewelry Co.
- WCAD, Canton, N. Y., St. Lawrence University.
- WCAE, Pittsburgh, Pa.; 12:30 news and reports; 3:30 weather reports; 4:15 Closing Market reports; 7:30 Late news and lecture; 8:30 musical programs; Kaufmann Beer Co.
- WCAG, New Orleans, La., Daily States Pub. Co.
- WCAH, Columbus, Ohio, Daily program 11:30 to 12:30; Every Tuesday evening at 7, musical program; C. A. Entenried Electric Co.
- WCAI, San Antonio, Texas, Southern Equipment Co.
- WCAJ, Univ. Place, Neb., Nebraska Wesleyan University.
- WCAK, Houston, Texas, Alfred P. Daniel.
- WCAL, Northfield, Minn., St. Olaf College.
- WCAM, Villanova, Pa., Villanova College.
- WCAD, Baltimore, Md., Sanders & Stanton Co.
- WCAR, San Antonio, Texas, Alamo Radio Elec. Co.
- WCAS, Minneapolis, Minn., Wm. H. Dunwoody Industrial Inst.
- WCAT, Rapid City, S. Dak., South Dakota School of Mines.
- WCAU, Philadelphia, Pa.; 1000 miles; Daily 10:30 a. m.; 2:30 p. m.; 8:30 p. m.; regular concert 10 to 12 noon; Tuesdays, Fridays, Saturdays; Durban & Co., Inc.
- WCAV, Little Rock, Ark., J. C. Dice Elec. Co.
- WCAW, Omaha, Neb., Woodmen of the World.
- WCAX, Burlington, Vermont, University of Vermont.
- WCAY, Milwaukee, Wis., Kesselman O'Driscoll Co.
- WCBA, Allentown, Pa.; Chas. W. Hainbach; 280 meters; 5 watts.
- WCBS, Greenville, O.; 240 meters, 100 watts; K. & K. Radio Supply Co.
- WCC, Minneapolis, Minn., Findley Elec. Co.
- WCK, St. Louis, Mo., Stix Beer & Fuller.
- WCM, Austin, Texas, Univ. of Texas.
- WCN, Worcester, Mass., Clark University.
- WCX, Detroit, Mich., Detroit Free Press.
- WDAD, Lindsburg, Kas.; Central Kansas Radio Supply.
- WDAE, Tampa, Fla., Tampa Daily News.
- WDAF, Kansas City, Mo.; Kansas City Star; 411 meters; 500 watts. Regular concerts on Mon, Wed. and Fri. nights from 8 to 9:30. Concerts from 3:30 to 4:30 p. m. each afternoon except Sun. Baseball scores 3:25, 4:00, 4:30, 5:00, and 5:50 p. m. Marketgram and weather forecast 5:55 nightly, except Sun. Educational features and musical program 6 to 7 o'clock each night except Sunday. "Nighthawk" Frolic, Coon Sanders orchestra at the Hotel Muehlebach nightly except Sun. 11:45 p. m. to 1 a. m.
- WDAG, Amarillo, Texas, K. Lawrence Martin.
- WDAG, Brownsville, Pa., Hartman-Riker Elec. & Mach. Co.
- WDAH, El Paso, Tex., Trinity Methodist Church.
- WDAI, Syracuse, N. Y., Hughes Electrical Corp.
- WDAJ, College Park, Ga., Atlanta & West Point R. R. Co.
- WDAK, Hartford, Conn., Hartford Courant.
- WDAL, Jacksonville, Fla., Florida Times Union.
- WDAP, Dallas, Texas, Automobile Elec. Co.
- WDAQ, Chicago, Ill., markets, and concerts 300; Daily on all business days: 9:30 a. m. receipts and shipments; estimated car lots; local weather report; opening futures market in wheat, corn, oats, rye, barley, pork, lard and ribs. 10 a. m. Future quotations, live stock receipts and prices; 10:30 a. m. futures quotations; 11 and 11:30 a. m. same; 12 noon, futures and cash grain prices; 12:30 and 1 p. m. futures quotations; 1:20 p. m. closing futures quotations and high and low for day. Cash grain prices, Gross bids for east grain to arrive, 6 p. m. closing quotations; news items. On Saturdays closing prices at 12:05 p. m. instead of 1:20 p. m. Visible supply changes sent when posted. Regular concert schedule 10 p. m. Tuesdays, Thursdays and Saturdays. Sunday evenings 9 p. m. and 10 p. m. Chicago Board of Trade official station.
- WDAQ, Philadelphia, Pa.; Lit Brothers.
- WDAS, Worcester, Mass., Samuel A. Wallis.
- WDAU, New Bedford, Mass., Slocum & Kilburn.
- WDAX, Centerville, Iowa, First Nat'l Bank.
- WDAY, Fargo, N. D.; 244 meters, 50 watts; Fargo Radio Service Co.
- WDM, Washington, D. C., Church of the Covenant.
- WDT, New York, N. Y., Ship Owners Radio Service.
- WDZ, Tuscola, Ill., James L. Bush.
- WEAA, Flint, Mich., Fairbank & Lathrop.
- WEAS, Fort Dodge, Iowa, Standard Radio Equip. Co.
- WEAD, Atwood, Kans., Northwest Kansas Radio Supply Co.
- WEAE, Blacksburg, Va., Virginia Polytechnic Inst.
- WEAF, New York City, N. Y., Western Electric Co.
- WEAG, Edgewood, R. I., Nichols-Hineline-Bassett Lab.
- WEAH, Wichita, Kans., Wichita Board of Trade and Lander Radio Co.
- WEAI, Ithaca, N. Y., Cornell University.
- WEAT, Vermillion, S. Dak., University of South Dakota.
- WEAK, St. Joseph, Mo., Julius B. Abercrombie.
- WEAM, North Plainfield, N. J., Borough of N. Plainfield.
- WEAN, Providence, R. I., The Shepard Co.
- WEAO, Columbus, Ohio, Ohio State University.
- WEAP, Mobile, Ala., Mobile Radio Co.
- WEAQ, Berlin, N. H., Y. M. C. A.
- WEAR, Baltimore, Md., Balt. American & News Pub. Co.
- WEAS, Washington, D. C., The Hecht Co.
- WEAU, Sioux City, Iowa, Davidson Bros. Co.
- WEAV, Rushville, Nebr., Sheridan Elec. Service Co.
- WEAX, Little Rock, Ark., T. J. M. Daly.
- WEAY, Houston, Texas, Will Horwitz, Jr.
- WEAZ, Waterloo, Iowa, Donald Redmond.
- WES, St. Louis, Mo., The Benwood Co., Inc.
- WEH, Tulsa, Okla., Midland Refining Co.
- WEV, Houston, Texas, Hurlburt-Still Elec. Co.
- WEW, St. Louis, Mo., St. Louis Univ.
- WEW, St. Louis, Mo., Market and weather reports at 9 a. m., 10 a. m., and 2 p. m.; no other regular program; St. Louis University.
- WFAC, Wichita, Kansas, Cosradio Co.
- WFAA, Dallas, Texas, A. H. Belo & Co.
- WFAW, Miami, Fla., 1500 miles; 7:30 to 9 p. m. concerts including Arthur Pryor's Band evenings and W. J. Bryan Sunday School, Sunday a. m.; Miami Daily Metropolitan & Electrical Equipment Co.
- WEAB, Syracuse, N. Y., C. F. Woese.
- WFAF, Poughkeepsie, N. Y., H. C. Sprattley Radio Co.
- WFAE, Watertown, N. Y., Radio Engineering Lab.
- WFAH, Port Arthur, Texas, Elec. Supply Co.
- WFAJ, Asheville, N. C., Hi-Grade Wireless Instrument Co.
- WFAK, Brentwood, Mo., Domestic Electric Co.
- WFAW, St. Cloud, Minn., Granite City Elec. Co. and Times Pub. Co.
- WFAN, Hutchinson, Minn., Hutchinson Electric Service Co.
- WFAQ, Cameron, Mo., Cameron Radio Co. and Mo. Wesleyan College.
- WFAF, Sioux Falls, S. Dak.; also 1000 miles; also 1000 miles; also 1000 miles.
- WFAZ, Lincoln, Nebr., Univ. of Nebr. Dept. of Elec. Engineering.
- WFAV, Charleston, S. Carolina, S. C. Radio Shop.
- WFI, Philadelphia, Penn., also Strawbridge & Clothier.
- WGAC, Brooklyn, N. Y., Orpheum Radio Stores Co.
- WGAD, Ensenada, Porto Rico, Spanish-American School of Radio-teleggraphy.
- WGF, Des Moines, Iowa 300 miles; Musical and entertainment Tuesday and Friday 7:30 p. m.; Church Services Sunday at 8 p. m. or 7:45 p. m. as announced; Special programs as announced. Bertrams and Tribune.
- WGAI, Shenandoah, Iowa, W. H. Gass.
- WGAL, Lancaster, Pa.; Lancaster Elec. Supply Co. 248 meters; 10 watts.
- WGAM, Orangeburg, S. C., Orangeburg Radio Equip. Co.
- WGAN, Pensacola, Fla., Cecil E. Lloyd.
- WGAQ, Shreveport, La., Glenwood Radio Corp.
- WGAH, Fort Smith, Ark., Southwest American.
- WGAU, Wooster, Ohio; 228 meters, 50 watts; Marcus G. Limb.
- WGAV, Savannah, Ga., B-H Radio Co.
- WGAW, Altoona, Pa., Ernest C. Albright.
- WGAZ, Washington Court House, Ohio, Ohio Radio Elec. Co.
- WGAZ, Madison, Wis., North Western Radio Co.
- WGAZ, South Bend, Ind., South Bend Tribune.
- WGI, Medford, Hillside, Mass., Am. Radio & Research Corp.
- WGL, Philadelphia, Pa., Theat. F. Lowieit.
- WGM, Atlanta, Ga., Atlanta Constitution.
- WGR, Buffalo, N. Y., Federal Tel. & Tele. Co.
- WGV, New Orleans, La., Interstate Elec. Co.
- WGY, Schenectady, N. Y., General Elec. Co.
- WHA, Madison, Wis., Univ. of Wis.
- WHA, Iowa City, Ia.; 500 miles; 8:30 p. m. Monday, instruction; Tuesday, concert; Wednesday, popular lecture; Friday, University News; public lectures and concerts irregularly; State University of Iowa.
- WHAS, Galveston, Texas, Clark W. Thompson (Fellman's Dry Goods Co.)
- WHAC, Waterloo, Iowa, Cole Bros. Elec. Co.
- WHAD, Milwaukee, Wis.; Marquette Univ.
- WHAE, Sioux City, Iowa, Automotive Elec. Service Co.
- WHAQ, Cincinnati, Ohio, Univ. of Cincinnati.
- WHAJ, Joplin, Mo.; 1324 miles; Concerts, markets, weather, etc. Tuesday and Thursday evenings 8 to 10; Daily except Sundays: 10 a. m. to 2 p. m.; Saturday night special: 11 to 12:30; Hafer Supply Co.
- WHAJ, Davenport, Iowa, Radio Equip. & Mfg. Co.
- WHAJ, Bluefield, W. Va., Bluefield Daily Telegraph and E. K. Kitts.
- WHAJ, Clarksburg, W. Va., Roberts Hdwe. Co.
- WHAL, Lansing, Mich., Lansing Capitol News.
- WHAJ, New York, N. Y. Daily weather reports 2:40 p. m.; Organ 2:45, 5:00, 8:45; Orchestra 3:00, 7:00; Bed-time stories, Sport results, Business reports and market reports, the latter on 485 meters, 7:15 p. m.; Sunday—Radio Chapel Service, 8:15 p. m.; University of Rochester.
- WHAD, Savannah, Ga., Frederick A. Hill; every evening 8 to 9; Saturday nights, 12:30 to 1:30 a. m.
- WHAP, Decatur, Ill., Deway L. Otis.
- WHAD, Washington, D. C., Seimes Motor Co.
- WHAS, Louisville, Ky., Courier Journal and Louisville Times Co.
- WHAU, Wilmington, Del., Wilmington Elec. Spec. Co.
- WHAU, Tampa, Fla., 100 miles; 12 to 1, 4 to 5 p. m. music; Pierce Electric Co.
- WHX, Des Moines, Iowa; 300 miles; 5:45 p. m. to 6:15 p. m. Daily; 8:00 p. m. to 10 p. m. Wednesday evenings; Central Standard time; Iowa Radio Corp.
- WHAY, Huntington, Ind., Huntington Press.
- WHAY, Syracuse, N. Y., Renaissance Institute.
- WHB, Kansas City, Mo., Sweeney Auto & Tractor School.
- WHB, Morgantown, W. Va., W. Va. University.
- WHK, Cleveland, Ohio, Warren R. Cox.
- WHN, Ridgewood, N. Y., Times Printing & Pub. Co.
- WHU, Toledo, Ohio, Wm. B. Duck Co.
- WHAS, Rockford, Ill., Joslyn Automobile Co.
- WHAC, Galveston, Texas, Galveston Tribune.
- WHAD, Ocean City, N. J., Ocean City Yacht Club.
- WIAE, Vinton, Iowa, Mrs. Robt. E. Zimmerman.
- WIAF, New Orleans, La.; G. A. DeCortina, 10 Marlborough Gate; 234 meters, 10 watts.
- WJAG, Norfolk, Nebr.; 200 miles News and Markets 12:15, 3:30 and 5:30 p. m. The Huse Publishing Co. The Norfolk Daily News.
- WIAH, Newton, Iowa, Continental Radio & Mfg. Co.
- WIAI, Springfield, Mo., Electric Eye Home Elec. Co.
- WIAJ, Neenah, Wis., Fox River Valley Radio Supply Co.
- WIAK, Omaha, Nebr.; 7:45 a. m. Livestock receipts; 9:10 a. m. Livestock receipts and opening on hogs; 10:15 a. m. rainfall and temperature report and weather forecast for Nebraska and Iowa, Livestock market; 12 m. cattle, hog and sheep market; 1:50 p. m. rainfall and temperature report and weather forecast for Nebraska and Iowa; market detail; 3:50 p. m. complete market reports and estimated receipts for next day; Daily Journal-Stockman.
- WIAJ, Milwaukee, Wis., School of Engineering.
- WIAP, Springfield, Mass., Radio Development Corp.
- WIAQ, Marion, Ind., Chronicle Pub. Co.
- WIAR, Paducah, Ky., Musical 3:30 to 4 p. m. and 7 to 8 p. m. except Sundays. Paducah Evening Sun; Albert Bennett, operator.
- WIAS, Burlington, Iowa, Hawk-Eye Home Elec. Co.
- WIAT, Toledo, Mo., Leon T. Now.
- WIAU, Le Mars, Iowa, Am. Trust & Savings Bank.
- WIAV, Birmingham, N. Y., N. Y. Radio Lab.
- WIAW, Saginaw, Mich., Saginaw Radio & Elec. Co.
- WIAV, Neenah, Wis.; 224 meter, 100 watts; Fox River Valley Radio Supply Co.
- WIK, McKeesport, Pa., K. & L. Elec. Shop.
- WIL, Washington, D. C., Continental Elec. Supply Co.
- WIP, Philadelphia, Pa., Cino Radio Mfg. Co.
- WIZ, Cincinnati, Ohio, American Radio Co.
- WIAS, Lincoln, Nebr., American Radio Co.
- WIAD, Waco, Texas, Jackson's Radio Engrs. Lab.
- WIAF, Muncie, Ind.; 1800 miles; 7:30 to 8 Monday, Wednesday, Friday evening, music; 6:30 to 7 p. m. Saturday, music; 8:30 to 4 every afternoon, News; 10:30 to 12 M. Sundays, Church service. Smith Electric-Muncie Press.

(Continued on next page.)

Complete Corrected List of U. S. and Canadian Broadcasting Stations

- WJAJ, Dayton, Ohio 200 miles; Sunday 8:40, 9:15 Religious; Wednesday 9:15, 9:45 Entertainment; Friday 9:15 to 9:45 Entertainment. Y. M. C. A.
- WJAK, Stockdale, Ohio White Radio Lab.
- WJAM, Cedar Rapids, Iowa, Evening Gazette.
- WJAN, Peoria, Ill. 250 miles; Daily except Sunday; 9 a. m. Peoria Livestock; 9:15 a. m. Special Weather Information; 11:30 a. m. weather, opening livestock and market quotations; 1:30 p. m. Closing livestock and markets, official weather information; talk to women by Phyllis Ann; Monday and Thursday, government agramms; 5:30 p. m. baseball reports during season; Tuesday, Thursday and Saturday, special concerts as announced at 9:15 p. m.; One musical number precedes each broadcasting. Peoria Evening Star.
- WJAP, Duluth, Minn. 1500 miles; Sunday 11 a. m. 12:30 p. m. Church Service and organ recital; First Methodist Church, Rev. Chas. N. Pace, Pastor. Monday 8: p. m. to 9 p. m. musical; Thursday 8 p. m. to 9 p. m. musical; Kelley Duluth Co.
- WJAO, Topeka, Kans., Capper Publications.
- WJAR, Providence, R. I., The Outlet Co., J. Samuels & Bros.
- WJAS, Pittsburgh, Pa., Pittsburgh Radio Supply House.
- WJAT, Marshall, Mo., Kelley-Yawter Jewelry Co.
- WJAX, Cleveland, Ohio, Union Trust Co.
- WJAZ, Chicago, Ill., Chicago Radio Lab.
- WJD, Granville, Ohio; 229 meters, 50 watts; Richard Harris Howe.
- WJH, Washington, D. C., White & Boyer Co.
- WJX, New York, N. Y., De Forest Radio Telephone & Teleg. Co.
- WJF, New York, N. Y., Corp. of America; Acelin Hall, 455 meters.
- WKAA, Cedar Rapids, Ia.; Daily; weather reports, crop reports, government reports; Mondays, Thursdays and Saturdays; music; H. P. Paer.
- WKAC, Lincoln, Neb.; Star Publishing Co.; 275 meters; 100 watts.
- WKAF, Wicliita Falls, Texas, W. S. Radio Supply Co.
- WKAM, West Palm Beach, Fla., Planet Radio Co.
- WKAK, Okemah, Okla., Okfuskee County News.
- WKAO, Orange, Texas, Gray & Gray.
- WKAL, Montgomery, Ala., Alabama Radio Mfg. Co.
- WKAP, Cranston, R. I., Dutee W. Flint.
- WKAQ, San Juan, Porto Rico, Radio Corp. of Porto Rico.
- WKAR, East Lansing, Mich., Mich. Agril. College.
- WKAS, Springfield, Mo., L. E. Lines Music Co.
- WKAU, Laconia, N. H., Laconia Radio Club.
- WKAU, Beloit, Wis.; 242 meters, 10 watts; Turner Cycle Co.
- WKAX, Britton, S. D.; W. A. Hane; 231 meters; 15 watts.
- WKAY, Gainesville, Ga., Branau College.
- WKC, Baltimore, Md., Jos. M. Zamoski Co.
- WKN, Memphis, Tenn., Ebleman-Crosby Co.
- WKY, Oklahoma City, Okla., Oklahoma Radio Shop.
- WLZ, Fairfeld, Ohio, U. S. Army.
- WLAC, Raleigh, N. C., N. C. State College.
- WLAB, Minneapolis, Minn., Cutting & Walsh Radio Corp.
- WLAH, Syracuse, N. Y., Samuel Woodworth.
- WLAJ, Waco, Texas, Waco Elec. Supply Co.
- WLAK, Bellows Falls, Vt., Vermont Farm Machine Co.
- WLAL, Tulsa, Okla., Tulsa Radio Co.
- WLAN, Houlton, Me., Putnam Hdve. Co.
- WLAP, Louisville, Ky., W. V. Jordan.
- WLAR, Kalamazoo, Mich., Cutting & Schilling.
- WLAS, Hutchinson, Kans., Hutchinson Grain Radio Co.
- WLAT, Burlington, Iowa, Radio Specialty Co.
- WLAV, Pensacola, Fla.; daily musical program, 8 to 9 p. m.; The Electric Shop.
- WLAW, New York, N. Y., New York Police Dept.
- WLAX, Greencastle, Ind., Greenacres Community Broadcasting Station.
- WLAY, Fairbanks, Alaska, Northern Commercial Co.
- WLBN, Warren, Ohio, Hutton & Jones Elec. Co.
- WLB, Minneapolis, Minn., Univ. of Minn.
- WLK, Indianapolis, Ind., Hamilton Mfg. Co.
- WLW, Cincinnati, Ohio, Crosley Mfg. Co.
- WMA, Anderson, Ind., Arrow Radio Lab.
- WMAE, Oklahoma City, Okla., Radio Supply Co.
- WMAF, Cazenovia, N. Y.; J. Edw. Page; 261 meters; 50 watts.
- WMAH, Rockport, Mo., Atchinson County Mail.
- WMAI, El Paso, Texas, Round Hill Radio Corp.
- WMAJ, Liberal, Kans., Tucker Elec. Co.
- WMAK, Lincoln, Neb., General Supply Co.
- WMAJ, Kansas City, Mo., Drivers Telegram.
- WMAK, Lockport, N. Y., Norton Labs.
- WMAI, Trenton, N. J., 100 miles; 7:30 to 9 p. m. Mondays and Thursdays, musical programs, lectures etc.; Trenton Hardware Co.
- WMAW, Beaumont, Texas, Beaumont Radio Equip. Co.
- WMAN, Columbus, Ohio, First Baptist Church.
- WMAP, Easton, Pa., Utility Battery Service.
- WMAQ, Fair Store Building, Chicago; 4:35 to 5 p. m. daily; 7 to 7:30 p. m. Monday, Wednesday, Friday and Saturday; 7 to 8 p. m. Tuesday and Thursday; 9:15 to 10 p. m. daily; Chicago Daily News and Fair Department Store.
- WMAE, Waterloo, Iowa, Waterloo Elec. Supply Co.
- WMAV, Duluth, Minn., Paramount Radio Corp.
- WMAW, Auburn, Ala., Polytechnic Inst.
- WMAW, Wabpeton, N. D., Wabpeton Elec. Co.
- WMAA, Ann Arbor, Mich., K. & K. Radio Supply Co.
- WMAV, St. Louis, Mo., 600 miles; Religious services Sunday, 11 a. m. and 8 p. m.; Tuesday at 7 p. m.; Kingshighway Presbyterian Church.
- WMAZ, Macon, Ga., Mercer University.
- WMM, Cincinnati, Ohio, Precision Equipment Co.
- WMM, Washington, D. C., Doubleday-Hill Electric Co.
- WMAE, Bowling Green, Ky., Daily News.
- WMAE, Boston, Mass.; Monday 4 to 5 p. m. (silent at night) Tuesday 4 to 5 p. m. and 7 to 8:30 p. m. Wednesday 4 to 5 p. m. 9:30 to 11 p. m. Thursday 4 to 5 and 7 to 8:30 p. m. Friday 4 to 5 and 8 to 9:30 p. m. Saturday 4 to 5 and 9:30 to 11 p. m. The Shepard Stores; J. J. Fanning, announcer; Samuel Curtis, operator.
- WMAE, Norman, Okla., Okla. Radio Engineering Co.
- WMAE, Omaha, Neb., R. J. Rockwell.
- WMAE, Syracuse, N. Y., Syracuse Radio Telephone Co.
- WMAE, Springfield, Ohio, Wittenberg College.
- WMAE, Charleston, S. C., Charleston Radio Elec. Co.
- WMAE, Austin, Texas, Radio Corp.
- WMAE, Philadelphia, Pa., 1000 miles; Talks, Radio information, music, Chapel Service. Wednesday 7:30 p. m.; Saturday 7:30 p. m.; Sunday 2:30 and 4:30; Every day 12:15, 1 p. m. Lonnie Bros. Co.
- WMAE, Knoxville, Tenn., People's Tel. and Tel. Co.
- WMAE, Baltimore, Md., Shipowners' Radio Service.
- WMAE, Fortress Monroe, Va., Henry Kuntzman.
- WMAE, Yankton, S. Dakota; 244 meters, 100 watts; Dakota Radio Apparatus Company.
- WNI, Albany, N. Y., Shotton Radio Mfg. Co., Inc.
- WNO, Jersey City, N. J., Wireless Telephone Co. of Hudson Co., N. J.
- WOOA, Ardmore, Okla.; radius 1,500 miles; Tuesdays and Fridays: musical and educational programs; Dr. Walter Hardy; station operated by G. H. Reitz.
- WOC, Lima, Ohio, Mansu Radio Co.
- WOAE, Fremont, Neb., Medland College.
- WOAF, Tyler, Texas, Tyler Commercial College.
- WOAH, Charleston, S. C., Palmetto Radio Corp.
- WOAI, San Antonio, Tex.; 385 meters; Southern Equipment Company; Programs Daily: 10:30 a. m. Opening markets, U. S. weather forecast, crop reports, road reports, cotton reports, money market, livestock quotations and news bulletins, daily except Sun. 12:15 p. m. Livestock quotations, produce markets, and news bulletins. 3 p. m. Closing markets, cotton reports, grain and market futures and news bulletins. 5 p. m. Complete baseball scores from American National and Texas leagues, final reports on markets, and news bulletins. Daily except Sun. 9:30 to 10:30 p. m. Concerts. Thurs. 7:30 to 8:30 p. m. Musical and Community Programs. Sunday 11:00 a. m. Church Services, 5:00 to 6:00 p. m. Concerts.
- WOAJ, Parsons, Kans., Erving's Electrical Co.
- WOAK, Frankfort, Ky., Collins Hardware Co.
- WOAL, Webster Groves, Mo., Wm. E. Woodard.
- WOAN, Lawrenceburg, Tenn., James D. Vaughan.
- WOAO, Omaha, Neb., 100 miles; Woodmen of the World.
- WOAQ, Portsmouth, Virginia; Portsmouth Kiwanis Club.
- WOAR, Kenoisha, Wis., Henry P. Lundskow.
- WOAS, Middletown, Conn., Bailey's Radio Shop.
- WOAT, Wilmington, Del., Boyd Martell Hamp.
- WOAU, Evansville, Ind., Bowder Bolling Piano Co.
- WOAV, Erie, Pa., Pa. Nat'l Guard.
- WOAX, Trenton, N. J., Franklin J. Wolf.
- WOAW, Omaha, Neb., 100 miles, Woodmen of the World.
- WOAZ, Stanford, Texas, Penick Hughes Co.
- WOCB, Greenville, O.; 240 meters, 100 watts; K. & K. Radio Supply Co.
- WOC, Davenport, Ia. time signals, 10:55 a. m.; weather 11 a. m.; 360 meters, 11:05 opening market quotations, agramms; 12:00 noon, chimes concert; 2:00 p. m. closing stocks and markets; 3:30 p. m. educational talk; 5:45 p. m. chimes concert; 8:35, sandman's visit; 7:00 musical program; 8 p. m. lecture; Sundays, religious and musical and religious features, 9 a. m. to 10 p. m.; Palmer's School of Chiropactic.
- WOI, Ames, Ia., Iowa State College.
- WOK, Pine Bluff, Ark., concerts Tuesday and Friday evenings beginning at 9; Sundays, song service and sermons from churches at 11 a. m. and 7:30 p. m., Arkansas Light & Power Co.
- WOO, Philadelphia, Pa., John Wanamaker.
- WOQ, Kansas City, Mo., Western Radio Co.
- WOR, Newark, N. J., L. Bamberger & Co.
- WOS, Jefferson City, Mo.; first fifteen minutes of every hour from 8 a. m. to 9 p. m., news, markets and music, 360 meters; Monday, Wednesday, Friday nights, 8 to 9:30 concerts; no Sunday program; Missouri State Marketing Bureau.
- WOV, Omaha, Neb., R. B. Howell.
- WOU, Omaha, Neb., Metropolitan Utilities.
- WPA, Fort Worth, Texas, Fort Worth Record.
- WPAA, Waboo, Neb., Anderson & Webster Elec. Co.
- WPAB, State College, Pa.
- WPAC, Okmulgee, Okla., Donaldson Radio Co.
- WPAD, Chicago, Ill., Wieboldt & Co.
- WPAF, Council Bluffs, Iowa, Peterson's Radio Co.
- WPAG, Independence, Mo., Central Radio Co.
- WPAH, Waupaca, Wis., Wisconsin Dept. of Markets.
- WPAJ, New Haven, Conn., Doolittle Radio Corp.
- WPAK, Fargo, N. D., North Dakota Agricultural College.
- WPAK, Columbus, Ohio, Superior Radio & Tel. Equip. Co.
- WPAM, Topeka, Kans., Avesch & Guellet.
- WPAP, Winchester, Ky., Theo. D. Phillips.
- WPAQ, Frostburg, Md., General Sales & Eng. Co.
- WPAQ, Wilmington, Del., Radio Installation Co., Inc.
- WPAP, Beloit, Kans., R. A. Ward.
- WPAS, Amsterdam, N. Y., J. & M. Electric Co.
- WPAT, El Paso, Texas, St. Patrick's Cathedral.
- WPAU, Moorhead, Minn., Concordia College.
- WPAY, Bangor, Me., Bangor Radio Laboratory.
- WPAZ, Charleston, W. Va., Dr. John E. Koeh.
- WPE, Independence, Mo.
- WPG, New Lebanon, Ohio 1500 miles; Program exclusive for the farmer; 12 to 12:15 p. m. News Flashes; 6 to 6:30 p. m. News, Markets; 8 to 9:45 Monday and Wednesday; music and farm program. Nushawg Poultry Farm.
- WPI, Clearfield, Pa., Electric Supply Co.
- WPO, Memphis, Tenn., United Equip. Co.
- WQAW, Washington, D. C.; Catholic University of Am.; 236 meters; 50 watts.
- WQAC, Clemson College, S. C.; Clemson Agriculture College.
- WQAA, Parkersburg, Pa., 1500 miles; 10:30 p. m. every evening. Horace A. Beale, Jr.
- WQAB, Springfield, Mo., Southwest Missouri State Teachers' College.
- WQAC, Amarillo, Texas, E. B. Glah.
- WQAD, Waterbury, Conn., The Electric Co.
- WQAE, Springfield, Vt., Moore Radio News Station.
- WQAF, Sandusky, Ohio, Sandusky Register.
- WQAH, Lexington, Ky., Brock-Anderson Elect. Eng. Co.
- WQAJ, Ann Arbor, Mich., Ann Arbor Times-News.
- WQAK, Dubuque, Iowa, Appel-Higley Elec. Co.
- WQAL, Mattoon, Ill., Cole County Tel. and Tel. Co.
- WQAM, Miami, Fla., Electrical Equipment Co.
- WQAN, New York, N. Y., Calvary Baptist Church.
- WQAP, Lincoln, Neb., Am. Radio Co.
- WQAQ, Abilene, Texas, West Texas Radio Co.
- WQAR, Muncie, Ind., Press Publishing Co.
- WQAS, Lowell, Mass.; Prince-Walter Company.
- WQAT, Westhampton, Va.; Radio Equipment Corp.
- WQAV, Greenville, S. C.; Huntington & Guerry, Inc.
- WQAW, Scranton, Pa., Scranton Times.
- WQAW, Washington, D. C.; Catholic University of America; 236 meters; 50 watts.
- WQAX, Peoria, Ill.; Radio Equipment Co.
- WQAY, Hastings, Neb., Gaston Music & Furniture Co.
- WQAZ, Greensboro, North Carolina; Greensboro Daily Ncw.
- WRAA, Houston, Texas, Rice Institute.
- WRAB, Savannah, Ga.; Savannah Board of Public Education.
- WRAC, Salisbury, N. D., State Normal School.
- WRAD, Marlon, Kansas, Taylor Radio Shop.
- WRAP, Laporte, Ind.; 224 meters, 10 watts; Radio Club, Inc.
- WRAS, Providence, R. I.; Stanley N. Read.
- WRAT, Escanaba, Mich.; Economy Light Co.
- WRAL, St. Croix Falls, Wis.; Northern States-Power Co.
- WRAM, Carthage, Ill., Robert E. Compton & Carthage College.
- WRAN, Galveston, Ill., Leonard Co.
- WRAN, Waterloo, Iowa, 229 meters, 20 watts; Black Hawk Electrical Co.
- WRAD, St. Louis, Mo., Radio Service Co.
- WRAP, Winter Park, Fla.; Winter Park Electric Construction Co.
- WRAR, David City, Neb.; J. C. Thomas; 226 meters; 20 watts.
- WRAS, McLeansboro, Ill.; Radio Supply Co.
- WRAU, Amarillo, Texas, Daily News.
- WRAW, Yellow Springs, O., Antioch College.
- WRAV, Scranton, Pa.; radius 400 ml.; Sunday Chapel service; Wednesday: Selective Musical program, 8:15 to 10; Saturday: 8:15 to 11; Radio Sales Corp.
- WRK, Hamilton, Ohio, Doron Bros. Elec. Co.
- WRL, Schenectady, N. Y., Union College.
- WRM, Urbana, Ill., Univ. of Ill.
- WRP, Camden, N. J., Federal Inst. of Radio Telg.
- WRR, Dallas, Texas, City of Dallas, Police and Fire Signal Dept.
- WRS, Tarrytown, N. Y., Tarrytown Radio Research Lab.; 275 Meters; 50 watts.
- WSAA, Marietta, O., B. S. Sprague Electric Co.
- WSAB, Cape Girardeau, Mo., Southeast Mo. State College.
- WSAC, Clemson College, S. C.; Clemson Agricultural College.
- WSAH, Chicago, Ill.; A. G. Leonard, Jr.; 248 meters, 500 watts.
- WSAJ, Grove City, Pa., Grove City College.
- WSAL, Brookville, Ind.; Franklin Electric Co.
- WSAM, Yellow City, Mo., Yvonne Baptist Church.
- WSAT, Plainview, Texas, The Plainview Electric Co.
- WSAV, Houston, Texas, C. W. Vick Radio Const'n Co.
- WSB, Atlanta, Ga., Atlanta Journal.
- WSL, Utca, N. Y., J. & M. Elec. Co.
- WSY, Birmingham, Ala., Alabama Power Co.
- WTAC, Johnston, Pa., Penn. Traffic Co.
- WTAD, Yellow Springs, O., radius 200 miles; Chas. E. Erbstein.
- WTAU, Tecumseh, Neb., Bugy Battery & Elec. Co.
- WTAW, College Station, Texas; Agric. & Mech. College; 254 meters; 50 watts.
- WTG, Manhattan, Texas, Kans. State Agril. College.
- WTP, Bay City, Mich., Ra-Do Corp.
- WVP, New York, N. Y., Signal Corps, U. S. Army.
- WVAC, Waco, Tex.; 8000 miles; Weather forecasts 11 a. m. daily; musical concerts, 1 p. m. daily; talks on Wednesday and Saturday evenings at 8; Sanger Bros.
- WVAD, Philadelphia, Pa., Wright & Wright, Inc.
- WVAX, Laredo, Texas, Warman Bros.
- WVAY, Chicago, Ill.; Martgold Gardens.
- WVWB, Canton, Ohio, Daily News Printing Co.
- WVWI, Dearborn, Mich., Ford Motor Co.
- WVWJ, Detroit, Mich., Evening News.

(Continued on next page.)

Complete Corrected List of U. S. and Canadian Broadcasting Stations

WVL, New Orleans, La.; Musical and Educational; Loyola University; operated by Dept. of Physics.
 WWX, Washington, D. C., Post Office Dept.
 2XAI, Newark, N. J., Westinghouse Elec. & Mfg. Co.
 2XI, New York City, A. T. & T. Co.

2XJ, Deal Beach, N. J., Amer. Tel. & Telg. Co.
 3XW, Parkersburg, Pa., Horace A. Zeale, Jr.
 3YN, Washington, D. C., Nat'l Radio Inst.
 9ARU, Louisville, Ky., Darrell A. Downard.

Canadian Stations

CFAC, Calgary, Alta., Can. Western Radio Co., Ltd.
 CFCA, Toronto, Ont., Can. Toronto Star.
 CFGB, Vancouver, B. C., Can. Marconi Co.
 CFCE, Halifax, N. S., Can. Marconi Co.
 CFCE, Montreal, P. Q., Can. Marconi Co.
 CFCH, Iroquois Falls, Ont., Can. Abitibi Power & Paper Co., Ltd.
 CFCL, Walkerville, Ont., Can. Motor Products Corp.
 CFCL, Calgary, Alta., Can. W. W. Grant Radio, Ltd.
 CFCL, London, Ont., Can. The London Advertiser.
 CFPC, Fort Frances, Ont., Can. International Radio Develop. Co.
 CFPC, Toronto, Ont., Can. The Bell Telephone Co.
 CFYC, Vancouver, B. C., Can. Victor Westworth Odium.
 CFZC, Montreal, Que., Can. Can. Westinghouse Co., Ltd.
 CHBC, Calgary, Canada, W. W. Grant Radio, Ltd. (Morning Albertan.)
 CHCA, Vancouver, B. C., Can. Radio Corp. of Vancouver, Ltd.
 CHCB, Toronto, Can. Marconi Co.
 CHCC, Edmonton, Alta., Can. Can. Westinghouse Co., Ltd.
 CHCF, Winnipeg, Man., Can. Radio Corp. of Winnipeg, Ltd.
 CHCQ, Calgary, Alta., Can. Western Radio Co., Ltd.
 CHCS, London, Ont., Can. London Radio Shoppe.
 CHCX, Montreal, Que., Can. B. L. Silver.
 CHCZ, Toronto, Ont., Can. Globe Printing Co.
 CHCC, Vancouver, B. C., Can. Can. Westinghouse Co., Ltd.
 CHVC, Toronto, Canada, Metropolitan Motors Co.
 CHXC, Ottawa, Ont., Can. J. R. Booth, Jr.
 CHYC, Montreal, Que., Can. Northern Elec. Co.

CJBC, Montreal, Que., Can. Dupuis-Freres.
 CICA, Edmonton, Alta., Can. Edmonton Journal, Ltd.
 CJCBA, Nelson, B. C., Can. James Gordon Bennett.
 CJCDB, Toronto, Can., T. Eaton, Co.
 CJCE, Vancouver, B. C., Can. Vancouver Sun.
 CJCF, Kitchener, Ont., Can. News Record, Limited.
 CJCG, Winnipeg, Canada, Manitoba Free Press.
 CJCH, Toronto, Ont., Can. United Farmers of Ontario.
 CJCI, St. John, N. B., Can. McLean, Holt & Co., Ltd.
 CJCN, Toronto, Ont., Can. Simons, Arnew & Co.
 CJCS, Halifax, N. S., Can. Eastern Telephone & Telegraph Co.
 CJCY, Calgary, Alta., Can. Edmund Taylor.
 CJG, London, Ont., Can. London Free Press.
 CJNG, Winnipeg, Man., Can. Tribune Newspaper Co.
 CJSC, Toronto, Ont., Can. Evening Telegram.
 CKAC, Montreal, Can. La Presse.
 CKCB, Winnipeg, Man., Can. T. Eaton Co., Ltd.
 CKCD, Vancouver, B. C., Can. Vancouver Daily Province.
 CKCE, Toronto, Ont., Can. Can. Ind. Telephone Co.
 CKCK, Regina, Sask., Can. Leader Pub. Co.
 CKCR, St. John, N. B., Can. Jones Elec. Radio Co., Ltd.
 CKCS, Montreal, Que., Can. The Bell Telephone Co.
 CKCZ, Toronto, Ont., Can. Westinghouse Co., Ltd.
 CKKC, Toronto, Ont., Can. Radio Equipment & Supply Co., Ltd.
 CKOC, Hamilton, Ont., Can. Wentworth Radio Supply Co., Ltd.
 CKQC, London, Ont., Can. Radio Supply Co.
 CKZC, Winnipeg, Man., Can. Salton Radio Eng. Co.

WWV Transmits More Standard Waves

In an effort to permit radio operators and fans to check their wave meters and instruments on standard waves, the Bureau of Standards will transmit standard wave lengths commencing at 10:55 p. m., each night, on July 17, August 15, September 13 and 28 and on October 7.

On the last date, WWV will enable amateurs to calibrate their receiving and transmitting sets, since the band covered will be from 222 to 150 meters, the signals being sent between 1:50 a. m. and 3:41 a. m.

The schedule follows (Keep it for future reference):

Date	Frequency	K-c	Wave length, met.
June 11	400	1000	750 to 300
July 17	425	1500	705 to 200
Aug. 15	425	1500	705 to 200
Sept. 13	425	1500	705 to 200
Sept. 28	500	1700	600 to 176
Oct. 7	1350	2000	222 to 150

(Amateurs)

In continuation of the established practice, the Bureau will transmit the call signals "WWV" both in radio telegraph and telephone, each wave length occupying about nine minutes of time.

Now It Is Zion

WCBD, broadcasting station of Zion City, Ill., is in operation with a wave length of 245 meters. The station cost \$30,000. Wilbur Glenn Voliva, successor of the well-remembered and peppery John Alexander Dowie, will use the station to broadcast his sermons. There also will be songs by the angel choir of five hundred voices and music by the Zion band and the orchestra. Mr. Voliva believes the earth is flat but he, at least, is a few steps ahead of Chris Columbus, so far as radio is concerned. Columbus knew something about navigation, but nary a thing about a loose coupler.

Untaxed Music

KYW has made considerable of a hit with the new jazz melody, "St. Louis Tickle." This number has also been broadcast from several of the member stations of the National Broadcasters' League, 500 North Dearborn street, Chicago. The National Broadcasters' League has received many appreciative letters from members in acknowledgment of the receipt of musical numbers which have been furnished by the league through Harold Rossiter, independent music publisher and Chairman of the Program Committee of the League. The League has been doing effective work in making it unnecessary for broadcasters to depend upon music controlled by the American Society of Authors Composers and Publishers. The American Society insists on a tax for the use of copyrighted music by broadcasters and the broadcasters simply refused to assume the additional expense.

Radio Helps Sermons

Radio broadcasting of the sermons and songs of the Sunday evening club programs, broadcast by KYW from the Orchestra hall, Chicago, has resulted in an increased attendance at these religious services, according to John W. O'Leary, Secretary of the club. Furthermore, contributions of money from distant radio listeners, who have heard the services, have assisted in defraying expenses of the Sunday evening programs.

Long Distance

A wireless message from the Naval station at Cavite, P. I., addressed to San Francisco, for relay to Washington, was picked up in the Washington Radio Central recently and copied before the San Francisco operator indicated its receipt. Needless to say, it was not relayed to Washington. This message was copied without error over 11,500 miles of sea and land.

Audience of 5,000,000

A new record in radio has been added with the report of the complete success of having 5,000,000 persons—the largest number ever addressed—listening recently to the program at Carnegie Hall arranged by the National Electric Light Association.

Stations KYW, Chicago; WEA, New York; KDKA, Pittsburgh, and WGY, Schenectady, were connected out of the hall by telephone wires, duplicate wires being run from the hall to each of the outlying stations.

Martin J. Insull, of Chicago, presided at the meeting, at which Julius H. Barnes, President of the Chamber of Commerce of the United States, spoke.

Boost for League

On with the dance! So say radio fans who cut in on the program sent out by KYW, Westinghouse broadcasting station.

The station is now sending out dance music played by Cope Harvey's orchestra and it is the first time the big station has linked up with an orchestra leader since the American Society of Composers, Authors and Publishers placed a ban on their copyrighted numbers being sent over the radio.

The dance selections are from the independent publishers and have been obtained through the National Broadcasters' League. Fifteen selections were released this week to broadcasters in twenty states and ten more will be released next week.—[Chicago Herald and Examiner.

Exports Increase

During the first three months of 1923 the value of exports of American made radio and wireless apparatus exceeded \$500,000. An increase of over \$30,000 a month, since the first of the year, is shown by figures just issued by the department of commerce.

RADIO AGE INSTITUTE

To insure 100% value to readers of advertisements, as well as 100% value to the advertisers themselves, radio equipment is now being tested and endorsed by the

RADIO AGE INSTITUTE
500 NORTH DEARBORN STREET
CHICAGO, ILLINOIS

No charge is made for testing and approval, and all merchandise will be returned as soon as possible, transportation expenses to be paid by the manufacturer. Lists of makers of approved radio goods will be published from time to time.

SERVICE DEPARTMENT FOR READERS

Please remember that Radio Age has one of the best radio instructors in the United States, who is ready to answer any technical question. This costs subscribers nothing.

FOUND!



A Gold Mine!

Over three hundred pages of fully illustrated instructions on how to build and operate sets! Truly a treasure trove for the home radio experimenter!

Written by experts, diagrammed by experts, tested and proved by experts. And all so simple and clear that the beginner can understand.

Reinartz circuits, with instructions on how to make them and amplify them.

Long Distance crystal sets. How to hook 'em up. How to make the aerials do their darndest.

Kopprasch circuits, Armstrong circuits, readers' circuits on which they have made distance records.

How to make battery chargers. How to make transformers, coils, condensers, variocouplers, loading coils, dry-cell circuits, audio-frequency amplifiers, one-tube loop aerial sets, two-circuit crystal detectors.

Ten issues of RADIO AGE "The Magazine of the Hour," the experimenters' guide.

In One Volume---Cloth Bound---Gold Lettered with one year's subscription to Radio Age!

All for \$4.00 Postpaid

Send money order or check now.

RADIO AGE, Inc.

500 North Dearborn Street
CHICAGO

Scanned from the collections of The Library of Congress



Packard Campus
for Audio Visual Conservation
www.loc.gov/avconservation

Motion Picture and Television Reading Room
www.loc.gov/rr/mopic

Recorded Sound Reference Center
www.loc.gov/rr/record

This file including all text and images are from scans of a private personal collection and have been scanned for archival and research purposes. This file may be freely distributed, but not sold on ebay or on any commercial sites, catalogs, booths or kiosks, either as reprints or by electronic methods. This file may be downloaded without charge from the Radio Researchers Group website at <http://www.otrr.org/>

Please help in the preservation of old time radio by supporting legitimate organizations who strive to preserve and restore the programs and related information.