

REINARTZ CIRCUITS—SEE BACK COVER ANNOUNCEMENT

# RADIO AGE

March, 1923

The Magazine of the Hour

Price  
25 cents

## IN THIS NUMBER

How to Use W-D-11 Tubes with Your  
Crystal Set Coil

How to Make Your Reinartz Panel

The Long Distance Crystal Set

Complete List of Broadcasting  
Stations

Radio Over Electric Wires

*See the Hook-Ups!*



-R.L. Frior, 1923  
13

## RADIO AGE INSTITUTE

To insure 100% value to readers of advertisements, as well as 100% value to the advertisers themselves, radio equipment is now being tested and indorsed by the

RADIO AGE INSTITUTE  
64 WEST RANDOLPH STREET  
CHICAGO, ILLINOIS

No charge is made for testing and approval, and all merchandise will be returned as soon as possible, transportation expenses to be paid by the manufacturer. Lists of makers of approved radio goods will be published from time to time.

## SERVICE DEPARTMENT FOR READERS

Please remember that Radio Age has one of the best radio instructors in the United States, who is ready to answer any technical question. This costs you nothing.

# RADIO AGE

The Magazine of the Hour

Volume 2

MARCH, 1923

Number 2

## CONTENTS

	Page
Grand Opera a Boon to Radio.....	2
Layout and Drilling for Reinartz Tuner with Amplification.....	3
Another Good W-D-11 Vacuum Tube Circuit.....	4
Adapting the Old Tuning Coil to the New W-D-11 Dry Cell Tubes.....	5
How to Make the Crystal Set Do Long Distance Work	6
Wired Wireless for the Millions.....	7
How I Made an Audio-Frequency Amplifier for Simple Set.....	11
Pick-up Records by Our Readers.....	15
Thought Waves from the Editorial Tower.....	17
Radio Bill Held up by Senate.....	18
Service Bulletin of National Broadcasters' League.....	19
Complete List of Broadcasting Stations.....	21
With the Radio Trade.....	28

RADIO AGE is published monthly by  
RADIO AGE, INC.

Publication office, Mount Morris, Ill.  
Editorial and Advertising Offices, Garrick Building, 64 W.  
Randolph St., Chicago.

FREDERICK SMITH, *Editor*  
FRANK D. PEARNE, *Technical Editor*  
M. B. SMITH, *Business Manager*

*Eastern Representative:*  
GEO. W. STEARNS  
Flatiron Building, New York City, N. Y.

Advertising Forms Close on 5th of the Month  
Preceding Date of Issue.

Issued monthly. Vol. 2, No. 2      Subscription price \$2.50 a year.  
Entered as second-class matter September 15, 1922, at the post office at Mount  
Morris, Illinois, under the Act of March 3, 1879.

Copyright, 1923, by RADIO AGE, Inc.

# 6

## Six Reasons

**T**HIS magazine has taken a place as one of the most popular of radio publications for six very good reasons:

1—It publishes each month a complete, corrected list of broadcasting stations, with program schedules. These stations are listed alphabetically by call numbers for ready reference by radio owners.

2—This magazine is the official news medium for the National Broadcasters' League, a nation-wide organization which added sixteen big broadcasting stations to its membership in the last month. Radio owners are interested in broadcasters and broadcasting and they are quick to recognize our leadership in this department.

3—Frank D. Pearne, chief instructor in electricity at Lane Technical High School, Chicago, is technical editor of Radio Age. He made the Reinartz tuner famous with his illustrated Reinartz articles in Radio Age. He writes radio with a peculiarly clear understanding of his subject and a peerless conception of what the radio public wants to know. He makes the masses understand.

4—Elementary radio is fully illustrated by the most accurate of diagrams and drawings. Simplicity in the treatment of the most difficult phases of radio has won the favorable attention of radiowners everywhere.

5—We are publishing the magazine for our readers. We call attention to the columns of letters in this issue written to us by fans in all parts of the country giving their reception records, describing their hook-ups and giving details as to aerial arrangement, amplification, etc. This is reader interest, demonstrated conclusively.

6—This magazine devotes much time and space to all phases of radio, its growth, its needs, its protection, its importance. It aims at constructive treatment of radio in all its departments. It tells the truth about radio and like Andy Gump it "wears no man's collar."

# 6

# Grand Opera a Boon to Radio

**T**HE Chicago Civic Opera Association in January finished one of the most successful seasons ever experienced in Chicago—a season devoted to popular prices which were responsible for packed houses every night during the entire run of ten weeks.

At the same time, KYW, one of the four large radio stations, operated by the Westinghouse Electric & Manufacturing Co., and the only station in the world to broadcast grand opera, also concluded the most important, instructive, and entertaining feature of its daily twelve-hour schedule. During the entire season KYW put in the air productions of the best known operas two nights each week, by courtesy of the Chicago Civic Opera Association, whose hearty cooperation made this feature possible.

During this ten weeks' run of the opera in Chicago thousands of letters were received at the Westinghouse office, carrying words of commendation and thanks from every state in the Union, the majority of the letters having been received from people residing in the more isolated districts of the United States. Station KYW, by broadcasting the more famous works of the great masters, has done much to develop a greater appreciation of classical music among the residents of the United States.

The broadcasting of grand opera was made possible by the installation of special sealed telephone wires in the Auditorium Theatre, connecting the huge theatre directly with the station. Three microphones then picked up the music of the productions as they were produced on the stage. The music then passed over the special wires to the transmitting equipment in the station where it received the proper modulation for broadcasting and was sent out into the ether waves to be tuned in by millions of enthusiastic owners of receiving sets.

KYW now has the reputation of being the only station in the world to broadcast grand opera. This year radio has given the people of the United States, who are fortunate enough to own receiving sets, an opportunity to hear the brilliant interpretation and singing of Virgilio Lazzari in "Aida," Ina Bourskaya, as Amneris in "Aida,"



Giacomo Rimini, in "The Barber of Seville," and Claudia Muzio in the role of Aida, in the opera of that name.

Picture sitting comfortably at home in your favorite arm chair, listening to the beautiful voices of such internationally famous singers as those just named, and you are visualizing the principal cause for the popularity of opera as broadcast by KYW.

The announcer at KYW, the other evening, addressed his great audience on the subject of difficulties overcome by the expert staff which operates a big transmitting station. He pointed out

that opera was one of the most difficult things to broadcast for the reason that the singers are at various distances, and that special arrangement has to be made to "pick them up" wherever they may be upon the stage.

It was necessary, therefore, for the man in charge to have ten microphones stationed on the stage and near the orchestra pit. Different microphones were used for solos and for orchestra numbers. The operator must know the operas thoroughly so that he may be able to make quick shifts, being always aware of what is coming next.

# RADIO AGE

"The Magazine of the Hour"

M. B. SMITH  
PUBLISHER

PUBLISHED MONTHLY GARRICK BLD'G CHGO.

FREDERICK SMITH  
EDITOR

## Layout and Drilling for Reinartz Tuner with Amplification

By F. D. PEARNE

SO MANY of our readers have requested information regarding the layout of panels for the Reinartz tuner that we are giving full instructions for same in this issue. Many different arrangements have been shown in various magazines and papers, some of which work out and some do not. This layout is the standard arrangement, designed by the writer and used on more than one hundred sets that have been built under his supervision, so that there is no question about how it will work out.

The panel should be made of bakelite, or hard rubber, 18 inches long, 8 inches wide, and 3-16 of an inch thick. While this arrangement provides for the tuner and one stage of radio and one stage of audio frequency, or the tuner and two stages of audio frequency, as desired, it can also be used for the

tuner only, leaving the other two stages blank, until the builder wishes to add to the set.

The primary idea is to furnish space for the entire combination in a condensed form, which may be added to later on. The holes on the extreme ends of the panel are to be used for the binding posts. The two at the top of the left hand end are for the aerial and ground, while the two at the bottom of the left hand end are used for the positive and negative of the "A" battery. The three binding posts at the right end of the panel, at the top, are used for the terminals of the "B" battery, the top one being connected to the negative, the center one to the 22 1-2 volt positive, and the lower one to the 45 volt positive.

The two lower posts on the right hand end are used for a loud speaker connection, or for an extra set of

head phones. In drilling the holes for the switch contacts, the radius is given as 1 1-8 inches. This of course provides for switch levers of this length which is standard, but as there are several other standard sizes, it would be well to purchase the switches first, as it may be possible that the dealer may not have this size in stock and it might be necessary to use a different radius to fit the particular switch lever obtained.

It will also be noticed that two of the holes in each switch layout are marked "S." These particular holes are to be used for the stops for the switch lever and should be set in towards the center slightly, otherwise the switch lever will pass them and they will be of no use. For this reason it will be noted that the radius for these stops is given as

(Continued on next page.)

PANEL FOR REINARTZ TUNER WITH 2 STAGES OF AMPLIFICATION,

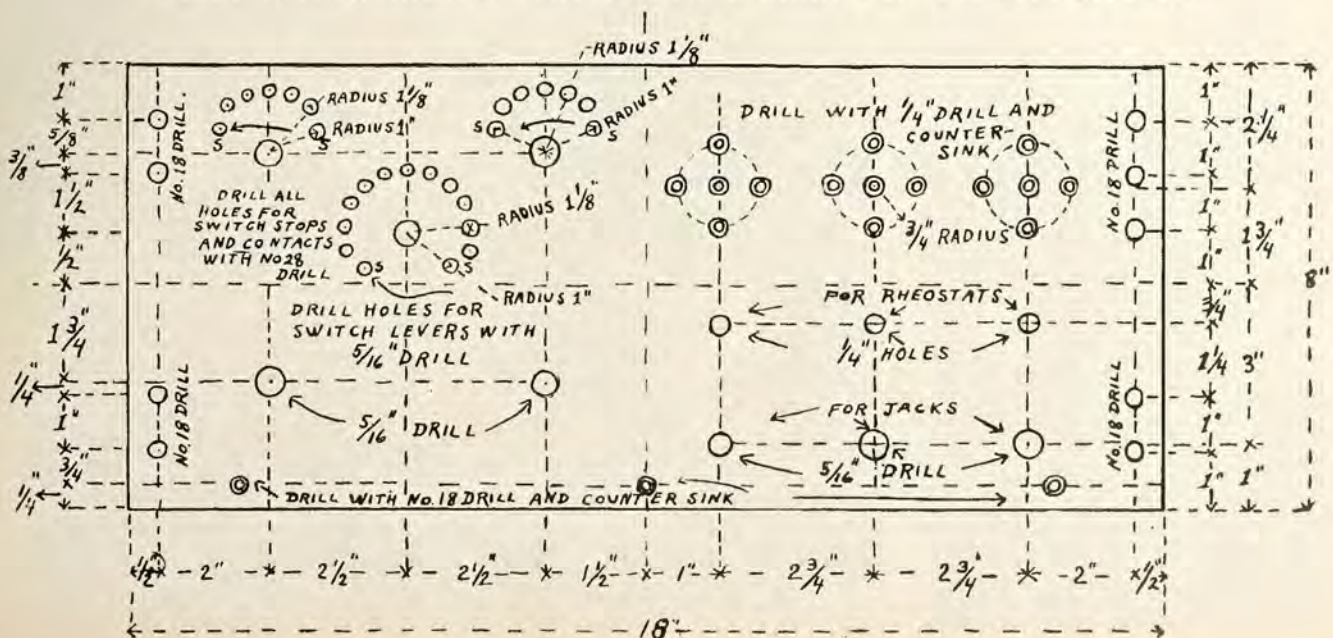

# Another Good W-D-11 Vacuum Tube Circuit

By F. D. PEARNE

**T**HE simple W-D-11 vacuum tube circuit shown herewith is well adapted to fit the modest means of the amateur who desires to build an inexpensive set and still get good results. This outfit when used on an aerial of from 100 to 150 feet in length will bring in long distance stations very nicely.

## Variometer Inductance.

The inductance used in this case is obtained from an ordinary variometer which makes possible a very fine tuning from zero to the maximum capacity of the coils. The circuit is somewhat different from the other standard circuits, in that the variometer is connected between the plate and the grid. A 43 plate variable condenser is placed between the grid circuit and the ground. This combination arranged as shown in the drawing makes it possible to get very close tuning and is especially valuable in clearing up interference. The plate battery is the ordinary standard 22 1-2 volt battery which is usually found to be a little high for the proper working of the W-D-11 tube, so when purchasing this battery, be sure to get one which is tapped at different points, so that any voltage from 16 to 22 1-2 may be obtained as these tube characteristics vary considerably, and the pressure which is right for one tube is wrong for another.

It is very important that the plate voltage be just exactly right for the particular tube used. The grid leak and condenser shown in the drawing are the standard units used on most sets and can be found in any radio supply store, but if one wants to be a little more accurate, he can use a variable grid leak and variable condenser for this purpose. The variable condenser, however, is not so important as the variable grid leak.

The circuit shows a spring jack inserted between the "B" battery and the plate, so that a plug may be used for connecting and disconnecting the headphones. Many users of this circuit have used a filament control jack instead of the plain two way jack shown in the drawing. This is a very good thing to do as it is an assurance that the battery will not be left connected to the filament when the set is not in use.

## Amplification.

The ordinary one or two step amplifier may be used in conjunction with this set, or by changing the sockets to fit W-D-11 tubes the amplifier, as well as the tuner, may be operated on 1 1-2 volts, thereby doing away with the storage battery, used on the ordinary amplifier. If W-D-11 tubes are used on the amplifier, one dry cell should be used for each tube inserted in the circuit. These cells should be connected in parallel, however, and not in series. This

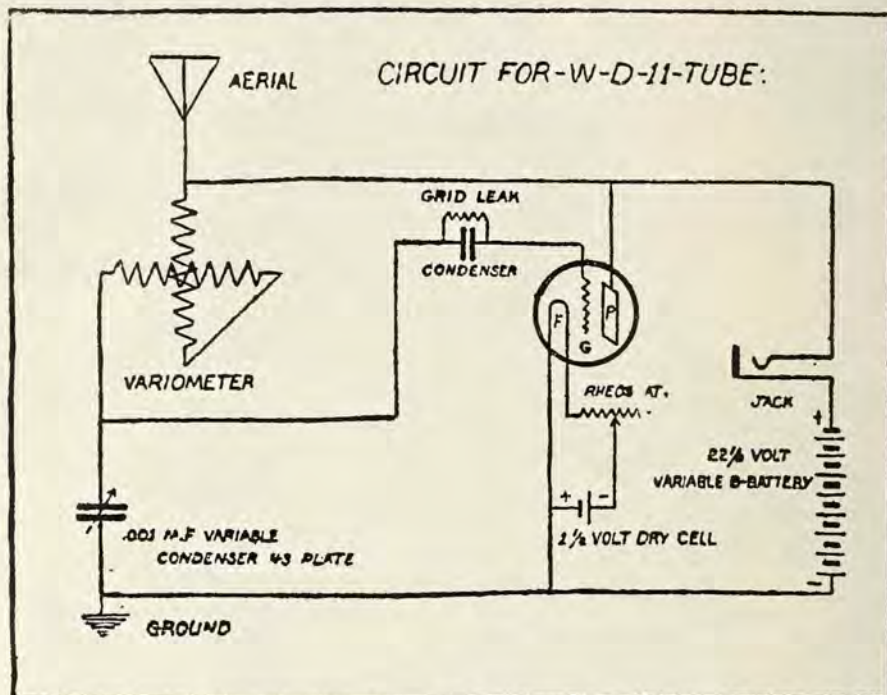

means that all the carbon terminals of the three batteries should be connected together and all the zinc terminals together, using the group of three cells as one battery. In this manner the volume of the current is increased three times, while the voltage remains at 1 1-2. If the batteries are connected in series, the tubes will be instantly burned out, so great care should be used to see that the batteries are correctly connected.

## Reinartz Tuner

(Continued from page 3.)

1 inch, which will bring them in far enough to make an efficient stop.

These contact points are to be spaced three-eighths of an inch apart, starting from the center one on each switch and spacing off with a lead pencil compass. Do not use dividers, as a slight slip will put an ugly mark on the polished surface of the panel, which cannot be erased.

The size of the holes given to accommodate the switch lever bearings is 5-16 of an inch. This is the size of most of them now on the market, but if one contemplates using some special make then the size should be changed accordingly. The two 5-16 inch holes shown below the switches are to be used for the shafts of the two condensers which are mounted directly behind them. The holes for the supporting screws of these condensers are not

shown for the reason that they are not all alike and the builder will have to locate these himself, after he decides what make of condenser he is going to use.

The three countersunk holes at the bottom of the panel are to be used for fastening a baseboard to the back of the panel, to support the coil, sockets, transformers, etc. This base board should be just long enough to fit in the cabinet (if one is used), about 8 inches wide and 1-2 inch thick, and should be of hard wood if possible. This will form a convenient shelf for the mounting of all of those parts which are not mounted on the panel.

The three groups of five holes each are for the purpose of forming a window through which the brilliancy of the filaments may be observed. They should be slightly counter-sunk as shown, and the tubes should be mounted directly behind them, with the radio frequency, or detector tube, to the left, as the case may be.

The three holes below these windows are for the shafts of the rheostats. Here again the holes for mounting have been omitted for the reason that their location will depend upon the particular type of rheostat used. The three holes below the rheostats are to be used for jacks, if desired.

# Adapting the Old Tuning Coil to the New W-D-11 Dry Cell Tubes

By F. D. PEARNE

THE new W-D-11 tube has caused many amateurs who have not been able to buy a storage battery to sit up and take notice. However, it is not always the lack of funds which prevent his having a tube set and battery, but very often the lack of proper facilities for charging it, when it runs down.

The fact that these new tubes will operate for several months on one cell of dry battery, has made them exceedingly popular, especially since they can be very nicely used in connection with some of the parts that were formerly used on the old crystal set. If one has either a one or two slide tuning coil on hand, it can be very easily adapted to this new circuit. This arrangement will give a much more efficient outfit at a very small additional cost. Because of the fact that this W-D-11 tube consumes only .2 amperes at 1.1 volts, it can be used on an average of one hour per day for about three months with one cell of ordinary dry battery.

These tubes have a different base than the Radiotron, or Cunningham type, hence the user will have to get the special socket which fits the tube. These, however, are not at all expensive.

In changing over the set to a tube set, the user will probably have an aerial already in use and a pair of head phones on hand and the additional apparatus required will be 1 W-D-11 tube and socket, 1 dry cell, 1 grid leak and condenser, 1 "B" battery having a voltage of 22 1-2, 1 rheostat, and 1 phone condenser. The rheostat is not absolutely necessary, but closer adjustments can be obtained if it is used. These parts should not cost more than \$8, which is a very small cost for a good tube set.

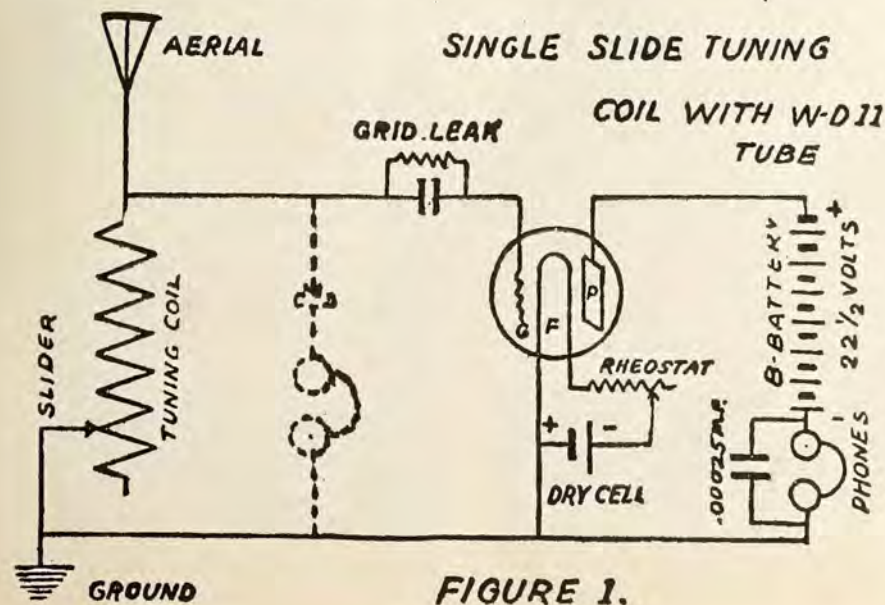

FIGURE 1.

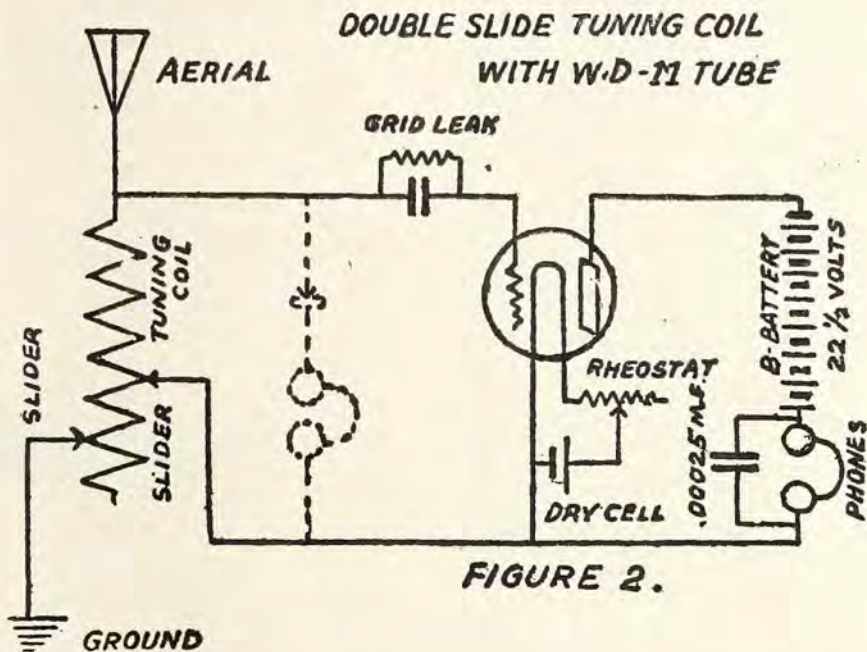

FIGURE 2.

The method of changing over a one slide tuning coil is shown in Figure 1. The crystal and phones shown in the dotted lines are to be omitted from the new set, when the new material is added. Connect one end of the coil to the aerial and grid leak with condenser and from there to the binding post, or connection on the socket marked "G." The post or connection marked "P" on the socket is next connected to the positive terminal of the "B" battery. The other terminal of the "B" battery is then connected to one side of the phones and the phone condenser. The other side of the phones and the condenser is connected

to the positive terminal of the dry cell as shown. The carbon terminal of the dry cell is the positive side. How the dry cell is connected in the filament and rheostat circuit is plainly shown in the drawing.

If the rheostat is omitted, then the negative terminal of the dry cell is connected directly to the filament, but some kind of a switch should be connected in the circuit so that the battery current may be shut off when the set is not in use. The positive terminal of the dry cell also goes to the ground and slider as shown. It is necessary that the "B" battery be of the "tapped" type, as the plate voltage will probably have to be varied, to obtain the best results, although the new and latest model of the W-D-11 tube work very well on 22 1-2 volts. Be sure that the "B" battery terminals are connected as shown, for a reversal of this order will give no results. The positive terminal must go to the plate contact on the socket.

The method of using a two slide tuner with this combination is shown in Figure 2. The only difference between this and the other circuit is that the wire which was connected to the slider and ground in the first instance is now connected to the second slider. The phone condenser used in both of these sets is the same, and is the standard .00025 phone condenser which is sold at all radio supply stores. It may be found that a condenser having a little more capacity may be used at this point, with better results. Either of these sets used in connection with a good pair of phones and a good aerial will give very good results.

## How to Make the Crystal Set Do Long-Distance Work

**A**N INTERESTING sidelight on the importance of the aerial design in attempting to get long distance results out of the crystal set is supplied by Frank X. F. Howe, of 504 Oakland Ave., Milwaukee, Wis. Mr. Howe holds the Milwaukee record for distance reception with the crystal set and has acquired considerable fame therefrom.

For the thousands of fans who are interested in crystal sets and in making them bring in the far stations we reproduce a diagram showing the arrangement of the aerial which Mr. Howe uses.

Mr. Howe writes us that for six months he has been experimenting with the aerial and with different kinds of crystals. He says these are the two vital factors in good crystal set reception. He found only one bit of crystal in a gross of crystals that would do the work he wanted it to accomplish. In this Mr. Howe is in accord with Mr. George C. Haseltine, of Fort Stockton, Texas, who wrote in the last issue of this magazine that he had made his remarkable long distance records because he paid special attention to his aerial and lead-in and used none but high class phones and crystals.

Mr. Haseltine, who has one record of 1,147 miles with a crystal receiver, says the aerial and lead-in must be well insulated, with all connections soldered. He uses the Million Point crystal.

Mr. Howe's aerial is an inside loop. He says it enables him to increase the strength of the incoming signals to the value obtained with the average vacuum tube set with one stage of amplification.

He uses a tapped coil instead of a slide tuner. The aerial is strung in an attic, fifty feet from the ground and is stretched in an east and west direction. It is made of No. 14 bare copper wire and is arranged as a rectangular loop. The length of this rectangle is 75 feet and the ends are six feet long. It is suspended in such a manner that one long side of the loop is above the other, making the short ends perpendicular. It thus contains one hundred and sixty-two feet of wire.

The lead-in wire is attached to the aerial, Mr. Howe explains, careful measurement being made to insure its being attached to the exact center. On one end of the loop there is a switch which is thrown

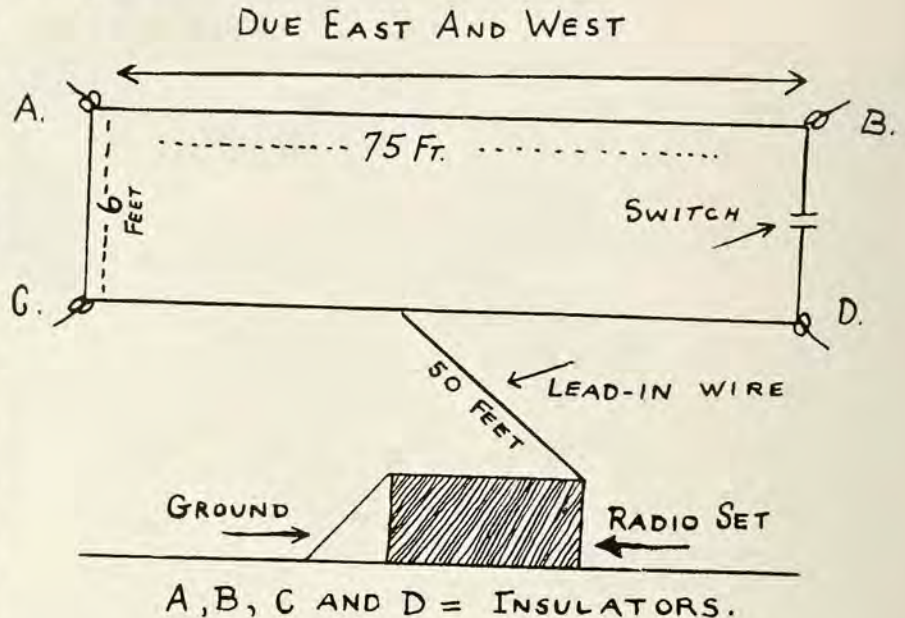

open when radio telegraph messages are being received. The lead-in wire is fifty feet in length and is the same size as the aerial wire.

Mr. Howe says the signals received with this hook-up are fifty per cent stronger than those received by any other arrangement he has seen or tested.

He also says that the same aerial, stretched north and south, was not satisfactory. This is a matter of experimenting as results might be different in different localities.

"This aerial arrangement was the result of an accident in some measure," says Mr. Howe. "I was experimenting with a vertically strung loop, open at one end, and I was changing the closed end of the loop to the other side of the loop. I got a reception, remarkably strong, before I could disconnect the perpendicular wire which I was trying to remove. I started to experiment, with the result described. I am sure the results obtained are due altogether to the style of the aerial as I have tested the crystal sets brought to me by friends and they have brought in the signals with great strength when attached to my aerial.

This hook-up enabled Mr. Howe to receive the program of Station WGL, of Philadelphia, about 1,000 miles distant. In getting this station, Mr. Howe used the aerial described, with vario-coupler, condenser and loading coil. (Description of how to make a loading coil

at small cost is published in the January-February issue of Radio Age.)

Mr. Haseltine calls attention to the fact that in his long distance work he uses a "small loose-coupler," properly wound.

Long distance reception with crystal sets is without doubt becoming more general. Those who have succeeded best with these efficient crystal set hook-ups have different ideas of what is necessary to accomplish the result. All of which shows that there is more than one way of making the crystal set do its work.

Frank D. Pearne, technical editor of Radio Age, had a very interesting article in the January-February issue of this magazine in which he demonstrated that all crystal sets receive signals from long distances, but that in a majority of cases the sets were not capable of sufficiently fine tuning to make these signals audible. He showed in that article that finer tuning could be obtained with the addition of a series condenser, a vario-coupler, variometer and fixed shunt condenser. The article has received a great deal of favorable notice.

Send in your crystal set records for publication and tell us about any novelties in hook-up, etc. Also let us know what difficulties you want straightened out in your crystal set hook-ups. Send self-addressed and stamped envelope with your query.



# "Wired Wireless" for the Millions

**R**ADIO without antennae and without storage batteries! Recent experiments have shown that it is possible to get your radio entertainment and information by plugging in on the electric light socket. This idea of General Squier has been discussed for some time but practical application of the method seems likely to be made for the benefit of millions of radio fans.

We publish in this issue not only an account of how "wired wireless" is to be brought into the homes of radio fans, but we tell how the Bureau of Standards of the Department of Commerce instructs owners of tube sets in applying this marvelous new development in radio to their own set. In this connection the Bureau of Standards diagram appearing on another page will be found highly interesting.

**W**ASHINGTON, D. C.—The demonstration of a new and unique method of communicating and broadcasting over electric light and power lines, by means of General Squier's system of "wired wireless, at the Bureau of Standards in Washington, indicates that within a short time all consumers of electric current may be able to plug in their radio sets to their lamp sockets and receive information and entertainment broadcast by the large light and power companies. The system is controlled by the North American Company of New York, which owns and operates the lighting utilities of Cleveland, Milwaukee, St. Louis and a number of other cities and which has secured an exclusive license under General Squier's patent rights for this purpose and is now developing the plan.

With the aid of a small condenser in series with vacuum tube receiving sets, or a special plug, consumers of electricity will be able to receive broadcasts from their electric wires just as they get "juice" to operate the flat iron, electric toaster or hair curler today. One button will produce "jazz," another news and a third grand opera, as soon as the power companies start broadcasting over their wire systems. The ether will in no way be disturbed by this sort of direct radio

broadcasting, and Secretary Hoover will not have to assign wave lengths or worry about interference with other stations using the ether; there will be no interference as the air is not used.

With the aid of a regulation broadcasting set at a sub-station of the Potomac Electric Power Company, messages were transmitted, January 8, over this company's lines, carrying 2,400 volts of alternating current, to the signal corps laboratory, Bureau of Standards in Washington, where they were received by means of a tube set coupled with condensers. The sending station was located at Georgetown. The wave which followed the wires was of 5,000 meters or 30,000 cycles and a transmitting current of 0.050 amperes was employed.

Following tests of General Squier's invention in Cleveland last May and further trials in New York in August, the North American Company concluded that a practical application of the system was of value and would permit the furnishing of an additional important service to lighting and power customers. Since October, R. D. Duncan, Jr., chief radio engineer of the company, has been perfecting the methods.

At the public demonstration made January 8 Mr. Duncan made the following statement:

"In cooperation with the Potomac

Electric Power Company, experiments have been under way for some time during which the voice has been transmitted over the high voltage lines of the latter company from the Georgetown and the Tennytown sub-stations and received at the Bureau of Standards and at different points in Chevy Chase and Maryland. This system of communication, referred to in the past as "wired wireless," is the invention of Major-General George O. Squier, at present Chief Signal Officer, U. S. Army, and consists essentially of substituting for the transmitting and receiving antennas of radio stations, the electric light wire network of a city. Instead of the high frequency energy being radiated through space in all directions as with radio, it is confined and directed to flow along definite paths from the transmitting station to the various receivers. During the recent experiments the two sets of transmitting apparatus were connected through special circuits to the 2,400 volt three-phase distribution system. The receiving apparatus was plugged directly into the light socket as is done with an electric iron, toaster or other familiar appliance.

"The broadcasting was carried on simultaneously with the normal operation of the electric power system, there being no interference with either system by the other."

## Voice Over High Tension Power Lines

**B**EFORE representatives of all the larger light and power companies of the United States, an amazing new use of radio was brought to light recently when it was demonstrated that voice conversations could be carried on by means of radio waves over high tension power lines, without the use of switches and just as are done in the ordinary telephone connection.

The test was carried out between

experimental stations located in the Colfax and Brunots Island power stations of the Duquesne Light Company, points located about thirty miles apart, by engineers of the Westinghouse Electric & Manufacturing Company and the power company. It was also demonstrated that this system could be used for remote control of all manner of apparatus.

For a long period of time the Westinghouse Company has been

working on a method of carrier current control for use in central power stations and electric railways, or other points using high tension electrical lines. The idea behind the whole scheme is to superimpose radio waves on the power lines and thus make use of radio transmitting and receiving for both voice communication and control of remote switches.¶

In this work the Duquesne Light Company has cooperated and pro-

vided experimental stations at its power stations in Brunots Island and Colfax, Pa.

Preliminary research work on ordinary transmission lines and feeder circuits had indicated that the use of wired wireless communication was simple and effective on such lines. But when trying out the Duquesne Light lines it was found that its system was complicated and extensive that many additional problems had had to be solved before it could be demonstrated that carrier current dispatching could be done successfully.

The members of the radio sub-committee of the National Electric Light Association, members of which are representative of all light and power companies of the United States decided to hold a meeting in Pittsburgh especially to see a demonstration of this revolutionary method of communication and control.

The test held Thursday afternoon, January 11, was entirely successful and demonstrated conclusively that this method interlacing the telephone with the power lines would soon be a feature in the plants of more progressive companies.

It was demonstrated in a small room of the power plant in Colfax,

where the committee had assembled, that the carrier current system of telephony allowing communication over high tension lines besides saving an additional right of way does away with the great noises and high induced voltages which operates so much dread in talking along lines that parallel high tension systems.

The new system was demonstrated over a 66,000 volt line and is unique in that the system is duplex and operates as does the ordinary telephone. When the telephone receiver is unhooked, the transmitting station automatically starts up, allowing talk in both directions without any switching. This feature is entirely new in radio as all other transmitting and receiving must be done by switching back and forth, because a station transmitting will not receive messages. The transmitting apparatus must first be switched off and the receiving circuit switched in. However, all this is done away with in the newest of systems.

The calling or ringing of numbers is selective and operated by special selector keys which cause the bell to ring only at the station desired. This eliminates the distractive code ringing and allows station operators

to keep their minds on their work.

The improved system developed by the Westinghouse Company has been carefully worked out by C. A. Boddie, radio engineer of the company and the technical and economic features are now being analysed by Mr. Boddie, assisted by M. W. Cooke, of the Duquesne Light Company.

The personnel of the committee witnessing the test was as follows: F. A. Allner, General Superintendent, Pennsylvania Water and Power Company, Baltimore, Md.; H. R. Searing, Superintendent Transportation, United Electric Light and Power Company, New York; L. W. Chubb, Manager of the Radio Engineering Department, of the Westinghouse Electric & Manufacturing Company; R. D. Duncan, formerly Chief Radio Engineer, U. S. Signal Corps, Washington, D. C.; E. P. Edwards, Manager, Radio Department, General Electric Company; G. A. Iler, Radio Expert, of Atlanta, Ga.; F. V. Magahaes, Superintendent, Testing Department, New York Edison Company; A. A. Meyer, Detroit Edison Company; and J. Morse, Shawington Water & Power Company of Montreal, Canada.

## How to Adapt Your Set to New Use

**T**HE Bureau of Standards of the Department of Commerce has developed in an experimental way a radio receiving set in which the usual batteries are eliminated, and connection is made instead to the ordinary electric lamp socket. The apparatus is an amplifier, which constitutes a receiving set when used with a simple tuner. It may be used with any type of antenna, i. e., with the ordinary elevated wire antenna, a coil antenna, or special forms of antenna.

The storage battery ordinarily required to light the filaments of the electron tubes is a drawback to the general use of radio sets. The battery must be charged from time to time; it is bulky and heavy, and the acid in it is a source of danger and damage in a household. In this amplifier both the filament storage battery and the dry battery used in the plate circuit are replaced by a special transformer and an electron-tube rectifier and accessories, the aggregate bulk and weight of which is less than that of the batteries.

It uses a small 10-volt dry battery in the grid circuit which is required to deliver only a very small current and should have a life practically equal to the life of the battery if

not used at all, i. e., at least several months. In order to reduce the hum of the alternating current, there are more adjustments to make than in the ordinary amplifier supplied from batteries.

Of the parts which in this amplifier replace the storage battery in the ordinary amplifier, the special transformer is the only one the cost of which would approach the cost of a storage battery. The cost of the transformer would probably be mainly the labor of assembling.

A statement was made in an early announcement of this amplifier that the storage battery is the most expensive part of the homemade radio receiving set. This may have been somewhat misleading, as the aggregate cost of the electron tubes in amplifiers, which employ several tubes, may exceed the cost of the battery. The cost of the battery, however, plus the cost of the usually necessary battery charging apparatus, generally exceeds any other item, even in an elaborate amplifier.

A few details of the amplifier, which utilizes 60-cycle current supply for both the filaments and plates of the electron tubes, are as follows: This amplifier has three radio-frequency stages and two audio-

frequency stages, and uses a crystal detector. The 60-cycle current when used in an ordinary amplifier circuit introduces a strong 60-cycle note in the telephone receivers and makes reception impossible. This has been practically eliminated by the balancing resistances, grid condensers and special grid leaks of comparatively low resistance, telephone transformer in the output circuit, and use of crystal detector instead of electron tube detector. In the final form of the amplifier, there is only a slight residual hum which is not objectionable.

The amplification obtained with ac supply was as good as that obtained with the same amplifier used with dc supply. The complete outfit is compact and portable. The amplifier as constructed operated most satisfactorily for wave lengths from 200 to 750 meters. This range was determined by the working range of radio-frequency transformers used. By using suitable radio-frequency transformers, this range can be extended to receive any radio waves.

The circuit diagram of the outfit, including the means of supplying current to a loud-speaking telephone receiver, is given in the illustration on another page.

# Amplifier Using Alternating Current

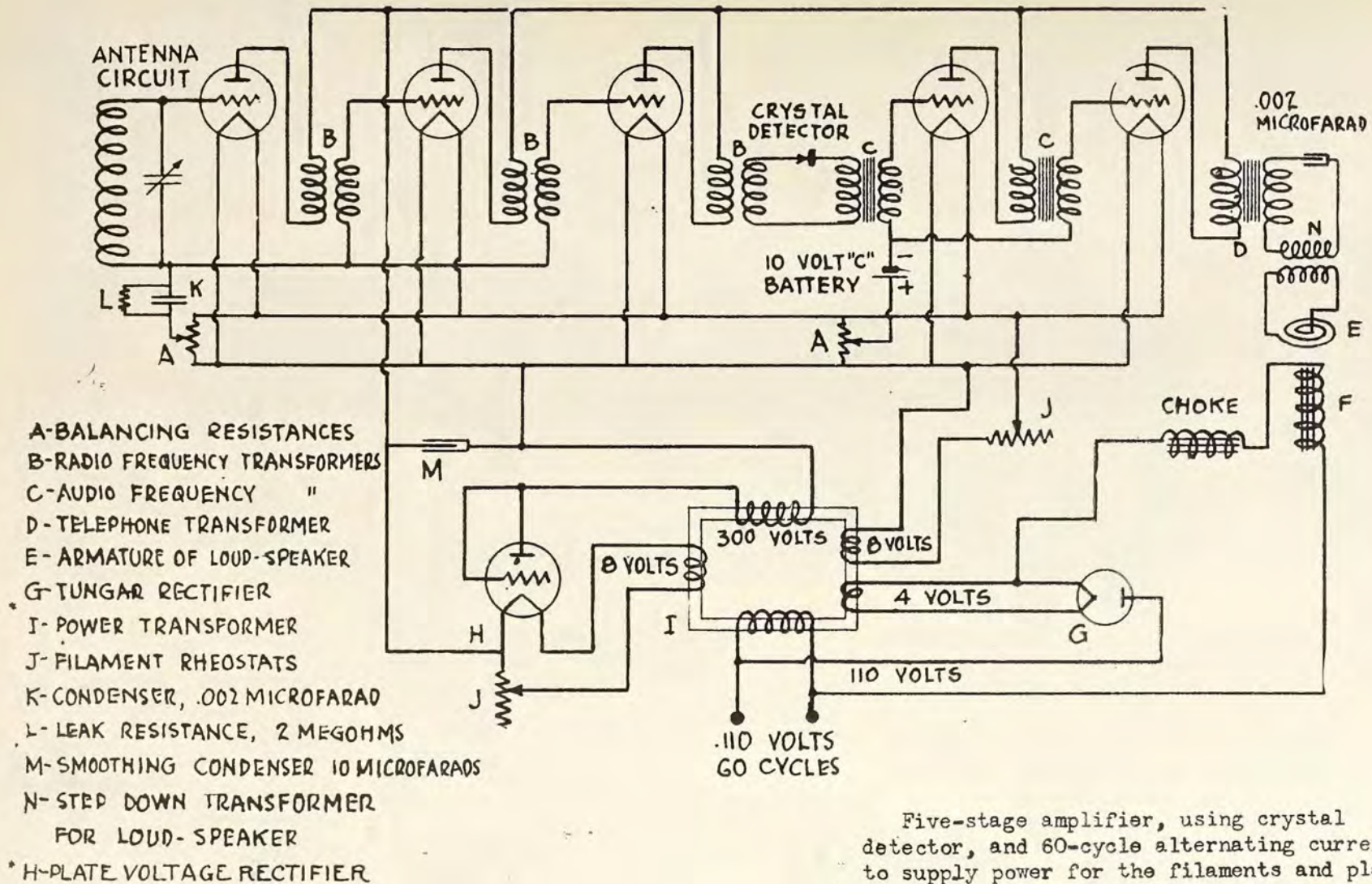

Five-stage amplifier, using crystal detector, and 60-cycle alternating current to supply power for the filaments and plates

# How to Make an Audio-Frequency Amplifier for Simple Set

(Bureau of Standards Circular 49)

## 1. Introduction.

MANY radio receiving sets include either a radio-frequency or an audio-frequency amplifier. A radio-frequency amplifier amplifies the radio-frequency signal before it is detected (rectified) by the crystal or electron tube detector, while an audio-frequency amplifier amplifies the rectified signal after it leaves the crystal or electron tube detector. The essential parts of either type of amplifier are the amplifier transformer and the electron tube.

This pamphlet describes an audio-frequency amplifier unit, that is, an amplifier employing a single electron tube. The detector may be either a crystal detector or an electron tube detector.

The amplifier unit is used by connecting it to the receiving set in place of the telephone receivers and then connecting the telephone receivers to the output of the amplifier.

The audio-frequency amplifier unit is aided to the tuner and detector so that the radio power received by the antenna may be transformed into sound in greater volume than would be possible by the use of a crystal or electron tube detector alone. The use of such an audio-frequency amplifier unit increases the receiving radius of the outfits described in previous pamphlets of the series approximately fifty per cent. Still greater receiving radius may be obtained by adding another amplifier unit just like the first one. It is usually not practical to use more than two stages of audio-frequency amplification—that is, two audio-frequency amplifier units.

One of these amplifier units added to a regenerative set increases the volume of sound in the telephone receivers.

Since a circuit including a crystal detector or simple electron tube detector will not make continuous-wave signals audible in the telephone receivers, the addition of an audio-frequency amplifier to these circuits will not accomplish this result.

The cost of this audio-frequency amplifier unit, complete with an electron tube, is between \$13.00 and \$21.00. This does not include the cost of batteries. If an electron tube detector is used in the receiving set, the same batteries are used for the amplifier unit. If, however, a storage battery for lighting the tube filament is not already available, this item will add from \$15.00 to \$22.00 to the estimate; and if dry batteries are not already available, the addition of two dry batteries for supplying voltage to the plate of the tube will add from \$2.00 to \$3.00 to this estimate. The cost of the tuner, crystal detector, telephone receivers and antenna equipment which are usually used with this amplifier is between \$11.00 and \$23.00. If the electron tube detector unit is used in place of the crystal

detector, the cost of the complete equipment is increased by an amount varying between \$7.00 and \$13.70.

## 2. Essential Parts.

A complete radio receiving station comprises:

*Antenna, lightning switch, ground connections and telephone receivers.* These are described in Bureau of Standards Circular, No. 120.

*Tuning Device.*—This is either the tuning coil described in Bureau of Standards Circular No. 120, or the two-circuit coupler and variable condenser described in Bureau of Standards Circular, No. 121, or any commercial tuning device which covers the required wave-frequency range.

*Detector.*—This is either the crystal detector arranged as shown in Bureau of Standards Circulars, Nos. 120 and 121, the electron tube detector unit as described in Bureau of Standards L. C. 48 or Circular No. 133, or some satisfactory commercial electron tube detector unit.

*Audio-frequency Amplifier Unit* (Figs. 1 and 3).—The audio-frequency amplifier unit is composed of a baseboard *BB* and an upright panel *A*. On the baseboard *BB* is mounted an electron tube socket *SS*, an audio-frequency amplifier transformer *T*, and eight binding posts. On the upright panel *A* is mounted a filament rheostat *R* (the adjusting knob *J* is shown in Fig. 3) and two telephone receiver binding posts *L* and *M*.

*Accessories.*—Under the heading of accessories may be listed a six-volt storage battery ("A" battery) having an ampere-hour capacity of about 60, used for lighting the electron tube filament, a 45-volt dry battery ("B" battery) for supplying the electron tube plate voltage, binding posts, stiff copper wire (tinned wire is usually preferred) wood boards for the baseboard and upright panel, two brass angle braces for supporting the upright panel, miscellaneous wood screws, and suitable stain and varnish. A composition insulating material panel is sometimes substituted for the wood panel and the amplifier unit enclosed in a wood cabinet with a hinged cover. When the cabinet is added the eight base board binding posts are left exposed.

*Baseboards (BB, Figs. 1 and 3).*—The base *BB* is any kind of dry, well seasoned wood about 6 1-4 inches by 8 1-4 inches by 1-2 inch thick. Eight holes are drilled through the base in which the binding posts are fastened. The binding posts are spaced so that they present a neat appearance or according to the dimensions given in Fig. 3, Bureau of Standards L. C. 48 or Circular No. 133. The baseboard is arranged so that the three remaining sides and a hinged cover may be added without changing the positions of the binding posts. Under each of the four corners of the baseboard

*BB* rubber or wood feet are fastened in order that the binding post heads and wiring on the under side of the baseboard will be protected.

*Upright Panels (A, Figs. 1 and 3).*—The panel *A* is any suitable dry, seasoned wood about 4 1-2 inches by 5 inches by 3-8 inch thick. In Fig. 1 a back view of the panel is shown which brings the two holes for the telephone receiver binding posts *L* and *M* in the lower left corner. (If the panel is viewed from the front these two holes will be at the lower right corner). This panel is made to present a good appearance, it being the front panel. Four holes are drilled in the panel *A*, one for the bolt which fastens the panel to the brace, (see *Z*, Fig. 1.) two for the telephone receiver binding posts *L* and *M* (Figs. 1 and 3) and one for the shaft of the filament rheostat *R* (See Fig. 1). The exact location and diameter of the hole for the rheostat shaft is determined from the rheostat itself. It is drilled so that the rheostat occupies as low a position as possible, allowing room enough to do the necessary wiring. Satisfactory upright panel measurements are given in Fig. 4 of Bureau of Standards L. C. 48 or Circular No. 133.

*Electron Tube (E, Fig. 3).*—The electron tube is a commercially available tube generally called an amplifier tube or "hard" tube. The several parts of an electron tube (sometimes called a vacuum tube) are described in "The Principles Underlying Radio Communication," Chapter 6.

*Electron Tube Socket (SS, Figs. 1 and 3).*—The electron tube socket is one of various commercially available types.

*Audio-frequency Amplifier Transformer (T, Fig. 1).*—The audio-frequency amplifier transformer is one of the various commercially available types.

*Binding Posts.*—The binding posts used on the baseboard are 6-32 or 8-32 brass machine screws each equipped with two nuts and two washers, if regular binding posts are not used. The telephone receiver binding posts, *L* and *M* (Figs. 1 and 3) are of the set-screw type to admit the tips of the telephone receiver cords.

*Filament Rheostat (R, Fig. 1).*—The filament rheostat is one of the various commercially available types designed for panel mounting and having a neat appearing knob and pointer. The rheostat has a resistance of about seven ohms and a current-carrying capacity of about 1 1-2 amperes.

*Accessories.*—The accessory batteries are commercial articles. The purchaser of the six-volt storage battery ("A" battery) for lighting the filaments should get full instructions from the dealer for testing and recharging the battery. The 45 V "B" battery usually used for the plate circuit can not be recharged. The normal life of a dry battery of reliable manufacture is about six months.

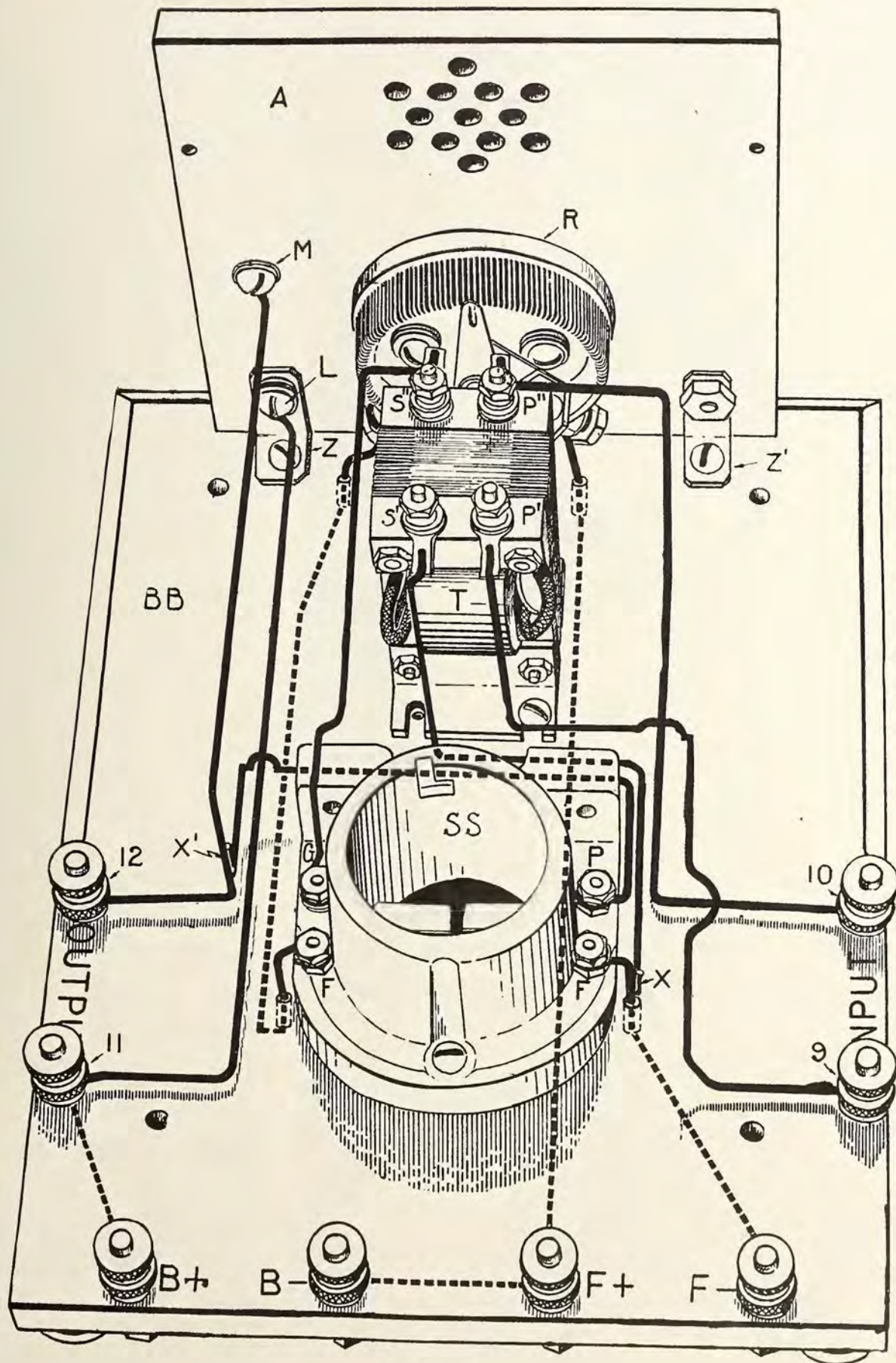

FIG. 1.

Storage batteries for use as "B" batteries are available. Their first cost is greater than that of dry batteries but they may be recharged.

Satisfactory dimensions for the brass angle braces are given in Fig. 1, Bureau of Standards L. C. 48 or Circular No. 133.

#### 4. Assembly and Wiring.

**Wood Finish.**—It is essential that the wood be protected from moisture. The wood is first dried, and then finished with stain and varnish; a good grade of varnish, preferably insulating varnish, is used. Shellac or other alcohol dissolved resins are not used. This method of wood finishing is found more satisfactory than treating with paraffin as described in Bureau of Standards Circular No. 120. The exact method of drying and finishing wood depends upon the condition of the wood itself. The wood is usually placed in a warm oven for an hour or so to insure more or less complete drying. The use of lamp black or carbon pigment stains is avoided, and the stain and varnish is thoroughly dried before the apparatus is mounted on the wood baseboard and panel.

**Baseboard** (Fig. 1).—The eight brass machine screws or binding posts are put in the holes already drilled in the baseboard. If machine screws are used the heads are put on the under side of the baseboard with a brass washer between the head and the baseboard. A brass washer and two nuts are then fastened to each screw, on the upper side of the baseboard, with the washer next to the baseboard.

The tube socket, *SS*, and the transformer *T* are next screwed to the baseboard. The exact location of these parts varies according to the particular type used. One can get an idea of the relative position of the several parts from Fig. 2. The tube socket *SS* is mounted so that the two terminals marked *G* and *P* (Fig. 1) are nearest the upright panel. Wood blocks are put under the socket *SS*, when necessary, so that the four terminals of the socket do not touch the wood baseboard. This is done by cutting off two round wood blocks just long enough to raise the socket terminals clear of the base, and mounting them so that the screws which hold the socket to the baseboard will pass through holes in the centers of the blocks.

After the socket *SS*, and the transformer *T* are mounted, the parts are wired. Number 14 bare (preferably tinned) copper wire is used in wiring. This makes the connections stiff and self-supporting. This wire is ordinarily furnished in rolls and is straightened before being used. This is accomplished by clamping or otherwise fastening one end of the wire solidly and pulling on the other end just hard enough to stretch the wire slightly. All wires are run as directly as possible, consistent with good spacing and neat appearance, and all bends are made at right angles. When a wire is attached to a binding post, a loop or eye is formed on the end of the wire and the wire at the eye flattened with a hammer. This gives more contact surface. Special lugs are sometimes

soldered to the ends of the wires before the connections are made.

A small hole is drilled through the baseboard near each of the tube socket terminals marked *F* (See Fig. 1). A short piece of wire is fastened to the right socket terminal marked *F* and is then led through the small hole in the baseboard to the under side of the baseboard. The same wire is led to the under side of the binding post marked *F* and fastened between the machine screw head and washer underneath the baseboard. All wires which are run on the underside of the baseboard, or are hidden by parts of the apparatus, are shown by dotted lines. A wire is soldered (at *X*) to the wire leading from the right socket terminal marked *F*, just above the baseboard, and led to the secondary terminal *S* of the transformer *T* and soldered or otherwise fastened thereto. This wire is shown as part solid and part dotted. The wires do not touch the wood boards except at the terminals and where the wires pass through holes in the baseboard. The wires may be raised more or less to accomplish this. Another wire is soldered to a primary terminal *P'*, of the transformer and led to the "input" binding post No. 9. Humps or bends are shown in this and other wires to indicate that the wires cross but do not touch.

A wire is soldered to the other primary terminal *P''* of the transformer *T* and goes from there to the other "input" binding post, No. 10. A similar wire reaches from the other secondary terminal *S''* of the transformer to the electron tube terminal marked *G*. The secondary transformer terminal, which connects to the terminal *G* of the electron tube socket, is that terminal which is internally connected to the outside of the secondary coil of the transformer. This is sometimes determined by inspection. In other cases it is necessary to try out the completed amplifier unit as described under "Operation." If good results are not obtained, the wire leading from *G* to *S''* is removed from *S''*, and connected to *S'*, and the wire leading from *X* to *S''* is removed from *S'* and connected to *S''*.

A wire connects the binding post *B+* and the "output" binding post, No. 11, on the underside of the baseboard. The remainder of the wiring is left until the upright panel is assembled and fastened to the baseboard.

**Upright Panel** (A, Fig. 1).—The filament rheostat *R* is mounted on the upright panel *A* so that the two terminals will be in a convenient position for wiring. Two binding posts of the set-screw, *L* and *M*, (Figs. 1 and 3) are inserted in their proper holes, and the upright panel mounted in position by bolting it to the two brass angle pieces (*Z* and *Z'*) shown in Fig. 1. One of the telephone receiver binding posts *L* serves as a bolt. Two small holes are drilled through the baseboard near the two terminals of the filament rheostat *R*. A wire is run from the "output" binding post No. 11 (Fig. 1) along the upper side of the baseboard to the back of the telephone receiver binding post marked *L*. A wire is fastened to the other "output" binding post (No. 12) and led to the rear of the

upper telephone receiver binding post *M*. A wire is fastened to the electron tube socket terminal *P* and led to some convenient point *X'* on the wire leading from binding post No. 12 to *M*. The wires are soldered together at this point.

A wire is run from one of the filament rheostat binding posts through the hole in the baseboard and thence along the under side of the baseboard to the binding post marked *F+* and is continued from *F+*, still underneath the baseboard, to the binding post marked *B-*. This wire is shown in Fig. 1 by a dotted line. Likewise a wire is run from the other rheostat binding post, underneath the baseboard and up through the left hole in the baseboard at the rear of the electron tube socket *SS* and connected to the left binding post marked *F*. This completes the assembling and wiring of the audio-frequency amplifier unit.

#### 5. Connections.

If the two-circuit tuner and the electron tube detector are used with the audio-frequency amplifier unit, the several parts are arranged as shown in Fig. 3. Two amplifier units are shown making a two-stage amplifier. If only one unit is used the connections are correspondingly simple. If a "hard" or amplifier tube is used in the electron tube detector unit, the connection *V* from the "B" battery is not used, but instead the wire *V* is connected to the binding post *B+* amplifier No. 1. Increasing the number of "B" batteries used to supply voltage to the plates of the amplifier tubes will usually increase the intensity or loudness of the amplifier radio signals, but at the same time the Quality of the tone will be impaired. The voltage should never be increased to as much as twice the rated plate voltage of the electron tube.

The two-circuit tuner and the tuning condenser *C* (shown at the left) are described in Bureau of Standards Circular No. 121. The location and wiring of the two additional binding posts, 5 and 6, on the baseboard supporting the tuning condenser *C*, are given in Fig. 6, Bureau of Standards L. C. 48 or Circular No. 133.

If the single circuit tuner and electron tube detector are used with the audio-frequency amplifier, the arrangement of the parts is also similar to that shown in Fig. 3 except that the single-circuit tuner (as described in Bureau of Standards Circular No. 120 and altered in Fig. 5, Bureau of Standards L. C. 48 or Circular No. 133) replaces the two-circuit receiving set. The binding posts, 5 and 6, on the single-circuit tuner are connected to the electron tube detector binding posts Nos. 1 and 2, respectively.

If the electron tube detector is not available, one method of connection is to use the audio-frequency amplifier with the single-circuit or the two-circuit radio receiving set shown in Bureau of Standards L. C. 48 or Circular No. 133. In this case the telephone receiver binding posts (+, Fig. 5, or *U*, Fig. 6, L. C. 48 or Circular No. 133) are connected directly to the amplifier "input" binding posts 9 and 10. The connections to the "A" and "B" batteries are the same as shown in Fig. 3 of this circular except that the wiring to the electron tube detector

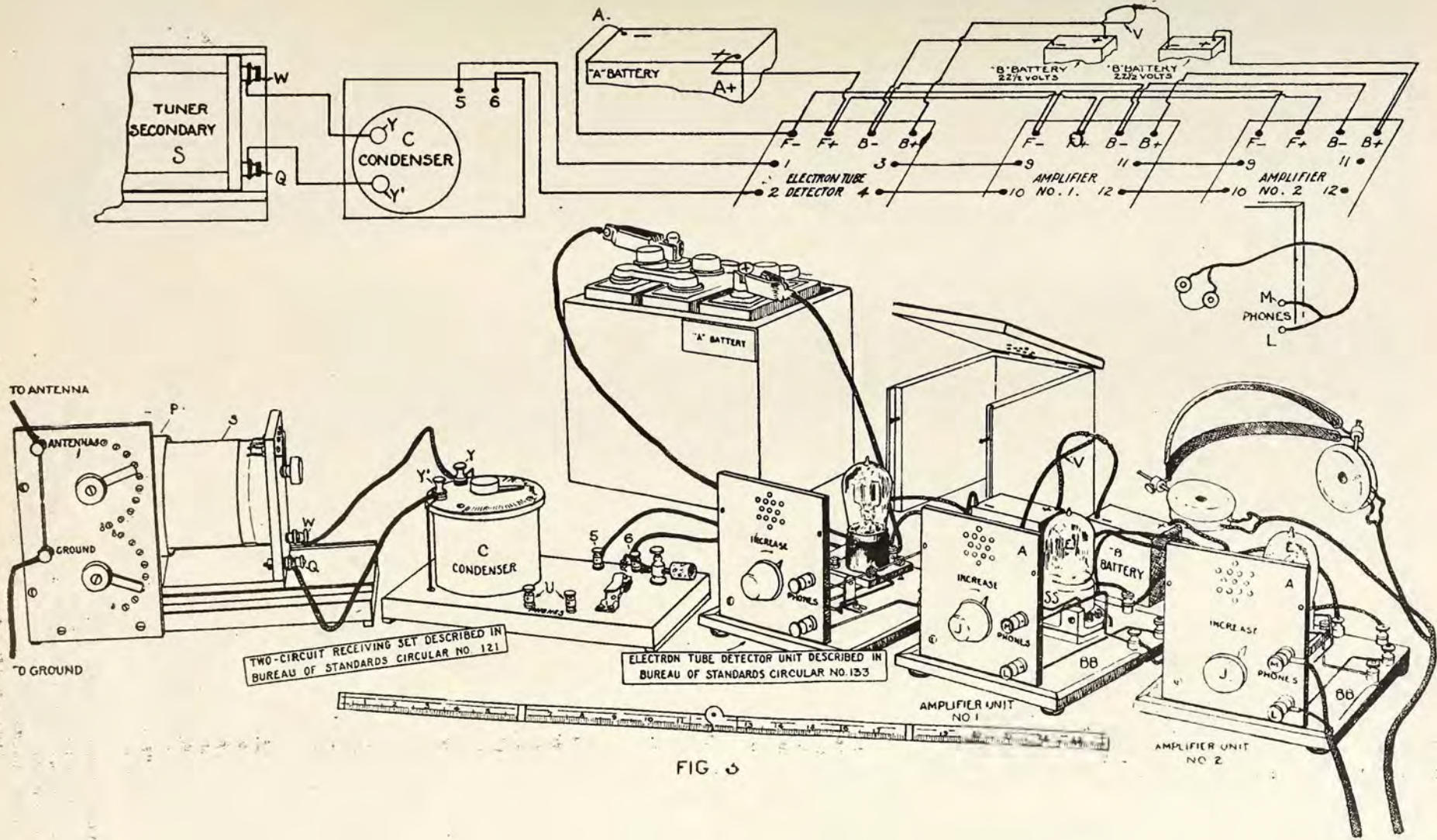

FIG. 3

is omitted. Great care is taken to see that the "B" or plate battery is not connected to the binding posts marked  $F+$  and  $F-$ . This battery has too high a voltage for the electron tube filament and will burn it out.

The antenna and ground wires are connected as described in Bureau of Standards Circular, No. 120, and as shown in Fig. 3.

To summarize, if the audio-frequency amplifier unit is used:

(1) with the two-circuit tuner and tuning condenser (circular No. 121) and electron tube detector (L. C. 48 or Circular No. 133), the connections are:  $W$  to  $Y$ ,  $Q$  to  $Y^1$ , 5 to 1, 6 to 2,  $A-$  to  $F-$ ,  $A+$  to  $F+$ , "B" battery— (black) to  $B-$  to  $B-$ , "B" battery connection  $V$  to detector  $B+$ , "B" battery— (red) to amplifier  $B+$ . 3 to 9, 4 to 10, 11 to 9, 12 to 10, and the telephone receivers to  $L$  and  $M$ .

(2) with the single-circuit tuner (Circular No. 120) and electron tube detector, the connections are: 5 to 1, 6 to 2 and so on as given in (1).

(3) with the two-circuit receiving set when the crystal detector replaces the electron tube detector, the connections, are:  $W$  to  $Y$ ,  $Q$  to  $Y^1$ ,  $U$  (right) to 9,  $U$  (left) to 10,  $A-$  to  $F-$ ,  $A+$  to  $F+$ . "B" battery— (black) to  $B-$ , no middle tap, "B" battery+ (red) to  $B+$ , and the telephone receivers to  $L$  and  $M$ .

(4) with the single-circuit receiving set when the crystal detector replaced the electron tube detector, the connections are:  $X$  (right) to 9,  $X$  (left) to 10, and so on as given in (3).

## 6. Operations.

The two filament rheostat knobs marked  $J$  (Fig. 3) on the two audio-frequency amplifier units, and also the filament rheostat knob on the electron tube detector unit, are turned to the extreme left or to the "off" position. Two electron tubes marked  $E$  ("hard" or amplifier tubes) are inserted in the sockets of the amplifier units (Nos. 1 and 2) and a third electron tube (preferably a "soft" or gas Tube) is inserted in the socket of the electron tube detector unit. The three filament rheostat knobs are then turned to the right until the filaments of the electron tubes become lighted, the brilliancy depending upon the type of electron tubes used. When one of the telephone receiver terminals is removed from its binding post (either  $L$  or  $M$ ) and again touched to the post, a sharp "click" in the telephone receivers will be an approximate indication that the circuit is in working condition. If the test buzzer, as described in Bureau of Standards Circular, No. 120, is available it is attached by a flexible wire to the binding post  $W$  on the two-circuit tuner, or if the single-circuit tuner is used, the test buzzer is attached to the binding post marked "Ground," to determine when the detector is in working condition.

The test buzzer is not at all necessary when the receiving set employs an electron tube for a detector, as the "settings" of the filament rheostats largely determine the operating condition of the receiving set after it has been tuned to the proper wave frequency (wave length).

When a crystal detector is used in place of the electron tube detector unit, a buzzer test is desirable to locate a sensitive point on the crystal.

When the crystal detector is not used the electron tube detector unit is merely substituted for it as shown in Fig. 3 and the tuning of the receiving circuit is the same as described in Bureau of Standards Circular No. 120 and 121. When the signals from a desired transmitting station are heard as loud as possible by tuning, the intensity is sometimes improved by adjusting one or more of the knobs on the filament rheostats so as to increase or decrease the filament current (current from the "A" battery). The knobs are kept in the positions of minimum filament currents without reducing the strength of the incoming signals.

## 7. Approximate Cost of Parts.

The following list gives the cost of parts of one Audi-frequency amplifier unit and the "A" and "B" batteries. It does not include the cost of the telephone receivers or any of the other equipment used to make up the outfits described in the previous pamphlets of the series. Some of the parts are the same as listed in the electron tube detector circular with some of the prices revised. If audio-frequency amplifier units are used, except that if a single "B" battery is used with the electron tube detector unit, one additional "B" battery is required.

Audio-Frequency Amplifier Unit.	
Electron tube ("hard", -amplifier).....	\$ 6.50- \$ 6.50
Electron tube socket .....	0.25 to 1.50
Filament rheostat.....	0.50 to 2.50
Audi-frequency amplifier transformer.....	5.00 to 8.00
Ten (10) feet No. 14 bare tinned cooper wire, about.....	0.10 0.10
Eight (8) binding posts, broad contact type .....	0.40 to 1.20
Two (2) binding posts, set-screw type (for telephone cord tips) .....	0.10 to 0.30
Miscellaneous wood screws, about.....	0.10- 0.10
Wood (hard, for base and panel).....	
One (1) piece 8 1-4x 6 1-4x1-2 inches.....	
One (1) piece 5x4 1-2x 3-8 inches.....	
Four (4) rubber feet, about.....	0.10- 0.10
Wood (for cover).....	
Two (2) pieces for sides 7 1-4x5x1-2 inches.....	
One (1) piece for back 5x3 3-4x1-2 inches.....	
One (1) piece for top 7 3-4x5 1-4x 1-2 inches.....	
Two (2) hinges for top, 3-4 inch.....	
Stain and varnish, solder, soldering flux.....	
	\$13.05 to \$20.30

## Batteries.

"A" storage battery, 6-volt, 60-amperehour .....	\$15.00 to \$22.00
Two (2) "3" batteries 22 1-2 volts each .....	2.00 to 3.00

Total.....	17.00 to 25.00
	30.05 to 45.30

If the electron tube detector unit is equipped with a "soft" or "gas" tube, the voltage of the "B" battery is changed until the greatest signal intensity is obtained. This necessitates the use of a tapped "B" battery. This means that the wire  $V$  (Fig. 3), instead of connecting to the wire which connects the two "B" batteries, is provided with a clip which is connected to successive tapped terminals on one of the "B" batteries until the required voltage is obtained.

When two audio-frequency amplifier units are used a continuous "howl" is sometimes produced in the telephone receivers. In this case the wires leading to the "input" binding posts of one or both of the amplifier units are reversed, that is, binding post 3 is connected to binding post 10, and 4 to 9, and binding post 11 of an amplifier No. 1 to binding post 10 of amplifier No. 2 and also 12 to 9.

In case the apparatus fails to operate the trouble may be attributed to a variety of causes. An inspection is first made of the various parts of the receiving equipment to determine if they are properly connected, special care being taken to see that the positive (+) and negative (-) terminals of the "A" battery are connected respectively to the binding posts marked  $F+$  and  $F-$ , and that the positive (+, red) and negative (-, black) terminals of the "B" battery are connected respectively to the binding posts marked  $B+$  and  $B-$ .

To determine if the various parts of the receiving circuit are in working condition the telephone receivers are removed from the "phone" binding posts on the amplifier unit and connected to the "phone" binding posts on the crystal detector receiving set. The wires connecting to binding posts 5 and 6 (Fig. 3) are temporarily removed and the fine coiled wire brought in contact with the crystal. The receiving set is then adjusted as described in Bureau of Standards Circular No. 120 or 121. This furnishes a means of ascertaining if the tuner is in working condition and also the crystal detector, although the latter is of course not used with the electron tube detector and amplifier units unless the electron tube detector unit is omitted.

The wires are now reconnected to the binding posts 5 and 6 and the telephone receivers are connected to the "phone" binding posts on the electron tube detector unit. One of the wires which is connected to one of the "output" binding posts of the electron tube detector unit is temporarily removed and tests made to determine if the electron tube detector is in working condition.

The telephone receivers are next connected to the "phone" binding posts on amplifier No. 1, the wire reconnected to the "output" binding post of the electron tube detector unit, and one of the wires disconnected from one of the "output" binding posts (11 or 12) of amplifier No. 1. Tests are then made to determine if amplifier No. 1 is in working condition.

The telephone receivers are then removed from amplifier No. 1 and attached  
(Continued on page 27.)



# Pick-Up Records by Our Readers

Irving Frisch, 923 East Thirty-first street, Brooklyn, writes:

Your September number fell into my hands and I must say that the occasions are few and far between when I have seen such an interesting magazine. You are to be congratulated on it. I built the Reinartz set described in that number and the first night I tried it on a single tube I received WHB, Kansas City; KYW, Chicago and PWX, Cuba. Since then I have heard WLAG, WCX, WGM, WSB, WOO, WIP, WFI, WGY, WDAC, KSD, WOC, KDKA and WJAX.

F. P. Foulk, 1114 Olney Street, Indianapolis, Ind., writes that he has received the following stations since Christmas: KSD, KYW, KDKA, PWX, WBX, WCX, WGY, WHB, WJH, WLK, WLW, WOC, WOH, WOR, WPA, WRW, WSB, WGM, WWJ, WAAF, WBAJ, WBAP, WCAE, WDAF, WFAA, WHAS, WJAX, WKAN, WLAG, WMAQ, WMAX, CFCA, WIAO, WOO, WDAJ.

Mr. Foulk adds that his set consists of a WD 11, 1-1-2 V tube, a variable condenser and a home-made vario coupler. He uses no variometers or amplifiers. A truly fine showing.

Harold J. Brown, 223 W. Walnut street, Vicksburg, Mich., writes that he noticed in Radio Age the Reinartz records of Mr. Bisnak and Mr. Anderson. Mr. Brown also made a set and he reports having heard the following stations: WOC, WSB, WGM, WDAJ, WNAC, WHK, KOP, WWJ, KDKA, WGY, WJZ, WHB, WDAF, KYW, WFAA, WBAP, KSP, WGA, WIAR, WGF, WCAE, WOI, WIAO, WGAM, CJCG, WMAQ, WOS, WBAJ, WLW, WIAF, WCX, WHAS, WHAM.

Mr. Brown says "I have a detector with no amplification and it sure does work well."

V. A. Mattingley, 2917 1/2 East Thirty-fourth Street, Kansas City, Mo., writes:

"I see Mr. W. G. Lehr of Chicago has a good Reinartz set and I want to tell you about mine. I have a 43-23 and 3 plate condenser, three bulbs and thirty foot aerial. I hear California nearly every night and have heard KPO on one bulb. Here is a list of stations I heard in two nights: WBAD, WFAA, KPO, KFI, KFBB, PLPG, WHAZ, KSU, WDAP, WBAP, WAAK, KFCE, WOAZ, 9XU, CKGM, CFSE, KYW, WABJ, WOI, WGM, KHJ, WAAC, WDY, WGY, WKN.

"I have a vario-coupler and two variometers hook-up but that hook-up will not bring in anything like my Reinartz set. In tuning I have a wire from my ring on my little finger connected with the ground wire. It helps."

Lyle Penna, 1113 Maple avenue, Terre Haute, Ind., also challenges Mr.

Anderson's record. Writing on January 10 Mr. Penna reports receiving sixty stations since December 16. He has received the principal stations in a score of states, including Minneapolis, Newark, San Antonio, Washington, D. C., Atlanta, Denver and three stations in New York state. Mr. Lyle uses a home-made set with a condenser, coupler, and detector with two stages of amplification. His aerial is twenty-five feet high, consists of two wires and is one hundred feet long. We congratulate Mr. Penna on having such a long string of scalps that we have not room to publish them all.

Hubert Kurtz, Chillicothe, Mo., writes: "I read Mr. W. G. Lehr's 'pick-up' record in the last issue of Radio Age. I thought I would let you know of the results I am having with my set. I completed my set about the middle of last month and, from January 1 to January 15, I picked up the following stations: WGY, WDAI, WHB, WDAF, WMAJ, WOQ, WOS, WLAG, WLAJ, WPA, WBAP, WOC, KDKA, WGM, WWJ, WRR, WHAB, WJAJ, WHAS, WLK, WLW, WAAP, WMAQ, WLAL, WQAQ, WJAT, WKAC, WCAR, WKY, KLZ, KSD.

My aerial is twenty-feet high and seventy-five feet long. I use one step of amplification and can hear all the stations very distinctly."

Russell Thomas, 4524 W. River Drive, Minneapolis, Minn., writes:

"In the February issue of Radio Age I noticed a letter signed by Mr. W. G. Lehr, who asked some person with a variometer-vario-coupler radio set to try to 'shoot' his record. I am leaving it to him if he doesn't think I have broken his record. Although I am using a variable condenser-vario-coupler set I think I am still qualified for the challenge. I am enclosing a diagram of my set. You will notice that the negatives of each group of 'B' batteries are paralleled and that this is connected to the negative rather than the positive of the 'A' battery.

"On Friday, January 26, from 8:00 to 8:30 p. m. and from 10:00 p. m. to 1:00 a. m. I picked up the following stations: CFCA, WCX, WCAE, KYW, KSD,

KDKA, WGY, CKCK, WBAP, WGM, WIP, WSB, WEAC, WJD, WLAL, KLZ, WPAC, WDAF, WJZ and WGV. On January 27 from 8:00 to 8:45 p. m. and from 11:00 p. m. to 1:00 a. m. I picked up stations: KOP, WSB, WOC, KYW, WCAE, WCM, KSD, WCAL, WFAA, WDAP, WDAF, CFCN, WJAX, KFI and CFCA. On December 10 at 7:45 p. m. I heard station WKAQ at San Juan, Porto Rico, and on December 16 between 4:00 and 6:00 p. m. I received stations: WMAT, WDAP, WHAS, KOP, WHK, WOS, WCAE, WJAT and WOR.

These results may be due to my aerial, which consists of two wires each two hundred feet long and fifty feet from the ground, running from northeast to southwest. I think my set has more to do with it than the aerial since I have heard KYW and a number of other stations using a light socket for an aerial and my regular aerial as a counterpoise ground."

Over 3,576 miles per hour is the distance covered by radio by Robert H. Anthony, 18 Cleveland Road, Needham, Mass. This speed was maintained December 30 and 31 over a period of six hours and twenty minutes. Among the cities visited (by radio) were San Francisco and Long Beach, Calif., Roswell, N. Mexico, Colorado Springs, Dallas and Fort Worth, Texas, and Havana, Cuba, not to mention such nearby communities as Milwaukee, Chicago, St. Louis, Atlanta, Birmingham, etc.

The broadcasting of all these cities and many more, totaling forty-five in all, was received during fourteen hours and twenty minutes operating time on the evenings of December 24, 25 and 30, and the early morning of December 31. The total number of miles covered during this time was 39,345, which establishes Mr. Anthony's claim to a Radio Golf of high rank.

Higher Radio Golf cards may have been turned in, but it is believed this is a record considering the time of play. "Radio Golf" is a new game invented by Frank Jones of Tuinucu, Cuba. It is a gentleman's game. Each one keeps his own score. A record is kept of the broadcasting stations heard. A broadcasting station can only be computed once. The mileage between the broad-

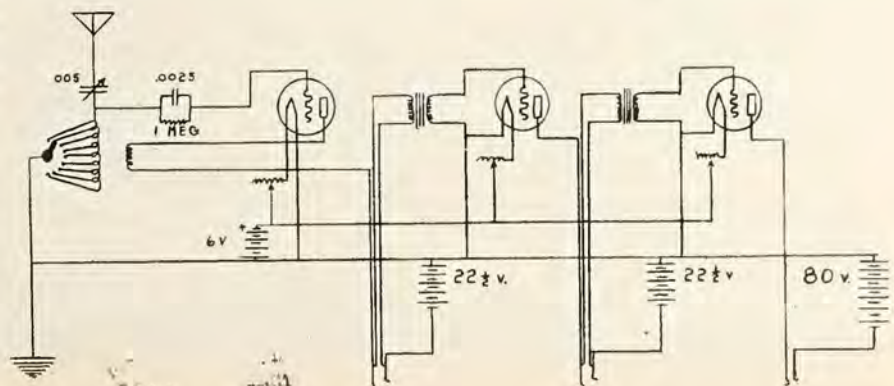

casting station and the radio receiving set is computed from the map and the various distances added up.

Mr. Anthony is New England Manager for R. Thomas Sons Co., manufacturers of electric porcelains. The equipment with which he made this phenomenal record was a receiver, employing one stage of radio frequency, and two stages of audio frequency amplification. San Francisco was heard clearly through a loud speaking horn.

Listed below is Mr. Anthony's score card:

December 24, Three Hours Play.		Miles
WAAK	Milwaukee	920
WIP	Philadelphia	290
WOC	Davenport, Ia.	1,035
WGY	Schenectady	87
WRR	Dallas	1,610
WDAC	Springfield, Ill.	1,006
WHK	Cleveland	575
WHB	Kansas City, Mo.	1,294
WQAA	Parkersburg, Pa.	317
WJZ	Newark	201
WHD	Morgantown, W. Va.	544
WAH	Eldorado, Kansas	1,438
Local Stations		15
		9,332

December 25, Five Hours Play.		Miles
WJZ	Newark	201
KYW	Chicago	892
WHD	Morgantown	544
WJAX	Cleveland	575
WGY	Schenectady	87
WWJ	Detroit	633
CFCF	Montreal	259
WBZ	Springfield, Mass.	66
KSD	St. Louis	1,092
WOO	Philadelphia	290
WYJ	Los Angeles	2,712
Local Stations		10
		7,361

December 30-31, Six Hours, Twenty Minutes Play.		Miles
WEAF	New York City	201
WGM	Atlanta	978
WIP	Philadelphia	290
KDKA	Pittsburgh	489
WFI	Philadelphia	290
PWX	Havana	1,571
WAAK	Milwaukee	920
KSD	St. Louis	1,064
WRR	Dallas	1,610
WKM	Memphis	1,179
WPA	Ft. Worth, Texas	1,639
WDAC	Chicago	892
KHD	Colorado Springs	1,869
WMAF	So. Dartmouth	64
KNJ	Roswell, N. Mex.	1,984
KSS	Long Beach, Calif.	2,703
WSB	Atlanta	978
KDN	San Francisco	2,818
WSY	Birmingham, Ala.	1,093
Local Stations		20
		22,652

Grand Total—39,345 miles in 14 hours and 20 minutes.

W. M. K. Young, 414 New York Life Building, Kansas City, Mo., writes:

"I am using a Reinartz circuit and one stage of amplification, and want to tell you of its accomplishments.

"Last night I heard:

- WCX Detroit, Free Press
- WWJ Detroit, News
- WHAS Louisville, Ky., Courier Journal
- WOS Jefferson City, Mo., State Mkt. Bureau
- WJAE San Antonio, Texas, Texas Radio Corp.
- KSD St. Louis, Mo., Post Despatch
- KJR Seattle, Wash., N. W. Rad. Service Corp.

"All of these stations were heard without having any ground wire connected to my set, using a hundred foot aerial and I did this while WDAF, The Kansas City Star, was broadcasting their regular program and they are only twenty city blocks from me. If there is anyone who can beat this, we will be glad to hear from them.

"I have repeatedly heard the following stations and am giving air line mileage obtained by measuring from Kansas City to the station named on the map with ruler:

KJR	Seattle, Wash.	1,582
PWX	Havana, Cuba	1,769
KDN	San Francisco	1,433
KHJ	Los Angeles	1,305
WCN	Worcester, Mass.	1,172
WGY	Schenectady, N. Y.	1,065
WRL	Schenectady, N. Y.	1,065
KFDD	Hanford, Calif.	1,278
WOR	Newark, N. J.	1,050
IXAE	Springfield, Mass.	1,136
CFCN	Calgary, Can.	1,225
CJCG	Winnipeg, Can.	746
CFAE	Toronto, Can.	855
WGM	Atlanta, Ga.	650
WSB	Atlanta, Ga.	650
WCX	Detroit	635
WWJ	Detroit	635
WMAK	Lockport, N. Y.	852
KDKA	Pittsburgh, Pa.	746
WHAS	Louisville, Ky.	480
WLW	Cincinnati, Ohio	527
KLZ	Denver, Colo.	560
DNA	Denver, Colo.	560
KFAF	Denver, Colo.	560
WJAE	San Antonio, Texas	705
WOAI	San Antonio, Texas	705
WCAE	Pittsburgh, Pa.	746
WDAJ	Collegeport, Ga.	652
WRR	Dallas, Texas	416
WLAG	Minneapolis, Minn.	416
WFAA	Dallas, Texas	416
KYW	Chicago, Ill.	400
WDAP	Chicago, Ill.	400
WLK	Indianapolis, Ind.	453
WBAP	Ft. Worth, Texas	456
WPA	Ft. Worth, Texas	456

Miles  
28,757

"These stations come in clearly and I heard complete programs from nearly every one of them. I have also heard CFCB Vancouver, B. C., 1,710 miles, and WLAY, Fairbanks, Alaska, 3,160 miles, but only once.

"I do not believe that the above distances covered can be improved upon very much when only using one stage of amplification. Please consider these distances in your record contest. Total, including Vancouver and Alaska, 33,627 miles."

Trevor Lakin, Anderson, Ind., writes: "I noticed in your last issue that W. G. Lehr, of Chicago, reported some records. I am not a knocker but I wish to tell of a small record I made recently. I shall not take time and space for all of them. Here are a few: WMAV, KFI, KWH, KHJ, KPO, KGU and KDXY (Honolulu) KFAJ, KLZ, KFAF, KOA, PWX (Havana) CFCN (Calgary, Can.) CKCK (Regina, Saskatchewan, Can.) CHYC and CFCF (Montreal, Can.) KOB (State College, N. M.) KNJ, WCAK, WEAF, WEAY, WCAR, WOAI, CJGG (Winnipeg) WHAB, WDAL, WJAR. I have one-tube Reinartz set. It is constructed altogether differently from any hook-up I have ever seen. In fact, it is original. I have heard 204 stations, not counting CW or spark. My aerial is a cage type, about 25 feet high at one end and thirty at the other."

Mr. Lakin will be talking to Australia next.

Drew MacDougal and Teddy MacDougal, of Nichols, Iowa, write: "We have subscribed to Radio Age and think it is a fine magazine. We are specially interested in your pickup records. Our

set is a non-regenerative, single circuit set with a homemade loose coupler and no amplification. Here are some of the stations we get regularly: WGY, WBZ, KDKA, CFCB, CJCA, WLAL, WEAF, WJZ. Here are some we have received several times: WMAF, KWH, KFQ, WAAC, KFDF, CFCN, CKCK, WFAH, WGI, WOR, WFI. Of course we get Chicago, Atlanta, Omaha, Denver, Dallas, Fort Worth, Indianapolis, etc., all the time. We get KHJ at Los Angeles every night. We have received 115 stations in twenty-seven states and four provinces in Canada. We have also heard Denver with a crystal set and nine other stations. We would like to see some of these records in your magazine if they are good enough. We say they are good enough.

## KDKA Breaks Record

Broadcasting a concert 5,000 miles is the proud record of KDKA, the radio-phone broadcasting station of the West-

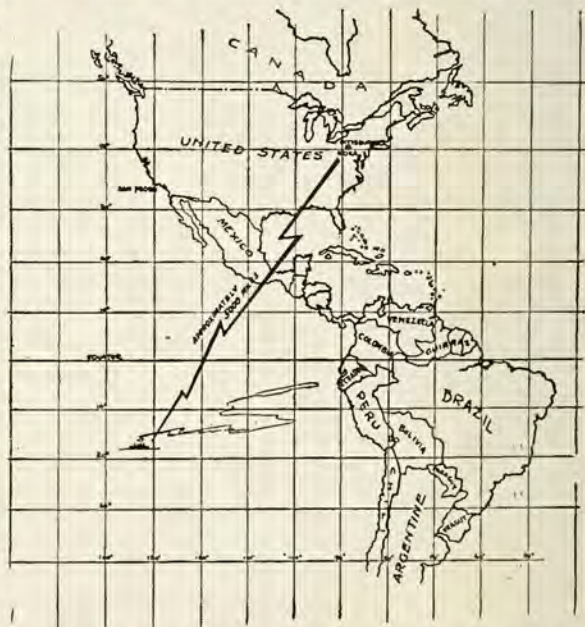

Map shows the distance the radio waves traveled in carrying KDKA's concert to a ship off the coast of Peru.

inghouse Electric & Manufacturing Company, located at East Pittsburgh, Pa., which is the real pioneer broadcasting station in the country.

This latest achievement of KDKA, which first started operating November 2, 1920, and which, by its continuous operating, started the world off on the radiophone craze, was brought to the attention of the Westinghouse broadcasting officials upon the receipt of a postal card from E. G. Osterhoudt, radio operator of the SS. "J. A. Moffett" in which he tells of hearing KDKA while off the coast of Peru, a distance of approximately 5,000 miles.

Send \$1.00 to Radio Age, 64 Randolph Street, Chicago, and receive this middle-west radio periodical for six months. Regular subscription price is \$2.50 per year.

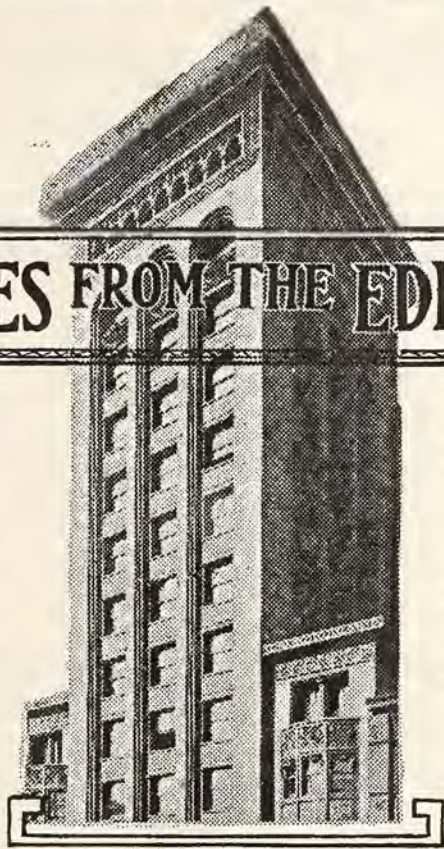

# THOUGHT WAVES FROM THE EDITORIAL TOWER

**Y**E EDITOR was listening in the other night when transmission conditions seemed ideal. Slight turns of the rheostats brought pleasing proof that stations all the way to the Atlantic coast were trying to greet him, chat with him, play music for him, sing for him.

Alas! There was a high official of our government in town who was scheduled for a speech to a convention of business men. Ye editor did not want to hear a long talk about business and government. It is a dry subject at best and it requires the genius of an orator to make it passably entertaining. Anyhow, ye editor had plenty of newspapers and magazines at hand where-in he could find such topics ably discussed if he cared for them.

That high government official talked and talked. The newspapers the next morning boiled his speech down to a few paragraphs and they would not have given him more than a stickful if he had not been a high government official.

It seemed to ye editor that the broadcasting station that transmitted the speech could learn something from the newspapers. A speech that is too dull to print certainly has no place on the air for a two-hour period.

While we are grouching about this, let us say three words about soprano solos, long sermons, and extremely classical piano renditions. Make 'em snappy.

Evening is the time for wholesome recreation. Those hours between dinner and bedtime are the precious radio hours. They should be filled with variety, vivacity.

Of course we know that the instructions are to tune out the undesirable and tune in something else. For the thousands who depend upon crystal sets this is a funereal jest. For the many other thousands who have invested in tube receiving sets incapable of tuning out a 400 meter station almost within sight of their aerials it also is a bit of irritating advice.

Ye editor does not wish to be misunderstood. He likes a good sermon in season, is charmed by good singing and nothing pleases him more than a speech by a man whose logic gets all ablaze and makes him eloquent.

But there is a great difference between speeches, sermons and songs. A speech is not necessarily broadcastable simply because it is a speech and the speaker has been elected to something. A song, poorly sung, is as painful as a soft corn and a long sermon proves that the clergyman is not visibly impressed with the example of the Nazarene, who was the greatest Preacher of them all.

In short, broadcasters should be careful to give the fans what the fans want and not what the broadcaster thinks the fans ought to want. And it is a man's job to do the one and avoid the other. Station WDAP has the thing pretty well reasoned out.

Ye editor, however, has no brief for a western friend, who listened in on a particularly highbrow program of Bach and Browning and business until he lost patience, disconnected his A battery and shouted into the throat of the loud speaker one ungentlemanly word, "Beaver!" Now what did he mean by that?

**U**NDER the terms of the White Radio Bill, recently passed by the

House, the Secretary of Commerce is authorized to refuse to grant licenses to those applicants who seem to be monopolizing or seeking to monopolize radio service. We hope the Senate will not modify this provision and that Secretary Hoover will never hesitate to use this explicit authority. If any of the big companies enjoying monopolies in their various communities in dispensing of electrical service, ever make a definite effort to gobble up the sport of millions there will be a popular howl that will need no amplification to make it audible.

Radio justly belongs to the people. Let it stay in the hands of the people. To those who are weary of our warnings against radio monopoly we say only that we have been sounding such warnings for a year and we have only started.

**I**T IS with the greatest pleasure that we call attention to the sportsmanlike attitude adopted by amateur radio transmitters as represented particularly by the Relay League. The amateurs have recognized that their messages threatened to interfere with satisfactory reception of broadcasting programs and they have bowed to the wishes of several millions of fans and arranged their own transmitting conditions in such a way as to minimize interference. These amateur radio telegraphers were the pioneers in American wireless and their surrendering of their former freedom in their beloved avocation involves a sacrifice that every radio fan should recognize and gratefully acknowledge.

Secretary Hoover says he doesn't care who controls radio, and is willing to turn it over to the Interstate Commerce Commission if Congress so decides, but he does insist that some regulations be enacted into law and that some one be put in charge to relieve the interference, handle licenses, and assign the waves.

The Director of Radio, or whatever his title may be, will have his hands full controlling the waves, it is pointed out by one fiend on history, who recalls that Old King Canute got into difficulties some years ago and wet his feet terribly trying to do the same thing.

Despite the general use of radio and the millions of fans informed as to the reception of broadcasts, some remain ignorant of possibilities. The other day, in the National Press Club, one member suggested that the set be "speeded up," saying the music coming in was "too slow."

# Radio Bill Held Up By Senate

(Special to Radio Age)

*As this issue goes to press it appears unlikely that the Kellogg-White Radio Bill, which was passed by the House recently, will be passed by the Senate this session. If the Senate does not act in this session, it means that radio must wait at least until next December for relief by legislation.*

**W**ASHINGTON, D. C.—With the passage of the White bill by the House of Representatives, broad powers have been vested in the Secretary of Commerce in regulation and supervision of radio broadcasting. Radio owners are jubilant because at last there is to be a new allocation of wave lengths, which, it is hoped, will eliminate overlapping of programs and interference with good reception. The bill is now in the Senate, where its progress will be followed with keen interest.

The Secretary of Commerce not only will have control of the wave lengths designated to each station but he will have the power to regulate the periods occupied by the programs of each station.

Licenses will be required from all transmitting operators excepting government employes. Army and Navy and other government stations, although exempt from the license provision, will be required to conform with the rules when handling commercial or other non-government business.

Assigning of wave lengths for the government stations will be in the hands of the President. The bill provides for an Advisory Committee consisting of men appointed by various department heads, radio experts and amateurs, to keep abreast of developments and needs of the radio industry.

Amateur receiving stations will not come under the regulatory provisions of the bill and amateur sending stations will have a special series of wave lengths assigned to them.

One encouraging provision in the bill is the explicit declaration against monopoly and the steps it outlines for preventing any of the super-corporations from seizing control of the industry. Under this law the Secretary of Commerce is directed to refuse licenses to any applicant, if it appears that the granting of those licenses would tend to assist a monopoly.

Representations were made to the House Committee on Merchant

Marine, which had the bill in charge, that monopoly of radio service might be obtained by the Radio Corporation of America, headed by General Harbord and backed by the General Electric Company and by the J. P. Morgan interests.

The Radio Corporation, it was represented, might control the air through obtaining patents on devices and exclusive rights to certain bands of wave lengths. Thus, it was pointed out, the corporation might actually control all radio service for a foreign nation to the United States.

Even if the Secretary of Commerce should grant a license to an applicant "monopolizing or seeking to monopolize radio communication" the United States would not be estopped from prosecuting a licensee for "violation of the law against monopolies or restraint of trade."

One misunderstanding arose as to the interpretation of the section of the bill relating to the licensing by the Department of Commerce of all operators who handle commercial traffic. Many of the Naval ship and shore stations and some of the Army's transports and stations in Alaska now transmit commercial messages in public interest, when there are no other means of forwarding them by radio or wire. A strict interpretation of the bill would require that Army or Naval operators who handled such messages be licensed by the Department of Commerce, and Secretary Hoover stated at the hearing that the Navy should not have privileges denied other users of wireless. He agreed, however, that he and Secretary Denby would confer on the matter.

## White Seeks to Placate Hoover and Denby.

As a result of an executive session, Chairman White waited upon Secretary Denby and Secretary Hoover Saturday with a plan of compromise on the licensing of naval and military operators and the control of Army and Navy stations. An agreement between the Department heads was accomplished.

Both Army and Naval officials point out the fact that if their operators were forced to take the commercial examinations, it would handicap their work, necessitate considerable travel and split authority over them. It would also complicate grades in the services, as today the Navy has several classes of operators, the Army only two, while there are three grades of commercial licenses. On the other hand, the Department of Commerce has not the funds or personnel to examine all the operators of the two military services, many of whom are scattered all over the world; they want

only a compliance with regulations and fair competition in commercial work. Signal Corps officials would regret the necessity of having to handle commercial work, explaining that they do so only when no other means of communication is available. This is the case in the Navy, too; the Department is most anxious to get rid of its commercial work, although it is glad to aid in transmitting messages from out-of-the-way places. Recently eight Navy stations were closed, but on request two were re-opened. If Navy men had to be licensed as commercial operators, Secretary Denby said he would refuse all future commercial traffic.

Commenting on the situation, Secretary Hoover said that the point of disagreement with the Navy was not a wide one, and he was willing to compromise in the interest of the public. The bill, he explained, was intended to control only those radio transmitting stations carrying on a regular commercial or broadcasting service, and to license their operators.

The bill, which was passed by the house on Wednesday last, has been transmitted to the Senate, where it awaits assignment to a committee.

When the bill is assigned, early action is still hoped for, although some Senators admit that if it is likely to incur much debate and obstacles are thrown in its way, it will be impossible to pass it this session.

Secretary Hoover, after a conference with Senator Kellogg, was sanguine as to the bill's passage in the Senate this session, unless some obstructionists interfere.

Based upon the present number of stations and operators and at rates now set forth in the bill, the Department expects to collect annually a sum approximating \$186,000 in fees for licenses. Amateurs will pay a considerable portion of this. This would offset a large part of the expenses of administering, inspecting and licensing the stations and individuals. This money would not be received in cash by the radio section of the Department but would be collected through the sale of Government revenue stamps and would constitute additional income to the Government. Thus, it is explained radio interests and individuals would actually be paying for supervision and service, which would require almost double the work.

The bill does not carry any salaries for the members of the Advisory Committee, who are not Governmental employes, but provides for the payment of their expenses when in session in Washington. One of Secretary Hoover's first acts, it is understood, following the passage of radio legislation, would be to secure the appointment of this committee and call a session for the immediate revision of the wave assignment schedule.

*The Monthly Service Bulletin of the*  
**NATIONAL BROADCASTERS' LEAGUE**

Solely by, of and for Radio Broadcasting Station Owners

George S. Walker  
Western Radio Corporation  
Denver, Col.  
President

Arthur E. Ford, E. E.  
State University of Iowa  
First Vice President

W. J. Baldwin, W S Y  
Alabama Power Co.  
Birmingham, Ala.  
Second Vice President

Frederick A. Smith  
Garrick Building,  
Chicago  
Secretary

Founded to promote the best interest of Radio Broad-  
casting stations in the United States and Canada.

Executive Offices, Garrick Building, Chicago, Ill.

DIRECTORS:

T. B. Hatfield, W O H  
President Hatfield Electric Co.  
Indianapolis, Ind.

S. W. Place, W B A G  
Radio Engineer,  
Diamond State Fibre Co.  
Bridgeport, Pa.

T. W. Findley, W L A G  
President and Genl. Mgr  
Findley Electric Co.  
Minneapolis, Minn.

Stanley O. Need, W G A H  
The New Haven Electric Co.  
New Haven, Conn.

Earle C. Anthony, K F I  
Earle C. Anthony, Inc.  
Los Angeles, Cal.

Howard E. Campbell, W W J  
The Detroit News,  
Detroit, Mich.

A. J. Westland, W W L  
Physics Dept. Loyola University  
New Orleans, La.

J. Elliott Jenkins, W D A P  
Midwest Radio Central, Inc.  
Drake Hotel, Chicago, Ill.

H. A. Trask, K S D  
St. Louis Post Dispatch  
St. Louis, Mo.

Frank W. Elliott, W O C  
Palmer School of Chiropractic  
Davenport, Ia.

SIXTEEN broadcasting stations have joined the National Broadcasters' League since the last list published. It is noticeable that all the stations coming into the organization are of the progressive class. Their letters indicate that they are keenly interested in the continued high character of broadcasting and ever watchful lest any action be taken which would tend to interfere with the truly important service the transmitting stations are performing for the radio millions.

The list of new members follows:

WCAJ, University Place, Nebraska, Nebraska Wesleyan University.  
 KSD, St. Louis, Mo., The St. Louis Post Dispatch  
 WSY, Birmingham, Ala., Alabama Power Co.  
 WCAU, Philadelphia, Pa., Durham & Co., 1936 Market Street.  
 WLAQ, Kalamazoo, Mich., A. E. Schilling.  
 WHAH, Joplin, Mo., Hafer Supply Co., John T. Griffin.  
 W2AA, Parkersburgh, Pa., Horace A. Beale, Jr.  
 WLK, Indianapolis, Ind., Hamilton Manufacturing Co., 2011 North Alabama Street.  
 WOOA, Ardmore, Oklahoma; Dr. Walter Hardy.  
 WAAZ, Emporia, Kans., Hollister-Miller Motor Co.  
 WFAB, Syracuse, N. Y., C. F. Woese.  
 WHAD, Marquette University, Milwaukee, Wis.  
 WNAC, Boston, Mass., Shepard Stores.  
 WMAQ, Chicago, Ill., The Chicago Daily News, 15 North Wells St.  
 KGB, Tacoma, Wash., Tacoma Daily Ledger, H. F. Higgins.  
 KFAF, Denver, Col. Western Radio Corporation, George S. Walker, 1627 Champa Street.

The secretary suggests that all members of the League write to the secretary,

Frederick Smith, Garrick Building, Chicago, outlining their views on the allocation of wave-lengths, the question of fees for copyrighted music, etc., the difficulty in obtaining needed equipment on the open market and expressing their wishes in connection with any other matters that will come to the attention of the Secretary of Commerce at Washington under the new radio bill which has just been passed by the House at Washington.

Now is the time to act in concert. It is certain that Mr. Hoover will not fail to pay attention to communications from an organization of broadcasters representing big stations in most of the states of the union. Send along your letters and they will be transmitted to Secretary Hoover in a manner that will impress him with our earnestness of purpose and with our desire to cooperate in the difficult task that is being assigned to him.

The recent conference on standardization, held in New York under the call of the Bureau of Standards, Department of Commerce, took no definite action regarding the standardization of "service," which means broadcasting. The details of this standardization of broadcasting will necessarily command the attention and the vital interest of every man in the broadcasting field.

Members should write to the secretary, giving their views on broadcasting, its difficulties and its needs. This correspondence will be sent forward to the committee of radio engineering institutes which have practically the disposal of these questions, in cooperation with the Secretary of Commerce and with the radio manufacturers, dealers, amateurs, radio-owners, commercial transmitters, broadcasters of entertainment, etc.

Such correspondence presented *collectively* will convince the committee chiefs and the officials at Washington that the National Broadcasters' League is an aggressive, live organization that

knows what it wants and wants nothing but the good of radio and radio service.

Send on your letters. Don't wait for the other fellow to make suggestions. Each individual opinion is needed and now is the time to make our wishes known. We have an important organization. Let's go.

The following appears in the Radio Service Bulletin of January 2, 1923, issued by the Bureau of Navigation of the Department of Commerce:

"Broadcasting Stations Violating Section 2 of the Act of August 13, 1912.

"Operators of broadcasting stations are cautioned not to communicate with other stations. The transmission of acknowledgments to individuals relating to the receipt of letters, telegrams, and telephone calls is direct communication and not authorized in the licenses of broadcasting stations. Section 2 of the Act of August 13, 1912, states that the license of a station "shall state the purpose of the station," and as broadcasting stations are licensed for the specified service of broadcasting, any operator using a broadcasting station for point-to-point communication may have his license suspended or revoked in the discretion of the Secretary of Commerce. Owners of broadcasting stations should see that the above-cited act is not violated as the use of their stations for purposes other than specified in the station license is sufficient cause for the suspension or revocation of their station license."

For the first time since broadcasting began in September, 1921, fewer new stations were licensed during January than dropped out, indicating that the field for broadcasting is practically filled. This is not to be wondered at, officials point out, because the "saturation point" has been reached.

Today, there are 570 broadcasting stations, 28 of which are in the B class on

400 meters, the balance being on the more popular 360 meter wave. On January 1 there were 576, showing a loss of six during the month. While there were 28 new stations licensed in January, 34 old ones failed to renew their licenses.

On the first of February, last year, there were but 36 stations licensed in the new pastime of broadcasting—today there are almost 16 times that number. Many people believe that this is far too many, particularly since they are not well distributed on the 360 meter wave. The radio bill, however, provides for the distribution of a large number of new waves, which will aid in decreasing the interference. Competition is creeping into the game. The best equipped stations giving the best service to the fans will become the permanent ones in the long run, it is believed.

## Sale of WDAP

WDAP, the popular station established by Thorne Donnelley and J. Elliott Jenkins under the company name of the Midwest Radio Central, Inc., and situated on the top floor of the Drake Hotel, Chicago, has been taken over by the Chicago Board of Trade.

Chicago being the center of the world's grain markets, the acquisition of this powerful station by the Board of Trade is an important radio item. It marks another step in the advance of radio into the important position wireless is assuming in commerce.

Announcement of the change in ownership was made on January 16. Following is a verbatim report of how the announcement was made:

"This is WDAP, now the official broadcasting station of the Chicago Board of Trade, located on the Drake Hotel, operated by the Midwest Central Radio, Inc.

"We shall now broadcast a few remarks to be made by the retiring president of the Chicago Board of Trade, Mr. Robert McDougal, during whose term of office the negotiations were made through which the Chicago Board of Trade will own this station.

"WDAP wishes to say to its friends that Messrs. Donnelley and Jenkins will continue to operate this station as in the past, so far as entertainment programs are concerned, under the direction of the Chicago Board of Trade Radio Committee.

"We announce Mr. Robert McDougal, retiring president of the Board of Trade of the City of Chicago.

Mr. McDougal said:

"This is certainly an unique experience. No former officer of the Chicago Board of Trade has ever greeted our patrons and friends in this manner, and I am very happy indeed to speak to those I cannot see on this epoch-marking occasion.

"My message to those interested in the commercial activities, centering on the Chicago Board of Trade, is brief. In this miracle manner we shall, as during the past few months, give to the entire radio public the official prices and other valuable information in connection with all commodities handled through this channel, thus serving the public from the

farmer to the ultimate consumer. We hope to broaden our acquaintance, and demonstrate our proclamation that the Chicago Board of Trade is an open book that he who runs may read, and that prices are not made behind closed doors and available only to the few.

"The complete ownership and operation of this station will bring to our association, as such, no financial return; but we hope it will work to the mutual advantage of the members and their world-wide clientele.

"Nothing but authoritative facts and figures will be broadcasted on the commercial side, but we hope to enter the more human side of life through concerts as well as instructive addresses, which will be constructive as well, and we hope that the Chicago Board of Trade Radio Committee may have the pleasure of hearing from listeners who believe as we do—that this is a step forward in our endeavor to acquaint the public, in the grain business and out, with the operations of the world's greatest grain exchange and the largest international enterprise located in the Middle West."

The editor of Radio Age has received a letter from the Radio Committee of the Board of Trade further setting forth the aims of the Board as follows:

"Briefly stated, the policy of the Board of Trade for broadcasting station will be that of service and entertainment—service of the strictest, yet broadest character, to those who are interested in any phase of the grain business or other activities centering in this exchange.

"The entertainment feature will be of a dignified sort and as high a grade as possible, believing that we can in this way sell the idea that the Board of Trade of the city of Chicago is not an institution without a soul.

"Sticking absolutely to figures and facts, allowing no market opinion to be expressed and permitting no member of the Board of Trade, save the President and Secretary as officials, to go on the air, giving addresses from time to time through country-wide respected men and giving the radio public the best there is in the way of entertainment in the evening, with ball scores in season, will be our endeavor. There will be an iron clad rule against anyone going on the air, through this station, that would tend to reflect lack of dignity or discredit upon the Board of Trade or serve any individual member or firm in the way of advertising.

"It may be interesting for you to know that we received a letter from Hannibal, New York, stating that Mr. McDougal's address was heard very distinctly and enjoyed. It develops that Mr. McDougal's grand-parents and great-grand-parents are buried in that town. So you can easily see that there is in it an interesting coincidence."

## Ten Naval Radio Stations Closed

Secretary of the Navy Denby has directed that four Naval radio stations be sold, four others abandoned, and two radio compass stations be closed and

dismantled. In carrying out the recent recommendations of the Rodman Board in the interests of increasing fleet efficiency, particularly in communication, the Secretary is disposing of unnecessary radio stations.

The stations at Cape May, N. J., will be closed and abandoned by Naval personnel at once, its work hereafter being handled by the station at Cape Henlopen. At Seattle, another station will be abandoned as soon as the Navy Yard at Puget Sound can take over the traffic. Grande Isle in Louisiana has been ordered closed and abandoned, as has also the station at Navassa Island in the West Indies.

Radio stations at Baltimore, Md., Mobile, Ala., Miami, Fla., and Port Arthur, Texas, will be offered for sale as soon as invitations for bids can be drawn up. It is also planned to dispose of the station at Managua, Nicaragua, when commercial facilities are provided at that place.

The War Department has been asked if it desires to take over any of the ten naval radio stations on the Great Lakes, but it is not likely that the Signal Corps will accept any except those at Buffalo and Cleveland. Such stations as the Army does not take over will remain closed. Radio compass stations at Pass a Loutre, La., and St. Petersburg, Fla., will be dismantled and the land vacated by the Navy. Several other stations are being held subject to abandonment as soon as the handling of existing traffic is arranged.

In closing the stations, the Navy Department does not desire to interrupt traffic in radio, but, on the other hand, as commercial traffic was only handled when other facilities were lacking, officers are of the opinion that commercial interests may now be induced to open general traffic stations at points previously covered by the Navy. The prime purpose of Naval shore radio stations is to aid the fleet, and when a station ceases to benefit the fleet, it becomes a liability to the Government instead of an asset.

## Weather Forecasts

Additional weather forecasts and warnings will be broadcast from NAT, the Naval Radio Station at New Orleans, commencing on January 1. These broadcasts, on a wave of 1,832 meters are for the district included in Louisiana, Arkansas, Oklahoma and Texas, and comprise weather forecasts, river conditions, and a summary of the conditions over the United States twice daily. The schedule calls for a broadcast at 10:30 a. m. and 10:00 p. m. at 75th meridian time.

The Naval Communications Service has doubled its radio commercial rates. After April 1, all Naval stations requested to handle commercial messages will charge at the rate of twelve cents a word. It is hoped that this will relieve the department from further criticism. Emergency commercial service will be continued, however, where there are no other facilities.

# Corrected List of U. S. Stations Alphabetically by Call Signals

## Complete Each Issue

THE list of broadcasting stations on these pages is brought up to date each month by additions of new stations and deletion of those which have suspended operation. The list is the product of a vast volume of correspondence and its completeness is due in large measure to the assistance of our special news service in Washington, D. C. Suggestions, corrections and additional data will be welcomed from readers.

IXAD, Pawtucket, R. I. 300 and 600 meters; 1000 miles; Special license experimental; Standard Radio & Electric Co.  
 KJKA, E. Pittsburgh, Pa.; Class B station, up to 485 meters; Westinghouse Elec. & Mfg. Co.  
 KJN, San Francisco, Calif.; Leo J. Meyberg Co.  
 KDDW, Steamship America, New York.  
 KUPM, Cleveland, Ohio; Westinghouse Elec. & Mfg. Co.  
 KDPT, San Diego, Calif.; Southern Elec. Co.  
 KDVL, Salt Lake City, Utah; news music, entertainment, Telegram Publishing Co.  
 KDVM, San Diego, Calif.; Nevada State Journal, Nevada Machinery & Electric Co.  
 KDVS, Portland, Ore.; Oregon Inst. Technology.  
 KDYS, Great Falls, Mont.; Class B, 485 meters, Great Falls Tribune.  
 KDYY, Salt Lake City, Utah; Cape & Cornwall Co.  
 KDYZ, Phoenix, Arizona; Smith Hughes & Co.  
 KDYA, Honolulu, Hawaii; Honolulu Star Bulletin Co.  
 KDZA, Tucson, Ariz.; Arizona Daily Star.  
 KDBZ, Bakersfield, Calif.; Frank E. Seifert.  
 KDZE, Seattle, Wash.; Rhodes Co.  
 KDZF, Los Angeles, Calif.; Automobile Club of Southern California.  
 KDZH, San Francisco, Calif.; Cyrus Pierce & Co.  
 KDZG, Fresno, Calif.; Fresno Evening Herald, Class B, 845.  
 KDZI, Wenatchee, Wash.; Electric Supply Co.  
 KDZK, Reno, Nev. Wednesday 8 to 9 p. m.; Friday 8 to 9 p. m. Musical and news features; Nevada State Journal, Nevada Machinery & Electric Co.  
 KDZL, Ogden, Utah; Rocky Mountain Rad. Corp.  
 KDZM, Centralia, Wash.; E. A. Hollingworth Co.  
 KDZQ, Denver, Colo.; Motor Generator Co.  
 KDZX, San Francisco, Calif.; Glad Tidings Tabernacle.  
 KDZZ, Everett, Washington; Kinney Bros. & Sippell.  
 KFAO, Phoenix, Ariz.; Class B, 485, McArthur Bros. Mercantile Co.  
 KFAE, Pullman, Wash.; State College of Washington.  
 KFAF, Denver, Colorado; George S. Walker. Western Radio Corporation; musical programs, news items, etc., daily except Tuesday and Sunday, 8 to 9 p. m.; mountain standard time.  
 KFAJ, Boulder, Colo.; University of Colorado.  
 KFAK, Moscow, Idaho; Electric Shop.  
 KFAF, Butte, Mont.; Standard Pub. Co.  
 KFAQ, San Jose, Calif.; City of San Jose.  
 KFAH, Hollywood, Calif.; Studio Lighting Service Co.  
 KFAI, Reno, Nev.; Reno Motor Supply Co.  
 KFAJ, Eugene, Ore. Monday, Wednesday and Saturday 8 to 9 p. m. Music; Sunday 8:30 to 9:15 Church Services; Pacific Radio Co.  
 KFAU, Boise, Idaho; Class B, 485, Boise High School.  
 KFAV, Venice, Calif.; Abbott Kinney Co.  
 KFAW, Santa Anna, Calif.; Class B, 485, Radio Den.  
 KFAZ, Central Point, Ore.; W. J. Virgin Milling Co.  
 KFB, Reddley, Calif.; C. H. Weatherill.  
 KFBH, Havre, Mont.; F. A. Buttry & Co.  
 KFBG, San Diego, Calif.; W. K. Azbill.  
 KFBH, Hanford, Calif.; California Radio Lab.  
 KFBH, San Louis Obispo, Calif.; R. H. Horn.  
 KFBG, Tacoma, Wash.; First Presbyterian Church.  
 KFBH, Marshfield, Ore.; Thomas Musical Co.  
 KFBK, Sacramento, Calif., 2,000 miles; daily, 3 to 4 p. m. and 6 to 6:30 p. m.; Sunday and Thursday 8 to 9 p. m.; Kimball-Upton Co. and Sacramento Union.  
 KFB, Everett, Wash.; Leese Bros.  
 KFB, Laramie, Wyo.; N. S. Thomas.  
 KFB, Colorado Springs, Colo.; Clarence O. Ford.  
 KFCB, Phoenix, Ariz.; Nielson Radio Supply Co.  
 KFCO, Wallace, Ida.; Auto Supply Co.  
 KFCO, Salem, Ore.; F. S. Barton.  
 KFCF, Walla Walla, Wash.; Frank A. Moore.  
 KFCG, Billings, Mont.; Elec. Service Station.  
 KFCO, Colorado Springs, Colo.; Colorado Springs Radio Co.  
 KFCM, Richmond, Calif.; Richmond Springs Radio Co.  
 KFCP, Ogden, Utah, Ralph W. Flysare.  
 KFCV, Houston, Tex.; Fred Mahaffey, Jr.  
 KFDA, Baker, Ore.; Adler's Music Store.  
 KFED, Billings Polytechnic Institute, Polytechnic, Mont.  
 KFDB, San Francisco, Calif.; Mercantile Trust Co., also 400.  
 KFDE, Boise, Idaho; St. Michael's Cathedral.  
 KFDS, San Francisco, Calif.; John D. McKee.  
 KFEB, Taft, Calif.; City of Taft.  
 KFCQ, Casper, Wyo.; Motor Service Station.  
 KFDL, Denver, Colo.; Knight Campbell Music Co.  
 KFDD, Corvallis, Ore.; Oregon Agri. College.  
 KFDC, Spokane, Wash.; Radio Supply Co.  
 KFDF, Casper, Wyo.; Wyoming Radio Corp.  
 KFEC, Portland, Ore.; Meier & Frank Co.  
 KFEL, Denver, Colo.; Winner Radio Corp.  
 KFEP, Denver, Colo.; Radio Equipment Co.  
 KFFA, San Diego, Calif.; Dr. R. C. Shelton.  
 KFFL, Los Angeles, Calif.; Los Angeles Union Stock Yards.  
 KFFI, Tacoma, Wash.; Guy Gresham.  
 KFFE, Pendleton, Ore.; Eastern Oregon Radio Co.  
 KFFQ, Colorado Springs, Colo.; Markshoff Motor Co.  
 KFGG, Astoria, Ore.; Astoria Budget.  
 KFGH, Stanford Univ., Calif.  
 KFHJ, Santa Barbara, Calif.; Fallon Co.  
 KFBG, Pueblo, Colo.; Loewenthal Bro.  
 KFI, Los Angeles, Calif.; Earl C. Anthony, Inc.  
 KFJ, Gridley, Calif.; The Precision Shop.  
 KFV, Yakima, Wash.; Foster-Bradbury Radio Store.  
 KFZ, Spokane, Wash.; Deerr-Mitchell Elec. Co.  
 KGB, Tacoma, Washington, Tacoma Daily Ledger; H. F. Hinckley.  
 KGG, Portland, Ore.; Hallock & Watson Radio Service.  
 KGN, Portland, Ore.; Northwestern Radio Mfg. Co.  
 KGD, Alameda, Cal., 2500 miles; every Saturday 8 to 9:30 p. m. Musical program; Paul Franklin Johnson, Alameda Radio Lab.  
 KGU, Honolulu, Hawaii, Waikiki Beach, Marion A. Mulrone; Honolulu Advertiser.  
 KGW, Portland, Ore.; Oregonian Pub. Co., also 400.  
 KGV, Lacey, Wash.; St. Martin's College, (Rev. S. Ruth).  
 KHD, Colorado Springs, Colo.; Class B, 485, C. F. Aldrich; Marble & Granite Co.  
 KHJ, Los Angeles, Cal.; 400 meters, daily, 12:30 to 1:15 p. m.; from 7 to 7:30 p. m. and 8 to 9:30 p. m.; Los Angeles Times Mirror Co.  
 KHQ, Seattle, Wash.; Louis Wasmer.  
 KJJ, Sunnyvale, Calif.; The Radio Shop.  
 KJQ, Stockton, Calif.; C. O. Gould.  
 KJS, Los Angeles, Calif.; Bible Inst. of Los Angeles.  
 KLB, Pasadena, Calif.; J. J. Dunn & Co.

KLM, Del Monte, Calif.; Noggle Elec. Works.  
 KLP, Los Altos, Calif.; Collin B. Kennedy Co.  
 KFDH, Tucson, Ariz.; Univ. of Arizona.  
 KLS, Oakland, Calif.; Warner Bros.  
 KLV, San Francisco, Calif.; Tribune Pub. Co.  
 KLX, Denver, Colo.; Class B, 485, Reynolds Radio Co.  
 KMAZ, Macon, Ga.; Mercer University.  
 KMC, Reedley, Calif.; Lindsay-Wetherill Co.  
 KMJ, Fresno, Calif. Max. 2576 Miles; Musical program, San Joaquin Light & Tower Corp.  
 KMD, Tacoma, Wash. Love Electric Co.; Tacoma Times.  
 KNI, Eureka, Calif.; T. W. Smith.  
 KNJ, Roswell, New Mexico, 360, 485, 1000 miles; Every evening at 8; news, weather reports, stock market, concerts and sermons; Roswell Public Service Co.  
 KNN, Los Angeles, Calif.; Bullocks.  
 KNT, Aberdeen, Wash.; North Coast Products Co.  
 KNM, Los Angeles, Calif.; Western Radio Electric Co.  
 KNX, Los Angeles, Calif.; Elec. Lighting Supply Co.  
 KDA, Denver, Colo.; Y. M. C. A.  
 KDB, State College, N. Mex. 485 also; time signals and weather reports 12 noon and 10: p. m. mountain time; music and lectures Monday, Wednesday and Friday, 7:30 to 8:30 p. m.; New Mexico College of Agriculture and Mechanical Arts.  
 KDE, Spokane, Wash.; Spokane Chronicle.  
 KDG, Los Angeles, Calif.; Western Radio Electric Co.  
 KDN, Los Angeles, Calif.; Holzwasser, Inc.  
 KDP, Detroit, Mich.; Detroit Police Dept.  
 KDQ, Modesto, Calif.; Modesto Evening News.  
 KPD, San Francisco, Calif.; Hale Bros.  
 KQI, Berkeley, Calif.; Univ. of California.  
 KQJ, Hood River, Ore.; Blue Diamond Elec. Co.; Hood River News.  
 KQK, Pittsburgh, Pa.; Doubleday-Hill Elec. Co.  
 KQW, San Jose, Calif.; Chas. D. Herrold.  
 KQY, Portland, Ore.; 1,000 miles, Monday, Tuesday, Saturday, 9 to 10 p. m.; Wednesday, Thursday, Friday, 6 to 7 p. m.; Stubbs Electric Co.  
 KRE, Berkeley, Calif.; Maxwell Electric Co.  
 DSC, San Jose, Calif., O. A. Hale & Co.  
 KSD, St. Louis, Mo.; 1700 miles; 485 meters; grain, livestock, cotton, New York stocks, poultry and butter market, metal market, official weather and news at 9:30, 10:40, 11:40, 12:40, 1:40, 2:40 and 4 p. m.; 8 p. m. 400 meters, musical and other features; Pulitzer Publishing Co., St. Louis Post Dispatch.  
 KSL, San Francisco, Calif., The Emporium.  
 KSS, Long Beach, Calif.; Preat & Dean Radio Research Lab.  
 KSU, Wenatchee, Wash., 360 and 485.  
 KST, Seattle, Wash., First Presbyterian Church.  
 KUD, San Francisco, Calif.; Examiner Printing Co., San Fran. Examiner.  
 KUS, Los Angeles, Cal. 500 miles; setting up exercises daily, 7 to 7:30 a. m. and 12:00 noon to 12:30 p. m.; concert, 65 voices, 6 to 6:15 p. m. Wednesdays and Fridays; City Dya Works.  
 KUY, Del Monte, Calif., Coast Radio Co.  
 KWG, Stockton, Cal. Daily Market reports, music and news 4 to 5 p. m.; Music, 2 to 3 p. m., Sunday; Tuesdays and Fridays, music, 8 to 9 p. m. Portable Wireless Telephone Co.  
 KWH, Los Angeles, Calif., 485 also Los Angeles Examiner.  
 KXD, Modesto, Calif., Herald Publishing Co.  
 KXS, Los Angeles, Calif., Braun Corp.  
 KYI, Bakersfield, Calif., Alfred Harrell.  
 KYJ, Los Angeles, Calif., Leo J. Meyberg Co.  
 KYQ, Honolulu, T. H., The Electric Shop.  
 KYW, Chicago, Ill., Westinghouse Elec. & Mfg. Co.  
 KZC, Seattle, Wash., Public Market & Dept. Store Co.  
 KZM, Oakland, Calif., Western Radio Inst.; Preston D. Allen.  
 KZN, Salt Lake City, Utah, The Deseret News.  
 KZV, Wenatchee, Wash., Wenatchee Battery & Motor Co.  
 NDF, Anacostia, D. C., 412 only, U. S. Navy Dept.  
 FWY, Havana, Cuba, Cuban Radio Co.  
 WAI, Dayton, Ohio, McCook Field, U. S. Army.  
 WAAB, New Orleans, La., Yaldemar Jensen.  
 WAAC, New Orleans, La., Tulane Univ.  
 WAAD, Cincinnati, Ohio, Ohio Mechanics Inst.  
 WAAF, Chicago, Ill., Chicago Daily Drivers Journal.  
 WAAG, St. Louis, Mo., St. Louis Chamber of Commerce.  
 WAAB, St. Paul, Minn.; Commonwealth Electric Co.  
 WAAJ, Boston, Mass., Eastern Radio Inst.  
 WAAK, Milwaukee, Wis., Gimbel Bros.  
 WAAL, Minneapolis, Minn., Minnesota Tribune Co. & Anderson-Heamish Co.  
 WAAM, Newark, N. J., 200 miles; musical and code, every week day 11 to 11:55 a. m., 3 to 4 p. m.; Wednesday evenings 8 to 9; I. H. Nelson Company.  
 WAAP, Wichita, Kans., United Elec. Co.; Otto W. Taylor.  
 WAAQ, Greenwich, Conn., New England Motor Sales Co.  
 WAAS, Decatur, Ga., Georgia Radio Co.  
 WAAT, Jersey City, N. J., Jersey Review.  
 WAAW, Omaha, Neb., Omaha Grain Exchange.  
 WAAY, Youngstown, Ohio, Yohrling-Rayner Music Co.  
 WBAZ, Omaha, Kans.; Daylite 100 miles; nix 500-1000 miles; each Tuesday and Thursday from 7 to 8 p. m. Acknowledg all communications at 7:15 p. m. The Hollister Miller Motor Co.  
 WAH, El Dorado, Kans., Midland Refining Co.  
 WAJT, Marshall, Mo., Kelly-Vawter Jewelry Co.  
 WAJU, Yankton, S. D., Yankton College.  
 WBAA, W. Lafayette, Ind., Purdue University.  
 WBAD, Minneapolis, Minn., Sterling Elec. Co. & Journal Printing Co.  
 WBAE, Peoria, Ill., Bradley Polytechnic Inst.  
 WBAF, Moorestown, N. J., Fred M. Middleton.  
 WBAG, Bridgeport, Pa., Diamond State Fibre Co.  
 WBAH, Minneapolis, Minn., The Dayton Co.  
 WBAM, New Orleans, La., I. B. Renssion.  
 WBAN, Paterson, N. J., Wireless Phone Corp.  
 WBAP, Decatur, Ill., James Millikin Univ.  
 WBAP, Fort Worth, Tex. 400-485; 4000 miles; Markets and News; Feature concert Monday to Friday inclusive; 9:30 p. m. Central Time; Quiet nights Saturday and Sunday. The Star-Telegram.  
 WBAQ, South Bend, Ind., Myron L. Harmon.  
 WBAU, Hamilton, Ohio, Republican Publishing Co.  
 WBAV, Columbus, Ohio, 485, also Erner & Hopkins Co.  
 WBAW, Marietta, Ohio, Marietta College.  
 WBAX, Wilkes-Barre, Pa., John H. Stenger, Jr.  
 WBL, Anthony, Kans., T. & H. Radio Co.

(Continued on next page.)

# Corrected List of U. S. Stations Alphabetically by Call Signals

- WBS, Newark, N. J., D. W. May, Inc.  
 WBT, Charlotte, N. C. 1200 miles; 11: a m weather report 485; 4:30 p m mechanical music; 8: p m Market Report; 8:30 Tuesday and Friday regular concert; 7:30 p m Sunday, Church Southern Radio Corp.  
 WBU, Chicago, Ill., City of Chicago.  
 WBL, Springfield, Mass., Westinghouse Elec. & Mfr. Co.  
 WCB, Newburgh, N. Y., Newburgh Daily News; Newburgh News Printing & Pub. Co.  
 WCAC, Fort Smith, Ark., John Fink Jewelry Co.  
 WCAD, Canton, N. Y., St. Lawrence University.  
 WCAE, Pittsburgh, Pa., 400 also; Kaufmann & Baer Co.  
 WCAE, Pittsburgh, Pa. 400 meter; 12:30 news and reports; 3:30 weather reports; 4:15 Closing Market reports; 7:30 Late news and lecture; 8:30 musical programs; Kaufmann Baer Co.  
 WCAE, New Orleans, La., Daily States Pub. Co.  
 WCAH, Columbus, O. Daily program 11:30 to 12:30; Every Tuesday evening at 7, musical program; C. A. Entekin Electric Co.  
 WCAI, San Antonio, Texas, Southern Equipment Co.  
 WCAJ, Univ. Place, Neb., Nebraska Wesleyan University.  
 WCAK, Houston, Texas, Alfred P. Daniel.  
 WCAK, Northfield, Minn., St. Olaf College.  
 WCAN, Villanova, Pa., Villanova College.  
 WCAO, Baltimore, Md., Sanders & Stayman Co.  
 WCAP, Kalamazoo, Mich., Kalamazoo College.  
 WCAR, San Antonio, Texas, Alamo Radio Elec. Co.  
 WCAS, Minneapolis, Minn., Wm. H. Dunwoody Industrial Inst.  
 WCAT, Rapid City, S. Dak., 485 also South Dakota School of Mines.  
 WCAU, Philadelphia, Pa. 485 also; 1000 miles; Daily 10:30 a m; 2:30 p m; 6:30 p m; regular concert 10 to 12 noon; Tuesdays, Fridays, Saturdays; Durham & Co., Inc.  
 WCAV, Little Rock, Ark., J. C. Dice Elec. Co.  
 WCAW, Omaha, Neb., Woodmen of the World.  
 WCAX, Burlington, Vermont, University of Vermont.  
 WCE, Milwaukee, Wis., Kesselman O'Driscoll Co.  
 WCE, Minneapolis, Minn., Findley Elec. Co.  
 WCM, St. Louis, Mo., Stix Baer & Fuller.  
 WCM, Austin, Texas, Univ. of Texas.  
 WCN, Worcester, Mass., 485 also Clark University.  
 WCX, Detroit, Mich., Detroit Free Press.  
 WDAC, Springfield, Ill., Ill Watch Co.  
 WDAE, Tampa, Fla., 485 also Tampa Daily News.  
 WDAF, Kansas City, Mo., 400 and 485, also Kansas City Star.  
 WDAF, Amarillo, Texas, K. Laurens & Main.  
 WDAH, El Paso, Texas, Mine & Smelter Supply Co.  
 WDAI, Syracuse, N. Y., 485 also Hughes Electrical Corp.  
 WDAJ, College Park, Ga., Atlanta & West Point R. R. Co.  
 WDAK, Hartford, Conn., Hartford Courant.  
 WDAK, Jacksonville, Fla., 485 also Florida Times Union.  
 WDAO, Dallas, Texas, Automobile Elec. Co.  
 WDAF, Chicago, Ill., markets, 485; concerts 360; Daily on all business days; 9:30 a. m. receipts and shipments; estimated car lots; local weather report; opening futures market in wheat, corn, oats, rye, barley, pork, lard and ribs. 10 a. m. Future quotations, live stock receipts and prices; 10:30 a. m. futures quotations; 11 and 11:30 a. m. same; 12 noon, futures and cash grain prices; 12:30 and 1 p. m. futures quotations; 1:20 p. m. closing futures quotations and high and low for day. Cash grain prices. Gross bids for cash grain to arrive. 6 p. m. closing quotations; news items. On Saturdays closing prices at 12:05 p. m. instead of 1:20 p. m. Visible supply changes sent when posted. Regular concert schedule 10 p. m. Tuesdays, Thursdays and Saturdays. Sunday evenings 9 p. m. and 10 p. m. Chicago Board of Trade official station.  
 WDAG, Brownsville, Pa., Hartman-Riker Elec. & Mach. Co.  
 WDAR, Philadelphia, Pa., Lit Bros.  
 WDAS, Worcester, Mass., Samuel A. Waite.  
 WDAU, New Bedford, Mass., Slouss & Kilburn.  
 WDAX, Centerville, Iowa, First Nat'l Bank.  
 WDAY, Fargo, N. D., Kenneth M. Hance.  
 WDM, Washington, D. C., Church of the Covenant.  
 WDT, New York, N. Y., Ship Owners Radio Service.  
 WDV, Omaha, Neb., John O. Yelzer, Jr.  
 WDW, Tuscola, Ill., James L. Bush.  
 WDEA, Flint, Mich., Fallah & Lathrop.  
 WEAB, Fort Dodge, Iowa, Standard Radio Equip. Co.  
 WEAC, Terre Haute, Ind., Baines Elec. Service Co.  
 WEAD, Atwood, Kans., Northwest Kansas Radio Supply Co.  
 WEAE, Blackburg, Va., Virginia Polytechnic Inst.  
 WEAF, New York City, N. Y., Western Electric Co.  
 WEAG, Edgewood, R. I., Nichols-Hemelne-Bassett Lab.  
 WEAH, Wichita, Kans., Wichita Board of Trade and Lander Radio Co.  
 WEAI, Ithaca, N. Y., Cornell University.  
 WEAJ, Vermillion, S. Dak., University of South Dakota.  
 WEAK, St. Joseph, Mo., Julius B. Abercrombie.  
 WEAM, North Plainfield, N. J., Borough of N. Plainfield.  
 WEAN, Providence, R. I., The Shepard Co.  
 WEAO, Columbus, Ohio, Ohio State University.  
 WEAP, Mobile, Ala., 485 also Mobile Radio Co.  
 WEAQ, Berlin, N. H., Y. M. C. A.  
 WEAR, Baltimore, Md., Balt. American & News Pub. Co.  
 WEAS, Washington, D. C., The Hecht Co.  
 WEAT, Tampa, Fla., John J. Fogarty.  
 WEAU, Sioux City, Iowa, Davidson Bros. Co.  
 WEAV, Rushville, Neb., Sheridan Elec. Service Co.  
 WEW, Anderson, Ind., Arrow Radio Lab.  
 WEAX, Little Rock, Ark., T. J. M. Daly.  
 WEAY, Houston, Texas, Will Horwitz, Jr.  
 WEAZ, Waterloo, Iowa, Donald Redmond.  
 WEB, St. Louis, Mo., The Benwood Co., Inc.  
 WEH, Tulsa, Okla., Midland Refining Co.  
 WEV, Houston, Texas, 485 also Hurlburt-Still Elec. Co.  
 WEW, St. Louis, Mo., 485 also St. Louis Univ.  
 WEW, St. Louis, Mo., 360 and 485; Market and weather reports at 9: a m. 10: a m. 2: p m; no other regular program; St. Louis University.  
 WEY, Wichita, Kansas, 485 also Cosradio Co.  
 WFAA, Dallas, Texas, 400 and 485 also A. H. Belo & Co.  
 WFAW, Miami, Fla., 1500 miles; 7:30 to 9 p. m. concerts including Arthur Pryor's Band evenings and W. J. Bryan Sunday School, Sunday a m; Miami Daily Metropolis & Electrical Equipment Co.  
 WEAB, Syracuse, N. Y., C. F. Woese.  
 WFAC, Superior, Wis., Superior Radio Co.  
 WFAD, Salina, Kans., Watson-Weldon Motor Supply Co.  
 WFAP, Poughkeepsie, N. Y., H. C. Spradley Radio Co.  
 WFAG, Waterford, N. Y., Radio Engineering Lab.  
 WFAH, Port Arthur, Texas, Elec. Supply Co.  
 WFAJ, Asheville, N. C., Hi-Grade Wireless Instrument Co.  
 WFAK, Brentwood, Mo., Domestic Electric Co.  
 WFAH, St. Cloud, Minn., 485 also Granite City Elec. Co. and Times Pub. Co.  
 WFAH, Hutchinson, Minn., 485 also Hutchinson Electric Service Co.  
 WFAO, Cameron, Mo., Cameron Radio Co. and Mo. Wesleyan College.  
 WFAS, Fort Wayne, Ind., United Radio Corp.  
 WFAT, Sioux Falls, S. Dak., 485; also Argus-Leader.  
 WFAU, Boston, Mass., Edwin C. Lewis.  
 WFAV, Lincoln, Neb., 485 also Univ. of Nebr. Dept. of Elec. Engineering.  
 WFAZ, Independence, Kans., Daniels Radio Supply Co.  
 WFAZ, Charleston, E. Carolina, S. C. Radio Shop.  
 WFI, Philadelphia, Penn., 400 and 485, also Strawbridge & Clothier.  
 WGB, Houston, Texas, ORV Radio Co.  
 WGC, Brooklyn, N. Y., Grubman Radio Stores Co.  
 WGD, Esenada, Porto Rico, Spanish-American School of Radio-Telescopy.  
 WGF, Des Moines, Iowa 300 miles; Musical and entertainment Tuesday and Friday 7:30 p m; Church Services Sunday at 5 p m or 7:45 p m as announced; Special programs as announced Register and Tribune.  
 WGAH, New Haven, Conn., New Haven Elec. Co.  
 WGAJ, Shenandoah, Iowa, W. H. Gass.  
 WGAK, Macon, Ga., Mason Elec. Co.  
 WGAL, Lancaster, Pa., Lancaster Elec. Supply & Construction Co.  
 WGAN, Orangeburg, S. C., Orangeburg Radio Equip. Co.  
 WGAN, Pensacola, Fla., Cecil E. Lloyd.  
 WGB, Shreveport, La., Glenwood Radio Corp.  
 WGB, Fort Smith, Ark., Southwest American.  
 WGAT, Lincoln, Neb., Am. Legion, Dept. of Nebr.  
 WGAU, Wooster, Ohio, Marcus G. Limh.  
 WGAU, Savannah, Ga., B-H Radio Co.  
 WGAU, Altoona, Pa., Ernest C. Albright.  
 WGAX, Washington Court House, Ohio, Ohio Radio Elec. Co.  
 WGAZ, Madison, Wis., North Western Radio Co.  
 WGAZ, South Bend, Ind., South Bend Tribune.  
 WGI, Medford Hillside, Mass., 485, also Am. Radio & Research Corp.  
 WGL, Philadelphia, Pa., Thos. F. J. Howlett.  
 WGM, Atlanta, Ga., 400 only, Atlanta Constitution.  
 WGR, Buffalo, N. Y., 485 also Federal Tel. & Teleg. Co.  
 WGN, New Orleans, La., Interstate Elec. Co. 485 also.  
 WGT, Schenectady, N. Y., 400 and 485 also General Elec. Co.  
 WHA, Madison, Wis., 485 also Univ. of Wis.  
 WHAA, Iowa City, Ia.; 500 miles; 8:30 p m, Monday, instruction; Tuesday, concert; Wednesday, popular lecture; Friday, University News; public lectures and concerts irregularly; State University of Iowa.  
 WHAB, Galveston, Texas, 300, 485, 600 also Clark W. Thompson (Fellman's Dry Goods Co.)  
 WHAC, Waterloo, Iowa, Cole Bros. Elec. Co.  
 WHAD, Milwaukee, Wis., 485 also; Marquette Univ.  
 WHAE, Sioux City, Iowa, Automobile Elec. Service Co.  
 WHAF, Pittsburgh, Pa., Radio Elec. Co.  
 WHAG, Cincinnati, Ohio, Univ. of Cincinnati.  
 WHAH, Joplin, Mo. 300 miles; Tuesday and Thursday nights 8 to 10; Hafer Supply Co.  
 WHAI, Davenport, Iowa, Radio Equip. & Mfr. Co.  
 WHAJ, Bluefield, W. Va., Bluefield Daily Telegraph and E. K. Kitts.  
 WHAK, Clarisburg, W. Va., Roberts Hdwe. Co.  
 WHAL, Lansing, Mich., Lansing Capitol News.  
 WHAM, Rochester, N. Y. 485 also; Daily—Weather report 2:40 p m; Organ 2:45, 5:00, 6:45; Orchestra 3:00, 7:00; Bed-time stories, Sport results, Business reports and market reports, the latter on 485 meters, 7:15 p m; Sunday—Radio Chapel Service, 9:15 p m; University of Rochester.  
 WHAO, Savannah, Ga., Frederick A. Hill; every evening 8 to 9; Saturday nights, 12:30 to 1:30 a. m.  
 WHAP, Decatur, Ill., Dewey L. Otta.  
 WHAQ, Washington, D. C., Semmes Motor Co.  
 WHAR, Atlantic City, N. J., Paramount Radio & Elec. Co.  
 WHAS, Louisville, Ky., Courier Journal and Louisville Times Co.  
 WHAV, Wilmington, Del., Wilmington Elec. Spec. Co.  
 WHAW, Tampa, Fla. 100 miles; 12 to 1, 4 to 5 p m, music; Pierce Electric Co.  
 WHX, Des Moines, Iowa; 300 miles; 5:45 p m to 6:15 p m Daily; 8:00 p m to 10 p m Wednesday evenings; Central Standard time; Iowa Radio Corp.  
 WHAY, Huntington, Ind., Huntington Press.  
 WHAZ, Troy, N. Y., 400 only, Rensselaer Polytechnic Inst.  
 WHB, Kansas City, Mo., 400 and 485 also Sweeney Auto & Tractor School.  
 WHC, Morgantown, W. Va., West Virginia University.  
 WHK, Cleveland, Ohio, Warren R. Cox.  
 WHN, Ridgewood, N. Y., Times Printing & Pub. Co.  
 WHU, Toledo, Ohio, Wm. B. Duck Co.  
 WIAB, Rockford, Ill., Joslyn Automobile Co.  
 WIAC, Galveston, Texas, 485 also Galveston Tribune.  
 WIAD, Ocean City, N. J., Ocean City Yacht Club.  
 WIAP, Vinton, Iowa, Mrs. Robt. E. Zimmerman.  
 WIAP, New Orleans, La., Gustave A. DeGortin.  
 WIAG, Norfolk, Neb.; 485 also; 200 miles News and Markets 12:15, 3:30 and 5:30 p m. The Huse Publishing Co. The Norfolk Daily News.  
 WIAH, Newton, Iowa, Continental Radio & Mfg. Co.  
 WIAI, Springfield, Mo., Heer Stores Co.  
 WIAJ, Neenah, Wis., Fox River Valley Radio Supply Co.  
 WIAM, Omaha, Neb.; 485, 7:45 a m Livestock receipts; 9:10 a m Livestock receipts and organ recital; 9:10 a m rain and temperature report and weather forecast for Nebraska and Iowa, Livestock market; 12 m cattle, hog and sheep market; 1:50 p m rainfall and temperature report and weather forecast for Nebraska and Iowa; market detail; 3:50 p m complete market reports and estimated receipts for next day; Daily Journal-Stockman.  
 WIAP, Milwaukee, Wis., School of Engineering.  
 WIAP, Springfield, Mass., Radio Development Corp.  
 WIAP, Dayton, Ind., Chronicle Pub. Co.  
 WIAR, Paducah, Ky., Musical 3:30 to 4 p. m. and 7 to 8 p. m. except Sundays. Paducah Evening Sun; Albert Bennett, operator.  
 WIAS, Burlington, Iowa, Hawk-Eye Home Elec. Co.  
 WIAT, Tarkio, Mo., Leon T. Noel.  
 WIAP, La Mars, Iowa, Am. Trust & Savings Bank.  
 WIAP, Birmingham, N. Y., N. Y. Radio Lab.  
 WIAP, Saginaw, Mich., Saginaw Radio & Elec. Co.  
 WIAX, Lincoln, Neb., Capitol Radio Co.  
 WIAY, Washington, D. C., Woodrow & Lathrop.  
 WIAZ, Miami, Fla., Elec. Supply Sales Co.  
 WIK, McKeesport, Pa. K & L Elec. Shop.  
 WIL, Washington, D. C., Continental Elec. Supply Co.  
 WIP, Philadelphia, Pa., Gimbel Bros. Radio Lab.  
 WIZ, Cincinnati, Ohio, 485 also Cino Radio Mfg. Co.  
 WJAB, Lincoln, Neb., American Radio Co.  
 WJAD, Waco, Texas, 485 also Jackson's Radio Engrng. Lab.  
 WJAE, San Antonio, Texas, Texas Radio Syndicate.  
 WJAF, Muncie, Ind.; 1800 miles; 7:30 to 8 Monday, Wednesday, Friday evening, music; 6:30 to 7 p m Saturday, music; 3:30 to 4 every afternoon, News; 10:30 to 12 M Sundays, Church service. Smith Electric-Music Press.  
 WJAG, Dayton, Ohio 200 miles; Sunday 8:40, 9:15 Religious; Wednesday 9:15, 9:45 Entertainment; Friday 9:15 to 9:45 Entertainment. Y. M. C. A.  
 WJAK, Stockdale, Ohio, 485 also White Radio Lab.  
 WJAM, Cedar Rapids, Iowa, Evening Gazette.  
 WJAN, Peoria, Ill. Daily except Sunday; 9:15 a. m. official weather (185); 11:20 a. m. weather and markets (360) 1:30 p. m. market close (360). Tuesday, Thursday and Saturdays; concerts at 9:15 p. m. Peoria Star.  
 WJAP, Duluth, Minn. 1500 miles; Sunday 11 a. m. 12:50 p m Church Service and organ recital; Tuesday, Wednesday, Thursday, Friday, 8:40, 9:15 Religious; Monday 8: p m to 9 p m, musical; Thursday 8 p m to 9 p m, musical; Kelley Duluth Co.  
 WJAG, Topeka, Kans., Carper Publications.  
 WJAR, Providence, R. I., The Outlet Co., J. Samuels & Bros.  
 WJAS, Pittsburgh, Pa., Pittsburgh Radio Supply House.  
 WJAT, Marshall, Mo., Kelley-Yawter Jewelry Co.  
 WJAX, Cleveland, Ohio, 485 also Union Trust Co.  
 WJAZ, Chicago, Ill., Chicago Radio Lab.  
 WJD, Dayton, Ohio 100 miles; must be Denison Conservatory, educational lectures and discussion; Denison University.  
 WJH, Washington, D. C., White & Boyer Co.  
 WJK, Toledo, Ohio, Service Radio Equipment Co.  
 WJX, New York, N. Y., De Forest Radio Telephone & Teleg. Co.  
 WJZ, Newark, N. J., 485 also Westinghouse Elec. & Mfg. Co.  
 WKAA, Cedar Rapids, Iowa, 485 also H. F. Parr.  
 WKAC, Lincoln, Neb., Star Pub. Co.  
 WKAF, Wichita Falls, Texas, W. S. Radio Supply Co.  
 WKAG, Louisville, Ky., Edwin T. Bruce, M. D.  
 WKAK, West Palm Beach, Fla., Planet Radio Co.  
 WKAK, Okemah, Okla., Okfuskee County News.  
 WKAL, Orange, Texas, Gray & Gray.  
 WKAN, Montgomery, Ala., Alabama Radio Mfg. Co.  
 WKAP, Cranston, R. I., Dutec W. Flint.  
 WKAA, San Juan, Porto Rico, Radio Corp. of Porto Rico.  
 WKAR, East Lansing, Mich., Mich. Agr. College.  
 WKAS, Springfield, Mo., L. E. Lines Music Co.  
 WKAV, Laconia, N. H., Laconia Radio Club.

(Continued on next page.)



# Corrected List of U.S. Stations Alphabetically by Call Signals

WKAW, Beloit, Wis., Turner Cycle Co.  
 WKAX, Bridgeport, Conn., Wm. A. MacFarlane.  
 WKAY, Gainesville, Ga., Brenau College.  
 WKC, Baltimore, Md., Jos. M. Zamolski Co.  
 WKN, Memphis, Tenn., Riechman-Crosby Co.  
 WKY, Oklahoma City, Okla., 485 also Oklahoma Radio Shop.  
 WLZ, Fairfield, Ohio, U. S. Army.  
 WLAC, Raleigh, N. C., N. C. State College.  
 WLAJ, Lincoln, Nebr., Johnson Radio Co.  
 WLAG, Minneapolis, Minn., Cutting & Walsh Radio Corp.  
 WLAH, Syracuse, N. Y., Samuel Woodworth.  
 WLAJ, Waco, Texas, 485 also Waco Elec. Supply Co.  
 WLAJ, Bellevue Falls, Va., Vermont Farm Machine Co.  
 WLAL, Tulsa, Okla., Tulsa Radio Co.  
 WLAM, Springfield, Ohio, Morrow Radio Co.  
 WLAN, Houlton, Me., Putnam Hdwe. Co.  
 WLAP, Louisville, Ky., W. V. Jordan.  
 WLAQ, Kalamazoo, Mich., A. E. Schilling.  
 WLAJ, Marshalltown, Iowa, Melkel Music Co.  
 WLAS, Hutchinson, Kans., Hutchinson Grain Radio Co.  
 WLAT, Burlington, Iowa, Radio Specialty Co.  
 WLAV, Pensacola, Fla.; daily musical program, 8 to 9 p m; The Electric Shop.  
 WLAW, New York, N. Y., New York Police Dept.  
 WLAX, Greencastle, Ind., Greencastle Community Broadcasting Station.  
 WLAY, Fairbanks, Alaska, Northern Commercial Co.  
 WLAZ, Warren, Ohio, Eulton & Jones Elec. Co.  
 WLB, Minneapolis, Minn., Univ. of Minn.  
 WLK, Indianapolis, Ind., 485 also Hamilton Mfg. Co.  
 WLW, Cincinnati, Ohio, 485 also Crosley Mfg. Co.  
 WMA, Anderson, Ind., Arrow Radio Lab.  
 WMAJ, Oklahoma City, Okla., Radio Supply Co.  
 WMAK, Cozenovia, N. Y., 750 miles; music 11 p m; Cleve B. Meredith.  
 WMAJ, Rockport, Mo., Atchinson County Mail.  
 WMAE, Dartmouth, Mass., Round Hills Radio Corp.  
 WMAJ, Liberal, Kans., Tucker Elec. Co.  
 WMAH, Lincoln, Nebr., General Supply Co.  
 WMAJ, Kansas City, Mo., 485 also Drivers Telegram.  
 WMAK, Lockport, N. Y., Norton Labs.  
 WMAJ, Trenton, N. J., 100 miles; 7:30 to 9 p m, Mondays and Thursdays, musical programs, lectures etc; Trenton Hardware Co.  
 WMAJ, Beaumont, Texas, Beaumont Radio Equip. Co.  
 WMAJ, Columbus, Ohio, First Baptist Church.  
 WMAJ, Easton, Pa., Utility Battery Service.  
 WMAJ, Fair Store Building, Chicago; 4:35 to 5 p m, daily; 7 to 7:30 p m, Monday, Wednesday, Friday and Saturday; 7 to 8 p m, Tuesday and Thursday; 9:15 to 10 p m daily; Chicago Daily News and Fair Department Store.  
 WMAJ, Waterloo, Iowa, Waterloo Elec. Supply Co.  
 WMAJ, Duluth, Minn., Paramount Radio Corp.  
 WMAJ, Auburn, Ala., Polytechnic Inst.  
 WMAJ, Wahpeton, N. D., Wahpeton Elec. Co.  
 WMAJ, Ann Arbor, Mich., K. & K. Radio Supply Co.  
 WMAJ, St. Louis, Mo., 400 miles; Religious services Sunday, 11 a m and 8 p m; Tuesday at 7 p m; Kingshighway Presbyterian Church.  
 WMAJ, Macon, Ga., Mercer University.  
 WMB, Auburn, Maine, Auburn Elec. Co.  
 WMH, Cincinnati, Ohio, 485 also Precision Equipment Co.  
 WMU, Washington, D. C., Doubleday-Hill Electric Co.  
 WMAJ, Bowling Green, Ky., Park City Daily News.  
 WMAJ, Boston, Mass.; Monday 4 to 5 p. m. (silent at night) Tuesday 4 to 5 p. m. and 7 to 8:30 p. m. Wednesday 4 to 5 p. m. 9:30 to 11 p. m. Thursday 4 to 5 and 7 to 8:30 p. m. Friday 4 to 5 and 8 to 9:30 p. m. Saturday 4 to 5 and 9:30 to 11 p. m. The Shepard Stores; J. J. Parlane, announcer; Samuel Curtis, operator.  
 WMAJ, Norman, Okla., Okla. Radio Engineering Co.  
 WMAJ, Enid, Okla., Enid Radio Dist. Co.  
 WMAJ, Manhattan, Kans., Manhattan Radio Supply Co.  
 WMAJ, Omaha, Nebr., R. J. Rockwell.  
 WMAJ, Syracuse, N. Y., Syracuse Radio Telephone Co.  
 WMAJ, Springfield, Ohio, Wittenberg College.  
 WMAJ, Charleston, S. C., Charleston Radio Elec. Co.  
 WMAJ, Austin, Texas, Radio Corp.  
 WMAJ, Philadelphia, Pa., 1000 miles; Talks, Radio information, music, Chapel service, Wednesday 7:30 to 8 p. m. Saturday 7:30 p m; Sunday 2:30 and 4:30; Every day 12:15, 3 p m, Lennig Bros. Co.  
 WMAJ, Knoxville, Tenn., People's Tel. and Tel. Co.  
 WMAJ, Baltimore, Md., Shipowners' Radio Service.  
 WMAJ, Yankton, S. D., Dakota Radio Apparatus Co.  
 WMAJ, Fortress Monroe, Va., Henry Kunzman.  
 WMAJ, Albany, N. Y., Shotton Radio Mfg. Co., Inc.  
 WMAJ, Jersey City, N. J., Wireless Telephone Co. of Hudson Co., N. J.  
 WMAJ, Omaha, Nebr., 100 miles; Woodmen of the World.  
 WMAJ, Ardmore, Okla., Dr. Walter Hardy.  
 WMAJ, Lima, Ohio, Maus Radio Co.  
 WMAJ, Fremont, Nebr., Medland College.  
 WMAJ, Tyler, Texas, Tyler Commercial College.  
 WMAJ, Charleston, S. C., Palmetto Radio Corp.  
 WMAJ, San Antonio, Tex., 485 also; daily except Sunday 10:30, 12:15, 3, 6 p m, News, market, weather reports; Wednesday, Concert 7:30 to 8:30 p m; Sunday evening concert 9:30 to 10:30 p m; Southern Equipment Co. and The Evening News and The Express.  
 WMAJ, Parsons, Kans., Erving's Electrical Co.  
 WMAJ, Frankfort, Ky., Collins Hardware Co.  
 WMAJ, Webster Groves, Mo., Wm. E. Woods.  
 WMAJ, Lawrenceburg, Tenn., James D. Vaughan.  
 WMAJ, Kenosha, Wis., Henry P. Lundskow.  
 WMAJ, Middleton, Conn., Bailey's Radio Shop.  
 WMAJ, Wilmington, Del., Boyd Martell Hamp.  
 WMAJ, Evansville, Ind., Sowder Bolting Piano Co.  
 WMAJ, Erie, Pa., Pa. Nat'l Guard.  
 WMAJ, Trenton, N. J., Franklin J. Wolf.  
 WMAJ, Birmingham, Ala., John W. Wilder.  
 WMAJ, Portsmouth, Va., Portsmouth Radio Ass'n.  
 WMAJ, Omaha, Neb., 100 miles, Woodmen of the World.  
 WMAJ, Stanford, Texas, Penick Hughes Co.  
 WMAJ, Davenport, Ia., 485 meters; time signals, 10:55 a m; weather 11 a m; 360 meters, 11:05 opening market quotations, astrograms; 12:00 noon, chimes concert; 2:00 p m, closing stocks and markets; 3:30 p m, educational talk; 5:45 p m, chimes concert; 6:35, sandman's slait; 7:30 musical program; 8 p m, lecture; Sundays, religious and musical and religious features, 9 a m to 10 p m; Palmer's School of Chiropractic.

WMAJ, Indianapolis, Ind., Hatfield Elec. Co.  
 WMAJ, Ames, Ia., 485 also Iowa State College.  
 WMAJ, Pine Bluff, Ark., concerts Tuesday and Friday evenings beginning at 9; Sundays, song service and sermons from churches at 11 a. m. and 7:30 p. m., Arkansas Light & Power Co.  
 WMAJ, Philadelphia, Pa., 400 and 485 also, John Wanamaker.  
 WMAJ, Kansas City, Mo., 485 also Western Radio Co.  
 WMAJ, Newark, N. J., 400 only, L. Bamberger & Co.  
 WMAJ, Jefferson City, Mo., 485 also; first fifteen minutes of every hour from 8: a m to 2: p m; 5 p m, markets and music, 360 meters; Monday, Wednesday, Friday nights, 8 to 9:30 concerts; no Sunday program; Missouri State Marketing Bureau.  
 WMAJ, Omaha, Nebr., R. B. Howell.  
 WMAJ, Omaha, Nebr., Metropolitan Utilities.  
 WMAJ, Richmond, Ind., 485 also Palladium Printing Co.  
 WMAJ, Fort Worth, Texas, 485 also Fort Worth Record.  
 WMAJ, Waukesha, Wis., Wisconsin Dept. of Markets.  
 WMAJ, Wahoo, Neb., Anderson & Webster Elec. Co.  
 WMAJ, State College, Pa.  
 WMAJ, Okmulgee, Okla., Donaldson Radio Co.  
 WMAJ, Chicago, Ill., Wieboldt & Co.  
 WMAJ, Council Bluffs, Iowa, Peterson's Radio Co.  
 WMAJ, Independence, Mo., Central Radio Co.  
 WMAJ, Waukesha, Wis., Wisconsin Dept. of Markets.  
 WMAJ, New Haven, Conn., Deolittle Radio Corp.  
 WMAJ, Fargo, N. D., North Dakota Agricultural College.  
 WMAJ, Columbus, Ohio, Superior Radio & Tel. Equip. Co.  
 WMAJ, Topeka, Kans., Awerbaeh & Guettel.  
 WMAJ, Winchester, Ky., Theo. D. Phillips.  
 WMAJ, Frostburg, Md., General Sales & Eng. Co.  
 WMAJ, Wilmington, Del., Radio Installation Co., Inc.  
 WMAJ, Beloit, Kans., R. A. Ward.  
 WMAJ, Amsterdam, N. Y., J. & M. Electric Co.  
 WMAJ, El Paso, Texas, St. Patrick's Cathedral.  
 WMAJ, Moorhead, Minn., Concordia College.  
 WMAJ, Laurium, Mich., Paul Tinetti & Sons.  
 WMAJ, Thomasville, Ga., S. W. Radio Co., J. R. Shumate, Jr.  
 WMAJ, Bangor, Me., Bangor Radio Laboratory.  
 WMAJ, Charleston, W. Va., Dr. John R. Koch.  
 WMAJ, Independence, Mo.  
 WMAJ, New Lebanon, Ohio 1500 miles; Program exclusive for the farmer; 12 to 12:15 p m News Flashes; 6 to 6:30 p m, News, Markets; 8 to 9:45 Monday and Wednesday; music and farm program. Nushawr Poultry Farm.  
 WMAJ, Clearfield, Pa., Elec. Supply Co.  
 WMAJ, Washington, D. C., Thos. J. Williams, Inc.  
 WMAJ, Memphis, Tenn., United Equip. Co.  
 WMAJ, Parkersburg, Pa., 1500 miles; 10:30 p m every evening. Horace A. Beale, Jr.  
 WMAJ, Springfield, Mo., Southwest Missouri State Teachers' College.  
 WMAJ, Amarillo, Texas, E. B. Gish.  
 WMAJ, Waterbury, Conn., Whitall Electric Co.  
 WMAJ, Springfield, Vt., Moore Radio News Station.  
 WMAJ, Sandusky, Ohio, Sandusky Register.  
 WMAJ, Lexington, Ky., Brock-Anderson Elect. Eng. Co.  
 WMAJ, Ann Arbor, Mich., Ann Arbor Times-News.  
 WMAJ, Dubuque, Iowa, Appel-Higley Elec. Co.  
 WMAJ, Mattoon, Ill., Cole County Tel. and Tel. Co.  
 WMAJ, Miami, Fla., Electrical Equipment Co.  
 WMAJ, New York, N. Y., Calvary Baptist Church.  
 WMAJ, Lincoln, Nebr., Am. Radio Co.  
 WMAJ, Abilene, Texas, West Texas Radio Co.  
 WMAJ, Muncie, Ind., Press Publishing Co.  
 WMAJ, Scranton, Pa., Scranton Times.  
 WMAJ, Hastings, Nebr., Gaston Music & Furniture Co.  
 WMAJ, Chicago, Ill., Riveter's Park, Walter A. Kuehl.  
 WMAJ, Houston, Texas, Rice Institute.  
 WMAJ, Mayville, N. D., State Normal School.  
 WMAJ, Marion, Kansas, Taylor Radio Shop.  
 WMAJ, Pittsburgh, Penn., M. H. Pickering Co.  
 WMAJ, Carthage, Ill., Robert E. Compton & Carthage College.  
 WMAJ, Galesburg, Ill., Lombard College.  
 WMAJ, Waterloo, Iowa, Black Hawk Elec. Co.  
 WMAJ, St. Louis, Mo., Radio Service Co.  
 WMAJ, Amarillo, Texas, Daily News.  
 WMAJ, Yellow Springs, O., Antioch College.  
 WMAJ, Scranton, Pa., Radio Sales Corp.  
 WMAJ, Hamilton, Ohio, Doron Bros. Elec. Co.  
 WMAJ, Schenectady, N. Y., Union College.  
 WMAJ, Urbana, Ill., Univ. of Ill.  
 WMAJ, Camden, N. J., Federal Inst. of Radio Telg.  
 WMAJ, Dallas, Texas, 485 also City of Dallas, Police and Fire Signal Dept.  
 WMAJ, Tarrytown, N. Y., Koenig Bros., Tarrytown Radio Research Lab.  
 WMAJ, Marietta, O., B. S. Sprague Electric Co.  
 WMAJ, Cape Girardeau, Mo., Southeast Mo. State College.  
 WMAJ, Grove City, Pa., Grove City College.  
 WMAJ, Lincoln, Nebr., State of Nebr.  
 WMAJ, Plainview, Texas, The Plainview Electric Co.  
 WMAJ, Houston, Texas, C. W. Vlek Radio Constr'n Co.  
 WMAJ, Atlanta, Ga., 400 and 485 Atlanta Journal.  
 WMAJ, Utica, N. Y., J. & M. Elec. Co.  
 WMAJ, Birmingham, Ala., Alabama Power Co.  
 WMAJ, Johnstown, Pa., Penn. Traffic Co.  
 WMAJ, Tecumseh, Neb., Ruegy Battery & Elec. Co.  
 WMAJ, College Station, Texas, Agricultural and Mechanical College of Texas.  
 WMAJ, Manhattan, Texas, Kans. State Agr. College.  
 WMAJ, Bay City, Mich., Ra-Do Corp.  
 WMAJ, New York, N. Y., Signal Corps, U. S. Army.  
 WMAJ, Waco, Tex.; 3000 miles; Weather forecasts 11 a m daily; musical concerts, daily, 1:30 p m and on Wednesday and Saturday evenings at 8; Sanger Bros.  
 WMAJ, Philadelphia, Pa., Wright & Wright, Inc.  
 WMAJ, Laredo, Texas, Worman Bros.  
 WMAJ, Canton, Ohio, Daily News Printing Co.  
 WMAJ, Dearborn, Mich., Ford Motor Co.  
 WMAJ, Detroit, Mich., 400 485, Evening News.  
 WMAJ, New Orleans, La., Loyola Univ.  
 WMAJ, Washington, D. C., Post Office Dept.  
 WMAJ, Newark, N. J., Westinghouse Elec. & Mfg. Co.  
 WMAJ, New York City, A. T. & T. Co.  
 WMAJ, Deal Beach, N. J., Amer. Tel. & Telg. Co.  
 WMAJ, Parkersburg, Pa., Horace A. Beale, Jr.  
 WMAJ, Washington, D. C., Nat'l Radio Inst.  
 WMAJ, Louisville, Ky., Darrell A. Downard.



# Report of Conference on Radio Standardization

Engineering Societies Building, New York, N. Y., January 12, 1923.

**T**HIS conference was called by the U. S. Bureau of Standards in cooperation with the American Engineering Standards Committee, at the request of:

The Institute of Radio Engineers.

The National Radio Chamber of Commerce.

The Radio Apparatus Section, Associated Manufacturers of Electrical Supplies.

The National Retail Dry Goods Association.

The American Radio Relay League, Radio Corporation of America.

Dr. F. C. Brown, Acting Director of the Bureau of Standards, presided.

Dr. J. H. Dellinger, Chief of the Radio Laboratory of the Bureau of Standards, showed how the widespread interest in radio had brought with it an increasing demand for uniformity and dependability in the radio service and apparatus. The lack of any such standardization has been brought to the attention of the Bureau of Standards by producer, distributor, and consumer. There has not previously been a concerted movement to introduce standardization by joint action of all radio interests.

Dr. A. N. Goldsmith, Secretary of the Institute of Radio Engineers, stated that while standardization involves the danger of stagnation and possible excessive monotony in the resulting product, it is only by a reasonable amount of standardization along wise directions that gross abuse of public confidence can be avoided. The purchasers of radio sets and the dealers who handle them are all entitled to protection against vague or misleading descriptions of apparatus which is bought and sold.

Mr. William H. Davis, President of the National Radio Chamber of Commerce, expressed the belief that the radio industry is today in a situation where it must be careful or else lose the respect of the public. Fortunately the industry has shown a desire to get together in reconciling cooperation and individuality.

Mr. J. M. L. Hogan, consulting radio engineer, emphasized the need for education not merely of the consumers but of the manufacturers and dealers, and perhaps of the engineers. Trouble can be avoided by all adopting the same language and describing things in the same way. Among the radio instruments needing standardization are wavemeters, condensers, inductors, telephone receivers, and loud speakers. Mr. Hogan expressed the hope that this conference would result in the formation of a national committee which would at least formulate standards of practice to be recommended.

Dr. P. G. Agnew, Secretary, American Engineering Standards Committee, described the function of that committee as

to the provision of machinery for passing from the stage of standardization by societies or associations to standardization on a national scale. This is accomplished through a sectional committee on which each organization having a real interest in the standard under consideration is given an opportunity to participate. It is provided also that there shall be a reasonable balance between the different interests involved, neither the manufacturers, distributors, nor consumers having a majority on this committee except by the consent of the others.

Admiral Ziegemeier, Director of Naval Communications, spoke of the interest of the Navy Department as a large user of radio equipment, and urged the importance of giving full consideration to radio communication with ships and other isolated places. Mr. K. B. Warner said that the American Radio Relay League is glad to assist in this development looking toward the betterment of the art, and expressed hope that they would be a definite help on account of their long practical field experience in the use of apparatus. Mr. William A. Fitzgerald told of the interest of the National Retail Dry Goods Association in the development of tests for the standardization of radio apparatus, particularly receiving sets. Mr. M. C. Rypinski of the Associated Manufacturers of Electrical Supplies, Radio Apparatus Section, expressed the view that the conference should turn its attention mainly to the standardization of radio apparatus and radio broadcasting itself rather than undertaking commercial dimensional standardization which might interfere with the development of the art. Mr. A. H. Griswold, of the American Telephone & Telegraph Co., spoke of the necessity of keeping problems of regulation separate from those of standardization.

The conference then proceeded to the consideration of the agenda, which consisted of the following questions:

(1) Shall a formulation of standards for radio apparatus and service be made?

(2) What type of standardization should be initiated; thus what general classes of apparatus or service, or what specific parts should be considered most important to include in such standardization?

(3) What features should be covered in formulating standards for radio apparatus.

(a) Methods of rating; (b) methods of testing; (c) dimensional standardization; (d) specifications for general requirements; (e) specifications for purchase; (f) specifications for safety.

(4) Should steps be taken to provide testing facilities?

(5) What shall be the procedure recommended for carrying out the

conclusions reached by this conference?

(6) What general recommendations should be made to a continuing committee should such a committee be established?

(7) What consideration should be given to related lines of activity? (e. g., standardization of terms and symbols).

After other brief talks on the need for standardization in radio by a number of the representatives present, it was voted that action should be taken toward the formulation of standards for radio apparatus and service.

The conference then proceeded to consideration of the procedure for carrying out the conclusions which it might reach. The discussion developed the fact that the procedure of the American Engineering Standards Committee is very suitable for the formulation of radio standards. A general discussion followed on the desirability of having a single sectional committee or two sectional committees, one for dealing with questions of nomenclature and methods of measurement and testing, the other for dealing with commercial standardization. It was voted that a single sectional committee should be formed to carry on all phases of radio standardization.

The conference then took up the question of sponsorship for this undertaking, it being required under the American Engineering Standards Committee procedure that one or more organizations be selected as sponsor to be responsible for the formulation of the particular standard or group of standards and to organize the sectional committee. The organizations suggested as sponsors were the Institute of Radio Engineers, the American Institute of Electrical Engineers, and the Bureau of Standards. A number of persons spoke, urging the sponsorship of these organizations, some favoring separate and others joint sponsorship. A motion to make the three organizations joint sponsors lost by a vote of thirty to eight. A motion to make the Bureau of Standards sole sponsor carried by a vote of twenty-six to sixteen. The Chairman pointed out the need of a more nearly unanimous selection on the part of the conference if this standardization project is to succeed. A motion to reconsider having carried, it was suggested that an informal vote on all possible combinations of the three suggested sponsors be taken. This informal vote resulted as follows:

A. I. E. E. and I. R. E.....	29
Bureau of Standards.....	19
I. R. E.....	17
B. S. and I. R. E.....	12
A. I. E. E., B. S. and I. R. E.....	7
A. I. E. E. and B. S.....	00
A. I. E. E.....	10

A formal motion that the American Institute of Electrical Engineers and the

Institute of Radio Engineers be selected as joint sponsors carried by a vote of thirty-two to five. On motion by Dr. Brown this vote was made unanimous.

Motions were carried leaving to the Sectional Committee the decision as to the type and scope of the standardization to be undertaken immediately, including the consideration of testing facilities and other related lines of activity.

Dr. A. N. Goldsmith and Mr. L. T. Robinson having consulted with one another in behalf of the Institute of Radio Engineers and the American Institute of Electrical Engineers, respectively, made a statement acknowledging the expression of confidence in the organizations shown by the action of the conference. They appointed the following advisory committee to assist in the organization of the sectional committee and the necessary technical sub-committees:

For the Department of Commerce, Dr. J. H. Dellinger and Mr. L. E. Whittemore.

For the Navy, Commander S. C. Hooper.

For the Army, Major L. B. Bender.  
For the National Radio Chamber of Commerce, Mr. G. H. Lewis.

For the Radio Section of the Associated Manufacturers of Electrical Supplies, Mr. M. C. Rypinski.

For the National Retail Dry Goods Association, Mr. Wm. A. Fitzgerald.

For the Pacific Radio Trade Association, Mrs. Max Loewenthal.

For the Consulting Engineers, Mr. J. V. L. Hogan.

For the American Radio Relay League, Mr. K. B. Warner.

As a representative of the Standardization Committee of the Institute of Radio Engineers and former member of the American Institute of Electrical Engineers Standardization Committee, Mr. Donald McNicol.

For the Institute of Radio Engineers, Dr. A. N. Goldsmith.

For the American Institute of Electrical Engineers, Mr. L. T. Robinson.

The action of the conference may be summarized by stating that it agreed unanimously (1) that standards for radio apparatus and service should be formulated, and (2) that a broadly representative national committee on radio standardization should be formed under the leadership of the Institute of Radio Engineers and the American Institute of Electrical Engineers following the procedure of the American Engineering Standards Committee.

Some Congressmen seem to think that radio can be laid out like pastures or grazing lands with neat wire fences which would keep the broadcasts and messages within the confines of a state. Two of them actually believe that State rights are involved in the White-Kellogg Bill and want local radio control left with the state governments. DX's, take notice!

Bathing by radio is one of the last broadcasts from the Public Health Service, but whether *ether waves* were recommended was not made known.



**T**HE remarkable efficiency, sharp-tuning, and responsiveness to distant signals of this form of inductance is due to:

1. Absence of wood, fibre, or any other insulating substance, from the magnetic field, thereby eliminating loss of energy through dielectric absorption.
2. Inductance is concentrated in one small space.
3. Dimensions and spacing of turns give lowest possible distributed capacity and maximum pure inductance.

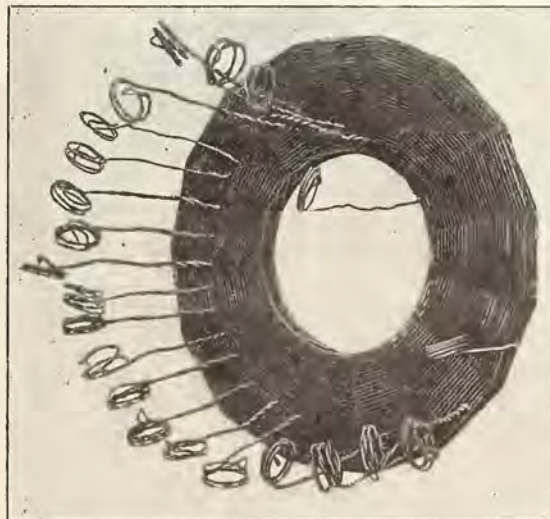

Tapped According to any Specification.

**PFANSTIEHL RADIO SERVICE COMPANY**  
Highland Park, Ill.

Chicago Sales Office, 33 So. Clinton St.  
Telephone: Franklin 2473.

# Symbols Used in Radio Diagrams

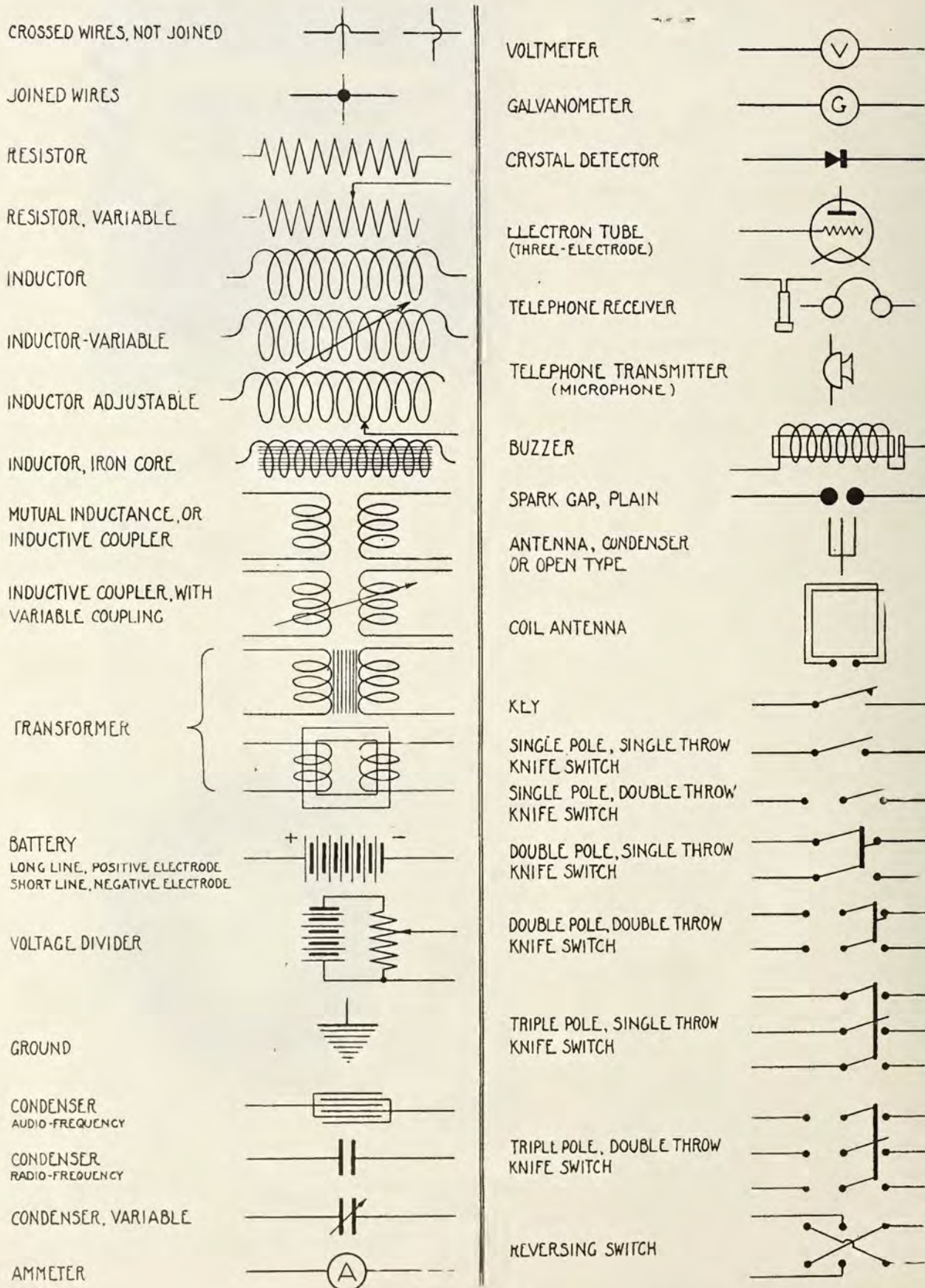

FIG. 4.

## Scribes Get New Set

A new Radiola Grand, one of the first of the latest developments in radio receiving sets made by the Westinghouse Electric Company, has been presented to the National Press Club in Washington. With this new set, which has a larger wave range and longer reception radius than the old set, many of the Washington correspondents whose papers broadcast, now tune in the "home station." Broadcasters in the Middle West and far South have been brought in since the new set has been in operation. Theodore Tiller, well-known representative of the Atlanta Journal, which broadcasts from WSB, was much disappointed the other day when told that he was paged by radio the night before. His paper put on a special program for him, announcing it over the radio and calling for him to listen in. He was not in the club, however, and missed out.

The Westinghouse Company plans to present new sets to several members of the cabinet interested in radio, according to Mr. E. L. Norcross, local representative, who has already installed a set for Secretary Weeks in the War Department.

The new installation is a big improvement on the old one-dial set, as it enables better tuning. It consists of a two-stage amplifier, transformer coupled, using a push and pull circuit on the second stage, which gives a smoother quality to the tone of the signals and eliminates a large amount of distortion. The loud speaker is also a new device and prevents "blasting." The horn and tubes are mounted on shock absorbers, and the tubes, which are of the now 1-2 volt variety, are operated from four dry cells. They are WD-11 tubes.

## Audion Amplifier

(Continued from page 14.)

to amplifier No. 2. The wire is reconnected to the "output" binding post of amplifier No. 1. The connections are now as shown in Fig. 3.

If the crystal detector is used in place of the electron tube detector unit the same general scheme of testing is followed.

### 8. Suggestions to Students.

The person who desires to study radio receiving sets further than what has been given in this series on very simple apparatus will find useful information in "The Principles Underlying Radio Communication," previously referred to, and in the periodicals and books listed in Bureau of Standards Circular, No. 122, "Sources of Elementary Radio Information." Both publications are obtainable from the Superintendent of Documents, Government Printing Office, the former at \$1.00 and the latter at 5 cents.

In text books and articles generally, the parts of radio apparatus are represented by conventional symbols. For the assistance of the student, Fig. 4 of this pamphlet shows the more common symbols which are extensively used in diagrams of apparatus and circuits. One should be familiar with these in order to read circuit diagrams.

## Havana-East Pittsburgh

Havana, like the rest of the world, is imbued with the wireless spirit and has any number of radio enthusiasts. Among those who "listen-in" nightly for the music and voices that fly through the air is J. W. White, Manager of the Westinghouse Electric International Company, with offices in the Edificio Banco Nacional de Cuba.

Mr. White has been a radio enthusiast since radiophone broadcasting was started on a large scale. It is a fact that almost every night, KDKA, the radiophone broadcasting station located in East Pittsburgh, Pennsylvania, U. S. A.,

about 1,500 miles away, as the crow flies, is picked up on Mr. White's receiver and the entertainment played so far away is enjoyed at the White residence. Three things are responsible for this extremely long-distance reception of radiophone broadcasting; great range of the sending station, the excellence of the receiver and the favorable atmospheric conditions that are found in Havana.

Mr. White uses a radio receiver known as the RC set manufactured by his company. It consists of a very sensitive tuner, with a vacuum tube detector and two stages of amplification. Many long distance records in radio reception have been made by this receiver but Mr. White's record is as good as the best.

*Make Your  
Crystal Set  
100% Eff*

*by Using*

# MPM

## Million Point Mineral

### The WORLD'S GREATEST RADIO CRYSTAL

THE discovery of M. P. M. has revolutionized the possibilities of ordinary crystal sets. Concerts have been clearly heard over 1000 miles. M. P. M. is super-sensitive—reproducing from every point on its surface. It increases audibility as well as radius and makes the purchase of an expensive tube set unnecessary.

Send 25c and name of your Radio Dealer for a sample M. P. M. crystal—concert tested and guaranteed.

DEALERS: Write today for our attractive sales proposition.

## M. P. M. SALES COMPANY

Dept. RA

247 S. Central Ave.

Los Angeles, Calif.

# With the Radio Trade

## Spider Web Coils

By EUGENE T. TURNEY

Imitation is the sincerest form of flattery, and the way some people have been exploiting Spider Web Coils, which I was the first to develop and patent, has somewhat stimulated my pride. It does not seem to be generally known that Spider Web Coils are a patented article, as is the machine with which they are wound, and that the name "Spider Web" is protected by trademark, all of which are controlled by my company.

Prior to 1921 little or nothing was known in this country of spiral or stagger wound coils and it was only after a trip I had made out West that it occurred to me that a coil properly constructed on these principles might prove efficient for radio purposes. While riding through the rural districts, my attention was attracted to the telephone wires crossing each other at stated intervals, and I resolved on my return to New York that I would consult an old friend of mine, a telephone engineer, who told me that if it were not for the crossing of these wires, long distance telephony would not be possible owing to the distributed capacity increasing as the line lengthened and that these crossings or transpositions had a strong tendency to break it up.

It occurred to me right then and there that an inductance coil constructed on this principle would be ideal for radio purposes. I learned the British had made some experiments along these lines without avail, which I found was due to the method employed in designing the core and laying on the wire. This failure, however, did not dampen my ardor and I set out to produce a coil I knew would be ideal, could the proper conditions be brought about, and whether or not I have succeeded can best be judged from the way Spider Web Coils, as I have named them, have leaped into prominence.

You will probably be interested to know that Spider Web Coils, when wound by hand, are no better than any other form of winding. The real merit in Spider Web Coils is produced by machine-spaced layers, which together with the proper number of transpositions reduces the distributed capacity more than any other known method.

For example, a coil of the duolateral type, having an inductance of 300 millihenries, will have a distributed capacity of about 21 micro micro farads, while a coil of the same inductance of Spider Web winding will have a distributed capacity of 4.6 micro micro farads, which is more than 500 percent less. You can readily see from the above that Spider Webs are much more efficient, owing to this difference. The lower the distributed capacity in the coil, the nearer you can approach a zero tuning with condensers in the circuits. It also means greater distance covered, more selectivity, less distortion and clearer signals.

There is as much difference between a

properly wound Spider Web and the ordinary form of winding as there is between day and night.

## Panels in Stock Sizes

Fifteen convenient stock sizes have been brought out by the makers of Radion panels. This is an addition of five stock sizes over the number they have been manufacturing for the past year. Developments in the radio industry have indicated that fifteen stock sizes fulfill almost every demand of the man who builds his own set, and greatly simplifies distribution by jobber and dealer alike. Beginning at the smallest panel, 6x7 inches, they appear in increasing lengths, such as 6x10 1-2, 6x14, 6x21, 7x18, 7x24, 11x12 and 12x14. The smaller sizes are 3/16 inches thick while the larger sizes, as 14x18 and 20x24, can be had in 3/16 and 1/4 inch thickness.

Neither the dealer nor his customer now has the waste and trouble occasioned by sawing panels from large sheets. The exact or approximate size of Radion panel, individually enveloped to protect the highly polished surface, with full directions for sawing, drilling, etc., can be selected and sold over the counter to the buyer. Radion panels are regularly supplied in two colors, black and mahogany, the latter being a beautiful imitation of genuine mahogany grain. The surfaces of both colored panels have beautiful satin-like polishes. An illustrated booklet may be obtained from the American Hard Rubber Company, 11 Mercer Street, New York City.

## Precision Sells Out

Powel Crosley, Jr., President of the Crosley Manufacturing Company, largest manufacturers of radio apparatus in the Middle West, announces that he has acquired the entire capital stock of the Precision Equipment Company, 2437 Gilbert avenue, Walnut Hills. It is the first financial deal of any magnitude in Ohio in which the principals are engaged in the manufacture of wireless telephony apparatus.

This announcement is of interest to

the more than 15,000 persons residing in Greater Cincinnati who are owners of radio-receiving apparatus, and of more than passing interest to the millions throughout the United States who possess these sets.

WMH, the broadcasting station of the Precision Equipment Company will be closed so far as the broadcasting of concerts is concerned, and hereafter the nights formerly used by that company will be used by the Crosley Company, which operates Station WLW.

## Homcharger Book

The Automatic Electrical Devices Company, 120 West Third Street, Cincinnati, Ohio, manufacturers of the Homcharger has recently issued a revised instruction book, which will prove quite valuable to any radio fan, whether he is using the Homcharger or not.

This booklet, besides the simple directions for operating the Homcharger, contains a paragraph devoted entirely to Storage Battery Maintenance. The information contained in this chapter will enable the radio fan to obtain the best service from his battery at minimum expense.

This booklet has been mailed by the publishers to all Homcharger users. Copies may be secured by any one interested for ten cents to cover cost of postage.

## Radion Panels

The manufacturers of the well known radion panels and parts for radio use have just announced that further improvements have been made in the composition of radion which produces an even better grade of material from the standpoint of its electrical and mechanical advantages. This improved product will be known, henceforth, as resiston-radion—resiston being the trademark adopted and registered by the American Hard Rubber Company, for sheet or moulded material compounded for electrical insulating purposes, including radio apparatus.

## This Coupon and \$2

Cut this out and send to Radio Age, 64 West Randolph Street, Chicago, Ill., and receive this magazine for one year. The regular subscription price is \$2.50 per year.

RADIO AGE,  
64 West Randolph Street, Chicago.

Enclosed find \$2 for which please send me Radio Age for one year.

Name.....

Street No. ....

City.....

State.....

# All-American Type R21—Ratio 5 to 1 Transformers Have Proper Impe- dances for WD-11 Tubes

—DRY CELL AUDIONS—

Our Type R-10 R.F. Trans-  
former operates extremely  
well with these tubes but it  
will be necessary to burn  
the filament slightly bright-  
er to obtain maximum  
R. F. Amplification.

**RAULAND MFG. Co.**  
25 So. Dearborn St., Chicago Ill

## LEARN RADIO

Here's your opportunity. Radio needs  
you. Win success in this fascinating field.  
Trained men in demand at highest salaries.  
Learn at home, in your spare time.

### Be a Radio Expert

I will train you, quickly and easily, to design,  
construct, install, operate, repair, maintain, and  
sell all forms of Radio apparatus. My new methods  
are the most successful in existence. Learn to earn

**\$1,800 to \$10,000 a Year**  
**FREE** Wonderful, home-construction, tube  
receiving set, of latest design.  
Write for "Radio Facts" free. Engineer Mohaupt,  
American Electrical Association  
Dept. 4513 Ravenswood Ave., Chicago

## CLASSIFIED ADVERTISEMENTS

Six cents per word per insertion, in advance. Name  
and address must be counted. Each initial counts  
as one word. Copy must be received by the 5th of  
month for succeeding month's issue.

### WANTED

Men—Women—Girls, 18 or over. Get U S Government  
Jobs. \$100-\$195 month. Steady. Short Hours. Common  
education sufficient. List positions obtainable—free.  
Write immediately. Franklin Institute, Dept. N117,  
Rochester, N. Y.

### PATENTS

Patents Procured and Trade-Marks Registered. Advice  
and terms upon request. Robb, Robb & Hill  
1413 Hanna Building. 952 McLachlen Building  
Cleveland, Ohio Washington, D. C.

### SALESMEN.

Salesmen that have been or are calling on electrical  
or radio trade, see Mr. Rice, 6311 N. Clark St., Chicago.



**The Homecharger**  
charges your  
AUTO or RADIO  
Battery for a Nickel  
Price \$18.50  
Send for FREE Bulletin  
Dealers—Write Now.  
The Automatic Electrical  
Devices Co.  
146 West Third St.  
Cincinnati, O.

## Broadcast by Birds

Letters to the number of 100 came to  
The Detroit News Broadcasting Station,  
WWJ, applauding the recent debut of  
six canaries which sang recently over the  
radio for that station. The letters all  
ask: "How did you do it?"

The time for each concert is of course  
limited. The time allotted to each enter-  
tainer averages five or ten minutes. So  
it was necessary that each bird should be  
sure to sing when his turn came on the bill.

Canaries are temperamental like other  
artists. Canaries sing when they are in  
the mood—not when you are.

"How were you able to make them  
sing in the WWJ studio when you were  
ready to broadcast?" is the question  
asked by most of the listeners.

The six little feathered foreigners all  
of which emigrated from Germany a few  
months ago were brought from a bird  
store to the studio in the afternoon of the  
day they were billed to sing. This, so  
they would become accustomed to these  
unusual surroundings.

When it was time to broadcast a  
microphone was placed near the group  
of six little cages. The cages themselves  
were not moved. Two of the birds had  
been selected as leaders, and their  
cages were placed in the midst of the  
other cages so that the leaders would  
have feathered friends on either side—  
so that they would be encouraged to sing,  
and thus lead others to sing.

A special microphone, using a single  
button of carbon, was rigged up for this  
broadcasting. This is more sensitive  
than the usual type of microphone and it  
picked up the soft, delicate throat tones  
of the especially trained rollers, as well  
as the stronger mouth tones of the  
warblers.

When the program director was ready  
for the canaries to sing, they were a bit  
shy. Then one of the artists began to  
play a few bars of piano music softly.  
That started them. One of the operators  
turned on his apparatus, and when the  
switch was opened, the birds began to  
sing.

The song of the birds transmitted  
clearly, and were heard by many listeners  
as the 100 letters of approval indicate.  
These letters came from nearly all parts of  
the continent.

The canaries singing in Detroit, proved  
interesting to a cat in Ann Arbor, Michi-  
gan, as related by a postal card from that  
city. It was signed "Your Ann Arbor  
Audience," and said: "We heard every  
trill of the canaries as clearly as though  
they were in the room with us. It was  
lovely. Our little gray cat sat up and  
took notice!"

This broadcasting also started im-  
promptu concerts in homes where there  
were other canary birds. G. E. Deuble,  
19, 340 Frazier Drive, Cleveland, Ohio,  
wrote as follows: "We have a canary  
bird, whose cage is in the room with our  
radio receiving set. This bird was a  
Christmas gift to my wife. We didn't  
know it could sing until the canaries at  
Station WWJ began. Our bird looked  
into the loud-speaking horn, twisted his  
head from side to side, and then started  
to sing himself."

## "UNITED" CONDENSERS AND TRANSFORMERS

### Give a New Joy to RADIO.

Approved and adopted by  
leading Radio Engineers



### Variable Condensers

43 Plate	\$4.50
23 Plate	4.00
11 Plate	3.50
5 Plate	2.75
3 Plate	2.25



### Audio Frequency Amplifying Transformer

**\$4.50**

Product of an \$800,000 plant,  
engineered by experts, produced  
by highly special precision-mach-  
inery, tested to the thousandth of  
an inch.

Ask your dealer for "United"  
Radio instruments.

Send for circular.

## UNITED MFG. and DISTRIBUTING CO.

536 Lake Shore Drive,  
CHICAGO, ILL.

# How to Tune Receiving Sets

By A. T. VAN DYCK

Radio Engineer of General Electric Company

The basic rule to be followed for best results in the tuning of a radio receiver is to understand what each control does, in a general way at least, and to use the controls in systematic and not haphazard manner.

It is not necessary to know the theory of gas engines to operate an automobile, but the driver must know at least what the function of each control is, to drive intelligently, and the more he knows the better he is able to drive. So with the radio receiver, an understanding of the general principles of the set and its controls is necessary in order to obtain good results consistently.

In order not to digress from the immediate subject of tuning, I shall have to assume certain things. First, that your apparatus is some good standard make, or if homemade is constructed and connected in one of the standard ways. Then I shall assume that your antenna system is properly installed—that the aerial is sufficiently high, not too long or too short, is well insulated and as clear of surrounding buildings and trees as possible; that the ground connection is a good one, and that all electrical joints in the aerial and ground wires are soldered.

## What Tuning Means.

Tuning, in the meaning of this article, is the process of adjustment of receiving apparatus to accord with a particular transmitting station, in order to obtain the greatest response to that station's waves. A radio transmitting station sends electric magnetic waves out through space in all directions. When a wire is elevated above the surface of the earth it is struck by the passing radio waves. Radio waves are really moving electric forces, just as waves in water are moving mechanical forces, and when they strike a wire they cause it to move, electrically.

The tuning of the aerial is for the simple purpose of so adjusting the aerial wire that it can vibrate electrically to the greatest extent possible.

An important thing to note about these travelling radio waves is that they have definite frequency, or in other words, a certain number of them pass the receiving aerial in a second. The exact number is determined by the adjustment of the transmitter. Since these waves travel at a certain speed, they must be a certain distance apart, which is called the wave length. So that, instead of saying that a station sends out waves 360 meters apart, we could just as well, perhaps more clearly, say that it sends out 830,000 waves a second.

These waves strike receiving aerials regularly and evenly one after another, and we want to have them vibrate the aerials as much as possible.

To do this we adjust the electrical length of the antenna to suit the frequency of the waves. Then the antenna will swing electrically as far as it can, de-

## Hook-up Ideas Are Worth \$1

EACH radio fan who experiments finds something about design or operation that will help his fellow fan. Send in your new hook-ups and other original devices, accompanied by clearly drawn diagrams. Radio Age will pay \$1 for all such original articles and drawings used. Text should be limited to about two hundred words.

pending upon the strength of the wave pushes.

Therefore, in radio receiving sets, changing the electrical length of the antenna is done easily by putting in the circuit some wire wound up into a coil, with some means provided for changing the number of turns used—for example, by a switch, or with some means for varying the electrical effect of the turns without actually changing the number of them.

## Changes Wave Length.

Also it is found that if there are connected in the circuit two metal plates, which are placed near to each other, but not touching, and one of them is moved, this changes the electrical length of the circuit. Such a device is called a variable condenser.

There are two somewhat different ways of connecting up the tuning devices which are in common use today. These are known as the single circuit tuner and the two circuit tuner. In the operation of a receiver based on either system adjustment of the tuner part is but half the problem. In addition, there is the detector, which is connected to the tuning part, and which changes the received high frequency current into one with a form which will operate telephone receivers. There are two kinds of detectors in common use today—the crystal, or mineral, detector and the vacuum tube detector.

## How to Operate.

The single circuit crystal receiver is of course the simplest to operate. In this there are only the tuning control and the crystal. The proper procedure in tuning this type is to set the detector in contact and slowly vary the tuning control until desired signals are heard, then adjust tuning and detector contact to maximum results.

It is very desirable to connect up a doorbell buzzer, a push button and a single dry cell battery so as to test the detector and set it in sensitive condition.

In the operation of detector vacuum tubes the adjustment of the tube to sensitive condition is done on most sets entirely by the filament rheostat, which controls the current through the filament, and therefore its temperature. Usually the tube will operate to some degree if the filament temperature is anywhere near right, but best signals will be obtained only after it is exactly right, which is accomplished after signals have been picked up. The filament must not be burned brighter than necessary.

Most sets using vacuum tube detectors have another feature added in connection with the tuner called regeneration which is valuable because it adds enormously to the sensitiveness of the set. It consists usually of a coil whose electrical relation to the tuning coil can be adjusted. This coil is called the tickler coil, or the intensity coil, or the regeneration coil. When this is provided on a receiver it gives one more adjustment to be made.

Consider a single circuit receiver using vacuum tube and regeneration. We have these controls, the wave length tuning, the regenerative coil, and the filament rheostat. Set the filament to as near proper brilliancy as it is possible to estimate.

## How to Adjust Controls.

The next step is to vary the wave length control over its range very slowly, listening carefully for the desired signals. When they are heard adjust the wave length control and the filament control to best results and then increase the regenerative or tickler control until signals are best, possibly slightly readjusting the wave length control, which may be affected by the change of the tickler.

The two circuit receiver, especially if provided with regeneration, is much more difficult to adjust. The major controls on a two circuit receiver are the aerial circuit—called primary—tuning, the secondary circuit tuning, the coupling between these two, the tickler, and the tube filament rheostat. In short, there are five controls to adjust. The most important and most critical one of these is the secondary tuning.

To pick up signals, set the coupling at or near maximum, the detector filament brilliancy properly, the primary tuning control at or near its lowest value, and the tickler at or near its lowest value. Then very slowly vary the secondary wave length control from zero to maximum. If signals are not heard, change the primary setting five or ten degrees and vary the secondary through its range again. This should be continued until signals are heard. If they are not heard increase the tickler some and repeat.



# Be a Certificated Electrical Expert

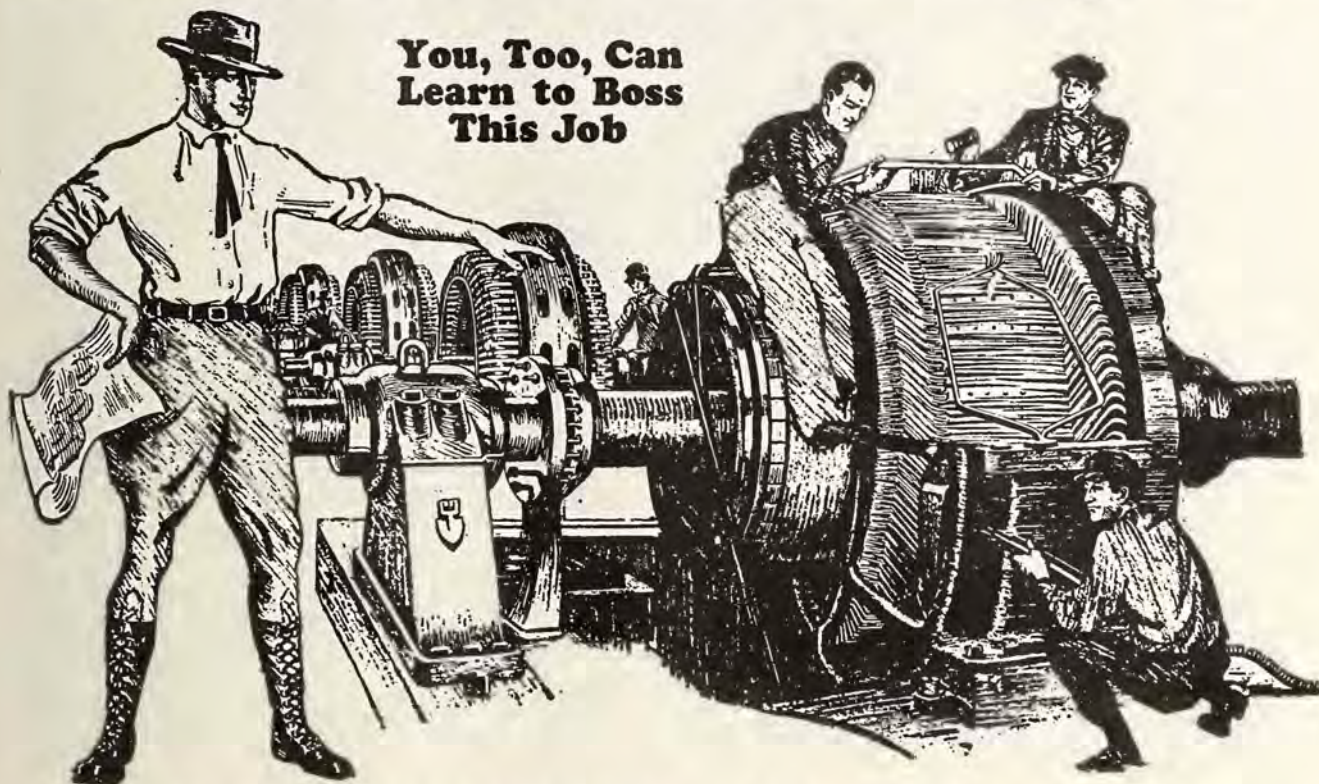

**You, Too, Can Learn to Boss This Job**

## EARN \$3500 to \$10000 a Year

Trained "Electrical Experts" are in great demand at the highest salaries, and the opportunities for advancement and a big success in this line are the greatest ever known.

"Electrical Experts" earn \$70 to \$200 a week.

Fit yourself for one of these big paying positions. In my twenty years of Electrical Engineering I have gathered some wonderful and interesting facts about this great industry—"Vital Facts." I will send them to you free.

### Learn at Home to Earn \$12.00 to \$30.00 a Day

Today even the ordinary Electrician—the "screw driver" kind—is making money—big money. But it's the trained man—the man who knows the why and wherefores of Electricity—the "Electrical Expert"—who is picked out to "boss" ordinary Electricians—to boss Big Jobs—the jobs that pay. You, too, can learn to fill one of these jobs—spare-time only is needed. Be an "Electrical Expert"—Earn \$70 to \$200 a week.

### Age or Lack of Experience No Drawback

You don't have to be a College Man; you don't have to be a High School graduate. If you can read and write English, my course will make you a big success. It is

the most simple, thorough, and successful Electrical Course in existence, and offers every man, regardless of age, education, or previous experience, the chance to become, in a very short time, an "Electrical Expert," able to make from \$70 to \$200 a week.

Materials and Measuring Instruments absolutely FREE. I also furnish them with all supplies, including examination paper, and many other things that other schools don't furnish. You do PRACTICAL work—AT HOME with this Outfit. You start right in after the first few lessons to WORK AT YOUR PROFESSION in a practical way.

### Some Features of My Course That Make SUCCESS Certain

1. Practical Money-Making Instruction—no useless, high-sounding theory.
2. Free Electrical Outfit.—Finest outfit ever sent out for home experiment and practical use.
3. Free Employment Service. (Helps you get a good job.)
4. Free Consulting Service. (No chance to get stuck on anything, while studying or afterward.)
5. Free Engineering Magazine.
6. Free use of my Electrical Laboratory.
7. Extra Courses Free—Radio—Electrical Drafting.
8. Spare Time Work—Special earn-while-you-learn lessons.
9. Reduced prices on all Electrical Supplies.
10. Cash Refund Guarantee Bond.

These features are all explained in my big Free Book.

### I Give You a Real Training

As Chief Engineer of the Chicago Engineering Works, I know exactly the kind of training a man needs to get the best positions at the highest salaries. Hundreds of my students are now earning \$3,500 to \$10,000 a year. Many are successful ELECTRICAL CONTRACTORS.

### Your Satisfaction Guaranteed

So sure am I that you can learn Electricity—so sure am I that after studying with me, you too, can get into the "big money" class in electrical work, that I will guarantee under bond to return every single penny paid me in tuition if, when you have finished my course, you are not satisfied it was the best investment you ever made.

### FREE—Electrical Working Outfit—FREE

I give each student a Splendid Outfit of Electrical Tools,

### Get Started Now—Mail Coupon

I want to send you the "Vital Facts" of the Electrical Industry including my Electrical Book, Proof Lessons, and a sample of my guarantee bond all FREE. These cost you nothing and you'll enjoy them. Make the start today for a bright future in Electricity. Send in the coupon—NOW.

**L. L. COOKE, Chief Engineer**  
**Chicago Engineering Works**  
Dept. 1689 2150 Lawrence Ave., Chicago

### Use this Free Outfit Coupon!

L. L. COOKE, Chief Engineer,  
Chicago Engineering Works, Dept. 1689  
2150 Lawrence Ave., Chicago, Ill.

Dear Sir:—Send at once the "Vital Facts" containing Sample Lessons, your Big Book, and full particulars of your Free Outfit and Home Study Course—all fully prepaid, without obligation on my part.

Name.....  
Address.....  
City and State.....  
Occupation..... Age.....

## The "Cooke" Trained Man is the "Big Pay" Man

## Tribute to Harbord

Following is a statement issued by Secretary Weeks, of the War Department, on the amendment to the army bill adopted by the House of Representatives for the purpose of depriving General Harbord of retired pay:

"It is most regrettable from the standpoint of the War Department and the public service that the House of Representatives adopted an amendment to the Army Bill which, in effect, takes from General Harbord, until recently Deputy Chief of Staff, his retired pay because he has become president of the Radio Corporation of America. The reason given for this action is that he has been employed by the company for the purpose of obtaining more business from the Government than the company could otherwise hope to secure. This is an insult to General Harbord and to the Government itself.

"For nearly forty years General Harbord has been faithfully and efficiently serving the Government and, regardless of what position he may occupy in civil life, the best interests of his Government will be his chief concern. Any inference to the contrary reflects on the person making it. As a matter of fact, the Government's business with the Radio Corporation is inconsequential. At the present time we have no contract with it, and, generally speaking, purchases of radio equipment, which are of small moment in total amount, are made from the manufacturers. But there is a much broader question involved in the action taken by the House.

"General Harbord, the son of a Western farmer, enlisted in the Army, starting his military career as a private at the beginning of the World War, at the age of fifty, he held the rank of Major. While his rank was not high, he had already impressed himself upon the War Department and his associates in the Army to such a degree that he was made Chief of Staff of the American Expeditionary Forces. He went from that position to the command of the Second Division, one of the most conspicuous fighting divisions in the Army. He commanded this division during the Marne-Vesle campaign.

"Things were not going satisfactorily in the Service of Supply and he was transferred, greatly to his regret, to the head of that service, a position of enormous responsibility and of the greatest importance to the Army. He so reorganized and conducted that service that he brought to himself not only the plaudits of his associates in the Army, but attracted the attention of men of importance in civilian life who were temporarily serving the Government in Europe; in fact, so extraordinary were his services and organizing ability that they have occasioned continual commendation from civilians since the war, and it was because of this capacity that he was called to the presidency of the Radio Corporation, as the most competent available man for that particular service in the United States.

## QUESTIONS

**F**OR those who miss the usual page of questions and answers in this issue of Radio Age the explanation is made that it is left out this month for two reasons, lack of space and the fact that answers to queries have been forwarded by direct mail. The questions and answers will be resumed in the next number. Meanwhile send in your questions and they will be answered as usual by Frank D. Pearne, technical editor of Radio Age. Enclose stamped and self-addressed envelope with your communications.

"The development of the radio is of vast public importance and there is, therefore, a public reason why he should accept and fill that position, retaining his place on the retired list of the Army so that he would be available for service in an emergency. If a British officer, French officer, or an officer of any other nation had performed for his government the service rendered by General Harbord, instead of having this stigma attached to him, the inference that he is dishonest—not to mention taking away his retired pay—he would have been given honors of very important character and certainly in the case of Great Britain, a large honorarium as well. I do not believe the people of this country wish its great defenders treated in such a shameful way, and I should think General Harbord would feel that a country that would tamely submit to such treatment of one of its officers was hardly worth serving. He will certainly feel a sense of injustice which time can never efface."

As amended, the Army appropriation bill provides that no officer, retired or in active service, employed by an organization doing business with the Government shall receive any of the funds carried. General Harbord, as well as many officers in similar circumstances, would receive no retired pay.

A study of the business conducted between the Signal Corps and the Radio Corporation reveals the fact that scarcely any business has been transacted for several months. Since the war it was not more than \$300,000 worth, when this organization was the only bidder. Today, however, the Signal Corps deals directly with the General Electrical, Westinghouse and other manufacturing companies, although the Corporation reserves the right to bid. During the calendar year the Signal Corps purchased electrical equipment valued at \$1,475,000, of which about fifty per cent was radio apparatus.

## Open Eastern Office

The United Manufacturing & Distributing company, manufacturers of the well-known United Condensers and transformers, announce that they have opened an eastern office at 50 Church Street, New York City, in charge of Arthur Deery.

## Radio vs. Crime

By Washington Radio News Service.

Attorney-General Daugherty plans a National Bureau of Identification and Information in Washington, and radio will be the means of broadcasting data on criminals and their activities to the whole country, according to William J. Burns, Chief of the Bureau of Investigation. This National Gallery of Rogues and Crime, the idea of the Attorney-General's, is believed to be something unique in criminal investigation as it will cover the whole country and be immediately available.

"In these days of preventative medicine, and fire and accident prevention," said Mr. Burns, America's foremost detective, "we have now come to crime prevention. We plan eventually to have on file here photographs, finger prints, descriptions and histories of every known criminal in America, as well as data on his methods of operation," he explained. When legislation authorizes it and the system gets into operation with state, county and municipal police departments cooperating, Mr. Burns believes we will have made the first practical step toward the prevention of crime and the apprehension of criminals.

If a local police department radios to Washington the details of a crime, together with a description and name of the suspect, or asks for data on a man in the rogues' gallery, it would be disconcerting for the fugitive from justice to know that a few minutes later, his whole history would be broadcast throughout the United States.

He would be watched for at every possible point of departure within an hour after the commission of the crime. Mr. Burns believes this would restrain, to a great extent, the activity of criminals.

Already one police association has voted to turn over its criminal historical data to the Washington National Headquarters, where the government records will soon be moved from Leavenworth, Kansas, as a nucleus of the criminal and rogues' archives, to be kept by the new division under Mr. Burns. Cooperation of all the states is anticipated as well as of all large cities, where radio broadcasting is rapidly coming into use.

A national bureau of identification will be of immense value to the country, Mr. Burns said, explaining that criminal psychology was such that when he is known, he is practically out of the game. "Turn the light on him, and he is destroyed," Mr. Burns put it. "Catch him, without his knowing how it was accomplished," he said, "he becomes uneasy and is thereafter slow to take a chance." Sir Basil Thomson, formerly head of Scotland Yard and a recent visitor in Washington, was most interested in the Department's scheme, Mr. Burns said. Sir Basil is also a firm believer in the value of radio in general police work.

Send \$1.00 to Radio Age, 64 Randolph Street, Chicago, and receive this middle-west radio periodical for six months. Regular subscription price is \$2.50 a year.



**“SENSITONE”  
Regenerative  
Radio Receiving Set**

**\$15**

**DOWN  
AND \$10.00  
PER MONTH  
Immediate Shipment**

*Manufactured under Armstrong License, U. S. patent No. 1,113,149 and pending letters of patent No. 807,388*

**READ THESE TESTIMONIALS!**

Harold R. Waken Co  
Chicago, Ills.

Seaton, Ills., December 22 1922.

Chicago, Ills  
Atlanta, Ga.

Newark, N. Y  
Detroit, Mich.  
Minneapolis, Minn.

Dear Sirs:

Following is a report of the different stations I received on the Sensitone Detector, and all came in very clear, on the 21st.  
Ft. Worth, Texas  
Davenport, Iowa  
Cincinnati, Ohio  
Indianapolis, Ind  
Pittsburg, Pa.  
Kansas City, Mo.

Memphis, Tennessee.  
Dallas, Texas.  
St. Louis, Mo.  
Louisville, Ky.  
Schenectady, N. Y.  
Denver, Colo.

I did not go to bed until 3 a. m. next morning. Certainly is a fine machine. Hope to add Amplifiers and Loud Speaker in near future. I am getting stations that other radio bugs here in town don't get. 12 radio sets in town at present. 400 population, and lots of bugs here. You can use my name if you choose

Yours truly,

D. E. HAIST,  
Seaton, Ills.

Telegrapher, M. & S. T. L. R. R.

Harold R. Wakem and Co.,  
Chicago.

Dear Sirs:

Last night was the first night that I tried my Sensitone, and here are some of the stations that I heard very well: Houston, Texas; Denton, Texas; Fort Worth, Texas; St. Louis; Dallas News; Cincinnati; Atlanta Journal; Detroit News.

I heard ever so many others, that I just tuned in or out as they interested me or not. Now, don't you think that's a good start for a green beginner? According to what I have read I am living in the "home" of stations

and I am sure there was lots of it yesterday, as it was very warm, and we had a lightning storm also.

I listened in to the St. Louis Post-Dispatch for over an hour, as the concert was fine, and everything was clear. Yesterday afternoon at three I heard Houston, Tex., very well.

Detroit is a mighty long distance from here, so I consider your set a marvel.

With all good wishes for the coming season I beseech to remain  
Yours sincerely,

REV. JOS. J. BOUDREAU.

December 13, 1922, 9:49 p. m.  
DB 841, 49 Collect N.L., Lubbock Tex 13  
Harold R. Wakem & Co., Chicago, Ill.

In answering queries relative distance performance he explicit without fear quote this telegram first night's program included Detroit News, Drake Hotel, Chicago, Kansas City, Davenport, Atlanta, Paducah, Ky., Los Angeles, San Antonio, Houston, Ft. Worth, Oklahoma City, entire cotton, cattle, hog, sheep markets from Kansas City. Two p. m.: Is more than satisfactory with thirty foot aerial. W. H. WARD, Theriot, Louisiana, December 10, 1922.

**ONLY 500 SETS SOLD ON  
THE EASY-PAY PLAN**

We are making this rather costly investment in order to get 500 sets in the hands of that number of influential families, so that, when we put our goods in the hands of dealers, they may have enthusiastic SENSITONE boosters nearby to whom they can refer their future prospective buyers.  
Fill out the coupon, attach check or money order for \$15.00. Set will be shipped at once by express. Those who delay will be too late.

**Harold R. Wakem & Co.**  
900 Washington Blvd. CHICAGO

HAROLD R. WAKEM & CO.,  
900 W. Washington Blvd., Chicago, Ill.

Enclosed you will find \$15.00 as first payment, upon receipt of which you will send me your complete Sensitone Radio Receiving Set, as described above. After I have used the set for thirty days, I agree to send you \$10.00 and the same amount every thirty days thereafter, until the full purchase price of \$95 is paid. This set is to remain the property of Harold R. Wakem & Co. until payments are completed.

Signed.....  
Street address.....  
City.....  
In the spaces below give the names of two references, (banks or business houses preferred)  
Name and Address.....  
Name and Address.....

Tell 'em You Saw It In "Radio Age"

# Reinartz Radio

How to make this distance wrecker.  
How to amplify it.  
How to make a Reinartz panel.

## *With Hook-ups*

---

Written and Illustrated by  
FRANK D. PEARNE

*Chief Instructor in electricity at Lane Technical High  
School, Chicago, and famous writer on radio  
construction and operation.*

---

Hook-up for the Long Distance Cryst-  
tal Set—They are all trying it.

Other articles on latest radio angles  
fully illustrated.

*Get this book of the 1922-23 Season*

Published by  
**RADIO AGE, Inc.**  
64 West Randolph Street  
CHICAGO

*AT YOUR NEWSDEALERS' OR SEND MONEY ORDER  
OR CURRENCY TO PUBLISHER*

— Price 50 cents —

# Scanned from the collections of The Library of Congress



Packard Campus  
for Audio Visual Conservation  
[www.loc.gov/avconservation](http://www.loc.gov/avconservation)

Motion Picture and Television Reading Room  
[www.loc.gov/rr/mopic](http://www.loc.gov/rr/mopic)

Recorded Sound Reference Center  
[www.loc.gov/rr/record](http://www.loc.gov/rr/record)

**This file including all text and images are from scans of a private personal collection and have been scanned for archival and research purposes. This file may be freely distributed, but not sold on ebay or on any commercial sites, catalogs, booths or kiosks, either as reprints or by electronic methods. This file may be downloaded without charge from the Radio Researchers Group website at <http://www.otrr.org/>**

**Please help in the preservation of old time radio by supporting legitimate organizations who strive to preserve and restore the programs and related information.**