

On the Air

A Magazine of Radio

February
1926

15
cents



Featuring Our 1926 R F Receiver

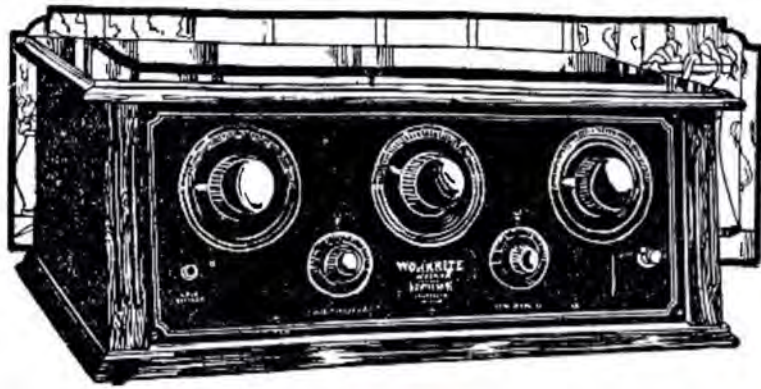

WORKRITE WINNER FIVE

Here is a Receiver that is taking the country by storm. Think of the great value in a genuine licensed Neutrodyne Receiver, five tubes, a beautiful dark brown walnut cabinet, sloping panel and knobs to match, gold trimmings, battery cable, everything of the latest and best, at \$80. The WORKRITE WINNER FIVE will easily bring in stations at unbelievable distances with great volume and wonderful tone quality. The WORKRITE WINNER is the outstanding value in radio this year. Test it against other sets selling for much more. PRICE \$80.

DEALERS—GET OUR ATTRACTIVE PROPOSITION

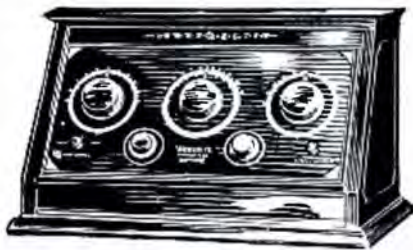

Workrite Air Master Six

A six tube resistance-coupled Neutrodyne with absolutely true tone quality without distortion. Mahogany panel and knobs to match cabinet. Gold trimmings. WAVE LENGTHS SHOWN ON PANEL—you can turn to any station almost instantly. As one customer said: "I never heard real radio until I listened to this marvelous WORKRITE." PRICE \$125

Workrite Radio King Six

A six tube resistance-coupled Neutrodyne. To appreciate the beauty and performance of this remarkable set, you must see and hear it. A very artistic cabinet made from genuine mahogany with special loud speaker built in, will give the utmost radio enjoyment. PRICE \$170

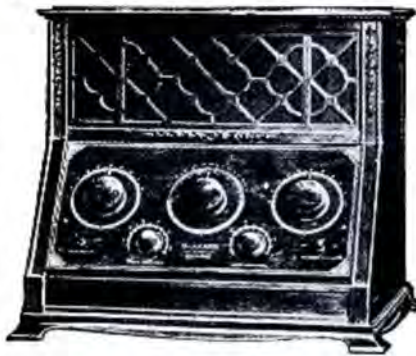

Workrite Aristocrat Six

The best in a set in the finest mahogany console. A radio you will be proud to own. Its beauty is only equaled by its performance. Six tube, resistance coupled. PRICE \$275

Write for beautifully illustrated folder

Reg. U.S. Pat. Off.
Licensed by
Independent Radio Manufacturers, Inc.
NEUTRODYNE
Pat. March 27 1923 and April 1 1926
Merch. Pat. Nos. 1 450 080 and 1 468 278
Other Patents Pending.

THE WORKRITE MFG. CO.
1816 E. 30th Street Cleveland, Ohio

Branch Office: 536 Lake Shore Drive, Chicago, Ill.

Reg. U.S. Pat. Off.
Licensed by
Independent Radio Manufacturers, Inc.
NEUTRODYNE
Pat. March 27 1923 and April 1 1926
Merch. Pat. Nos. 1 450 080 and 1 468 278
Other Patents Pending.

WORKRITE

SUPER NEUTRODYNE RADIO SETS

New Coil startles Radio engineers.

laboratory and practical tests prove it **31%** *More efficient than any other coil.*



For three years Cruver's chief engineer worked on this revolutionary idea for a low loss coil. Tens of thousands of dollars were spent in experimental work alone. And now, for the first time, the fruit of his labor is available to every one.

Every radio engineer knows that insulation increases high frequency resistance and distributed capacity. But it was for Cruver's engineer to invent a coil free from the usual insulation.

Selectivity Never Known Before

The design and construction of this coil accounts for the extreme selectivity so important to set owners who demand the utmost in performance regardless of location. Stories of the accomplishments of sets equipped with the Proudfoot coil have already led to a large volume of advance orders from radio experts in all parts of the world. Never since radio became popular has any radio part created such a sensation.

"Revolutionizes Radio Reception"

say Engineers

The Proudfoot coil has been tested in various laboratories by seventeen engineers. The results have uniformly proven that it is 31% more effective than any other coil. In writing of the Proudfoot coil the professor of radio in Chicago's largest institute of technology says "After exhaustive tests, I am convinced that the Proudfoot is far in advance of any coil I know of."

If your dealer cannot supply you with the Proudfoot coil, order by attached coupon.

CRUVER MANUFACTURING COMPANY

2456 W. JACKSON BLVD.

CHICAGO, ILLINOIS

Tell them you saw it advertised in On the Air.

Unique Features of LOW LOSS

PROUDFOOT COIL

Air core frame of one piece moulded bakelite.

8 strong bars absolutely preventing sag or warp.

Wire held rigidly in position and spaced by means of grooves on bars. May be mounted on baseboard or back of Proudfoot condenser.

Made for condensers of the following capacities: .00025; .00035; .0005.

Recommended for any tuned R. F. set. Set of three matched coils . . . **\$15.00**

PROUDFOOT KIT

consisting of 3 Proudfoot coils and 3 Proudfoot condensers carefully tested and matched. Hook-up blueprint and instructions.

\$26.70



CRUVER MANUFACTURING COMPANY, Room 200—Cruver Building, 2456 W. Jackson Blvd., Chicago, Ill.

Please send me C. O. D., the instruments checked below, for which I will pay postman price indicated plus postage.

3 Matched Proudfoot Coils (check capacity desired) .00025—; .00035—; .0005— (Price \$15.00).

Proudfoot kit of 3 matched coils and 3 condensers with hook-up blueprint. (Price \$26.70)

I understand that I may return these goods in 30 days for full refund if they do not prove entirely satisfactory.

(Name)

(Address)

If you send cash with order we will pay postage.

On the Air

A Magazine of Radio

VOLUME II

NUMBER VI

Contents

February, 1926

Cover Design in Oils.....	By Anker Mehlum	
The Freedom of the Air is Questioned.....		7
A Perfect Loudspeaker at Last.....		9
By Armstrong Perry		
The Weather Report.....		11
By S. R. Winters		
The National Fading Tests.....		13
By George A. King		
Radio Conquers the Arctic.....		15
By H. H. Roemer		
The World at Your Fingertips.....		17
By Burton Synott		
Four Pages of Late News Pictures.....		21
Last Minute News from Congress.....		30
How Your Coupler Works.....		31
By A. J. Kramer		
Our 1926 Model Radio Receiver.....		33
By The Technical Staff		
How to Use Tube Reactivators.....		00
By Radio Operator 39,736		
A Talk on B Eliminator Systems.....		37
By A. J. Strong		
Feedbacks by Our Readers.....		40
Comparing the Three Audio Systems.....		41
By Glenn H. Browning		
Technical Editors Advice to the BCL.....		43

SCANNING THE CONTENTS PAGE

The freedom of the air is questioned. An exclusive story written by our new editor on an important question in radio. Quite a scoop.

Armstrong Perry in his meanderings around the country has discovered the "perfect" Loudspeaker at last. He tells about it in his inimitable way, a feature that is tremendously interesting and newsworthy.

S. R. Winters one of our staff writers has interviewed the head of the Weather Bureau at our request in an effort to determine the value of the much scoffed weather report. His report should help us to place a value on this branch of radio service.

H. H. Roemer has written a colorful story on the MacMillan Expedition, discussing it from a heretofore unappreciated angle. He recounts some interesting work done between stations WNP and 9XN of the expedition.

We visit a real honest to goodness amateur station and manager to get the owner away from his key long enough to tell us about some of his experiences. Talk about thrills—well, read the story.

Our offerings in the technical department of this issue are unparalleled for their authoritativeness. A. J. Kramer discusses selectivity and couplers, Glenn H. Browning, the inventor of the Browning Drake circuit compares audio systems and A. J. Strong gives valuable information on B eliminator systems.

It is our modest belief that you are going to have trouble in deciding which feature you prefer to read first, and we'll bet that you'll never be able to decide which story you like best.

And wait till you see our next issue!

H. J. MEISTER,
—Publisher.

Publication Office 404 N. Wesley Ave., Mount. Morris, Ill.

Published Monthly by

On The Air Publishing Co., Kimball Hall, Chicago, Ill.

Henry J. Meister.....Publisher
Felix Anderson.....Editor
Howard I. Shaw.....Advertising Manager
Frank O. Balch.....Circulation Manager

Advertising Representatives
RHODES & LEISENRING
Bell Building, Chicago

ON THE AIR is published monthly by ON THE AIR PUBLISHING CO., 1322 Kimball Hall Building, Chicago, Ill. Application made for transfer as second class matter from the Post Office at Chicago, Ill., to the Post Office at Mount Morris, Ill., under the act of March 3, 1879. Originally entered at the Chicago Post Office April 25, 1925.

ISSUED MONTHLY 15 cents the copy, \$1.50 a year in the United States and Possessions. Elsewhere \$2.00. When remitting do so by check, money order, or by registered mail if cash is enclosed.

Advertising forms close on the 15th of the month preceding date of issue. That is, forms for the February issue close January 15th. Issued on or about the 25th.

Change of address. Instructions for the change of address should be sent to the publisher at least two weeks before the date of effect. Address all mail to ON THE AIR, 1322 Kimball Hall Building, 306 S. Wabash Ave., Chicago, Ill.

Copyright 1925 ON THE AIR

selectivity — tone quality



The DeLuxe Model Pontiac Radio for those of discriminating taste.

A Radio

that combines all desirable features

—at a reasonable price

The Pontiac Radio set is all you could ask of a radio. It is designed to tune with the greatest selectivity, and yet so assembled that it does not sacrifice tone quality. It brings in the broadcast programs as clearly and plainly as though you were present in the studio. Its tones rival and exceed the original transmission in beauty.

The performance of the Pontiac Receiver is consistent and reliable, because each set is laboratory tested, and each individual unit of its assembly is rigidly inspected and tested

before and after its embodiment in the finished radio.

Technically, the Pontiac Radio is a five tube set incorporating the latest tuned radio frequency circuit. A 1926 radio designed to meet the present day requirements. Its tuning range is from 200 to 550 meters, pro-

viding reception on all existing broadcast wave bands.

The discriminating buyer will choose the Pontiac radio because it will harmonize with the appointments of his home.

You owe it to yourself to investigate this exceptional radio set. We have a special limited offer in mind for the first hundred prospects who fill out the coupon below and mail it without delay. There is no obligation—we merely want the privilege of acquainting you with this wonderful set.

PONTIAC RADIO CO.

25 East Jackson Blvd.
CHICAGO, ILL.

PONTIAC RADIO

selectivity ✦ tone quality

Pontiac Radio Company,
25 East Jackson Blvd.,
Chicago, Illinois.

Gentlemen:

Please send me full information and prices on the New 1926 Model Pontiac Five tube Radio

Name.....

Address.....

City..... State.....

Tell them you saw it advertised in On the Air.

EDITORIALS



RADIO is at last taking on the aspect of going through a process of stabilization. In every department we find that research is being carried on in an effort to systematize the various details of this great industry into a smooth working unit. It is interesting to itemize a few of the progressive undertakings—all of them with the object of making radio pleasanter, broader in its scope, and more efficient in its purpose.

First of all, we notice that Congress is busy considering legislation that will govern the future of radio broadcasting, the danger of monopolies, and unforeseen developments. It is timely and necessary that this matter has been given an audience by our lawmakers.

In the technical departments we have the welcome steps toward standardization of radio equipment. A group of sincere and progressive manufacturers have organized an association and appointed committees to undertake the work of deciding universal sizes for our accessories, so that we may assemble a radio in the future with the assurance that the dial we like will fit the tuning unit shaft we choose. Anyone who has experienced the disappointment of finding that his purchases did not match can well appreciate this movement on the part of the manufacturers and designers of radio equipment.

In broadcasting, we notice that experiments are being conducted with a new crystal, and appropriate circuits for its employment, that will eliminate the annoying heterodyne whistles we have endured in our programme reception, caused by one station deliberately or inadvertently getting off their assigned wavelength and encroaching on the frequencies assigned to another station higher or lower on the dials.

There has been a distinct trend toward better programs as the popular high grade "chain" broadcasts will abundantly testify. The diversified programs broadcast by Tom, Dick and Harry are not so much of a conglomerate of this and that as they used to be. The chain broadcasts have created the desire for unified programs, and nowadays a radio fan can tune in a station with the assurance that a selection from a popular opera will not be immediately followed by a jazz selection of suggestive calibre.

These are but a few of the major advances we have made in the past few months. It shows in spite of the numerous knockers who predict "radio is going to the dogs" that radio is getting better and better every day, even though the progress is so slow that only the most experienced and critical can detect its progressive tendencies.



The editorial policy of ON THE AIR is one that dovetails with the progress of radio more perfectly than any other journal in the field. We are endeavoring to perfect the various units of our magazine with the object that it may render the broadcast listener and radio in general, greater service. Suggestions as to how we may improve our method of exemplifying this policy are welcomed. As radio fans and readers you enjoy a point of view that cannot be appreciated unless pointed out.



We should like very much to see a group of progressive advertisers of radio sets and accessories get together and decide to take the superlative out of their advertising. We hope that in the near future we may see a select group of manufacturers assemble with the purpose of standardizing selling methods so that the "gyp" artist will find himself sorely pressed for room in the radio market. This could be accomplished by establishing a general selling agreement whereby the extravagant claim "this set will work anywhere, anyplace, anytime and get anything" will be somewhat seasoned by a little truth. Every radio manufacturer who builds a decent set knows that the results obtained by that set are more or less of a gamble, the odds lying in the operating location of the set, the accessories and last but not least, the atmospheric conditions in the vicinity where the set is operated. It certainly would be refreshing to see an advertisement read "this set will give satisfactory results in a location suited to radio reception." It would necessitate the buyer's appraising his location, and would of course influence his choice of an appropriate set.

Free!

REVISED Edition of "On the Air" Radio Log and Call Book!

What Every Radio Fan Needs!

- List of broadcasters, alphabetically by call letters.
- Broadcast map.
- Broadcasters alphabetically by cities.
- Class "B" stations by wavelength.
- Foreign broadcasting stations.
- Radio station log.
- Helpful suggestions on construction and operation of radio receivers.

HERE is the most complete Radio Log and Call Book ever issued! It is a complete book of radio information, containing valuable technical information essential to the proper operation of a receiver, batteries, tubes, etc., as well as interesting, up-to-date items of importance. Profusely illustrated with maps, pictures, etc.

NO other book is printed like this one! Handy pocket size. It is useful to every owner of a receiver. You need it, and we'll be pleased to mail it to you free of charge with a year's subscription to ON THE AIR, at \$1.50, postpaid. Send in your order at once, for the edition is limited, and we want all our friends to get a copy of this unusual book. Just clip the coupon today.

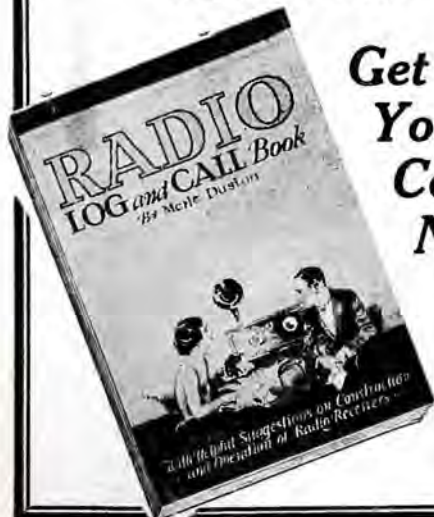

**Get
Your
Copy
Now!**

ON THE AIR,
Kimball Hall, Chicago, Ill.

Enclosed find \$1.50 (cash, money order or certified check) for which you may send me ON THE AIR for one year, beginning with the current issue, and the new edition of the Radio Log and Call Book FREE.

Name

Address

(2-26)

Tell them you saw it advertised in On the Air,

Moments When Radio Counts



Kadel and Herbert

THIS sinking ship, the Italian freighter "Ignacio Florio," would have been lost with all aboard had it not been for a radio SOS. All nearby broadcasters signed off to permit reception of the SOS, as is the custom, and the American Liner "President Harding," went to the rescue. The lifeboat from the American ship is shown taking the last members of the crew off just before the Italian liner sank beneath the waves.

On the Air

A Magazine of Radio

FEBRUARY, 1926

The Freedom of the Air Questioned

Station Resorts to Direct Action to Bring
About Friendly Litigation to End Wave Chaos

By THE EDITOR

ON January 18, 1925, Station WJAZ came on the air and started something. According to the dictates of the Secretary of Commerce and the rules and regulations of the Bureau of Navigation they were operating illegally, and are subject to prosecution and punishment. By all existing rules and laws, if there are such, Station WJAZ becomes outlaw, because they have disregarded the time allocation and wavelength assignment given them by the Secretary of Commerce.

On the other hand, Station WJAZ maintains that they are not violating any definite laws affecting radio broadcasting. They insist that they are merely taking a stand against the discretionary powers vested in the Secretary of Commerce by virtue of the existent radio laws passed in 1912. It is their object to bring about definite action that will necessitate legislation to bring about changes in the system of broadcast control that will make for greater satisfaction among the listeners, especially those located in districts where there are numerous broadcasting stations.

Looking at the matter impartially, it is fortunate for radio that something like this has developed. It is generally agreed that too much interference exists under the present scheme of things. Whether this is the fault of the Secretary of Commerce remains to be seen.

Allocating Waves Terrific Task

THE Secretary of Commerce has a gigantic problem to cope with in his work with radio broadcasting trying to satisfy

both the broadcaster and listener. He has our genuine sympathy because we feel that he is applying the laws to existent conditions judiciously and well. We feel grateful for the years of wonderful entertainment that his management has enabled us to enjoy. There is a definite need for more rigid impartial and specific laws that confusion and chaos may be eliminated in the future from radio. It is quite plain that some definite stand must be taken in the matter of license assignments and something must be done in the matter of the heterodyning that exists, especially on the lower wave stations.

If the Secretary of Commerce can apply the discretionary powers vested in him in such a manner as to eliminate the interference and trouble, in order that the broadcast listener may enjoy perfect service, then there is no need for further legislation. Recently he did this for the amateurs. By according the amateur definite and rigid specifications effecting their activities on short waves, he pleased them very much, pleased the commercial interests and protected government interests on the new bands.

Discretionary Powers

THERE is some question as to the wisdom of vesting discretionary power to the extent given the Secretary of Commerce, when it concerns so great and important a department of our everyday existence. When this question is raised there is always the murmur of "czar," insincerity, graft and other charges. The thing to do is

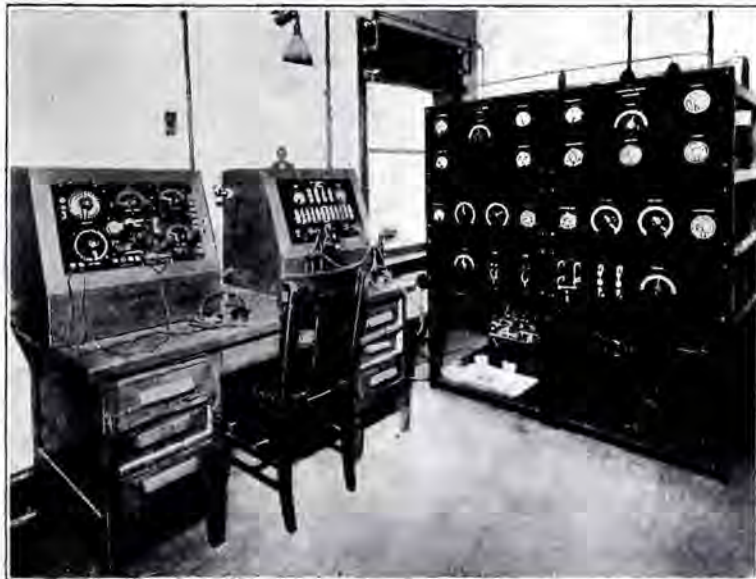

How much power does the government have in controlling stations? Are the laws definite and specific enough to cover violations? The present conditions point out that there are either too many stations or else they are not properly allocated in wavelength.

to criticise constructively. We don't want mud throwing in the radio game—rather we need intelligence and broadmindedness so that a satisfactory solution to the problem may be effected.

We are glad for radio and radio enthusiasts that a company as sincere as Zenith takes a stand in this test of government control. We hope that the litigation, if there is such, will be conducted on a friendly basis, always keeping the matter of service to the radio fan uppermost and foremost in mind throughout the entire incident. The effect of the actions taken by both parties involved in the matter is what is most important in the long run, and this general effect must be progressive to the interest of the radio fan if broadcasting is to continue successfully.

The history of the case is interesting and should be familiar to all radio fans. A brief resume of the affair is as follows:

Station WJAZ has for some time been endeavoring to effect some sort of an agreement with the government for what they consider a "fair" assignment of time and wavelength. After several unsuccessful attempts to have the merit of their station recognized they started broadcasting without official permission, after notifying the Bureau of Navigation of their intentions.

In defense of WJAZ activities, Commander Eugene F. McDonald president of the Zenith Radio Corporation, the owners of WJAZ, issued the following statement which was broadcast over the air on January 18, 1925. Excerpts of this statement are as follows:

Statement of Commander E. F. McDonald

"My attention has been called to articles appearing in the public press, from which it appears that the United States Government is about to institute some sort of legal proceedings against Zenith Radio Corporation, of which I am President, with the idea of punishing the Corporation or certain of its employees for operating its radio broadcasting station WJAZ for more than two hours per week, the time allotted it by the Secretary of Commerce. If the Government does take some action it will not be a surprise to us as we notified the Government authorities that we intended to go on the air for the purpose of making a test case in order to determine whether or not there is such thing as "freedom of the air."

Before doing this we made every effort to obtain from the Secretary of Commerce some fair and reasonable division of time. I spent weeks in Washington with my attorney Irving Herriott, pointing out the various channels that were open. All our efforts met

with failure. The Department even arbitrarily refused to permit us to use a wave length that another station enjoyed and offered to us. We feel that not only we, one of the pioneers in radio broadcasting, but scores of other stations have been discriminated against.

Causes of Congestion

THE present chaos and congestion in the air which makes it almost impossible for the listener with the average radio set of limited selectivity to separate one broadcasting station from the other, is not due to the great number of broadcasting stations in the United States, but is the result of the abuse of the discretionary power which the Secretary of Commerce claims to have in the division of wave lengths and operating time.

As a further indication of the extent of this unjudicious use of discretionary power, I want to point out the fact that the Secretary of Commerce, has licensed 27 broadcasting stations on one particular wave length, yet permits other stations to enjoy an exclusive wave length with no time limit. It is obvious that 27 stations cannot operate simultaneously, on one wave length, and be heard. In our own particular case he has licensed us to operate only two hours each week and has licensed another station to operate on our wave length the re-

maining 166 hours each week, and even our little two hours is subject to cancellation. The public is justly complaining about the congestion, yet if there were an equal division of time and wave bands, all could be heard and the public would receive real service without interference.

The radio public today is fully aware of the fact that certain interests now claim to have what virtually amounts to a monopoly of many exclusive wave bands. In my opinion any institution other than one whose business is to disseminate news should have nothing which approaches an exclusive right to any wave band. News agencies are in the nature of public utilities, and their use of the air is of vital interest to the public generally. Such broadcasting should necessarily be given preference over music and other entertainment, but I say that none other than such should be given preference.

With the idea of settling one of the greatest questions presented by the development of modern science, Zenith Radio Corporation intends to litigate in every way possible the questions involved. We naturally desire a reasonable division of time for our own broadcasting station, but if we can by litigation settle the question of freedom of the air and a fair and equitable

(Please turn to page 49)



HOW THE DAILY PRESS TAKES IT
The daily press finds the matter of "pirate Broadcasting" an excellent feature for their hungry radio feature pages. The above are clippings from Chicago dailies showing the intense interest centered on the question.

A Perfect Loud Speaker at Last!

Q Noted Washington Inventor Perfects the "Titanafram," Which He Claims is the "Last Word" in Speakers

THE advent of radio broadcasting raised the hope that the best music, lectures and addresses would be made available in our own homes. The hope was partially fulfilled by the development of powerful receiving sets that would bring in broadcasts from near and far. Listeners who were satisfied to wear phones were able to secure fairly satisfactory results, but the demand for a loud speaker that would make it possible for hearers to move about and continue their work while listening, and for numbers of persons to hear the broadcasts at the same time without phones, has been insistent.

To meet this demand, loud speakers have been invented, produced and placed on the market by the scores. Optimistic advertising and more or less successful demonstrations have sold these to radio users. Too often, a sale has been followed by bitter complaints from the customer which have been met by alibis from the dealer.

Some of these alleged loud speakers would be jokes, were it not for the disastrous effect they have on the radio business. Some of them have turned conservative, substantial customers, of high purchasing power, against radio so strongly that it will be years before their patronage can be regained. Even in front of some radio stores are loud speakers, placed there for the purpose of attracting customers, that assault the ear with a torrent of sound in which neither words, harmony nor melody can be distinguished. They kill more business in a day than advertising can bring in a month.

A few days ago I walked into a restaurant on Broadway, in New York. An orchestra was playing. The air

As
told
By
Armstrong
Perry

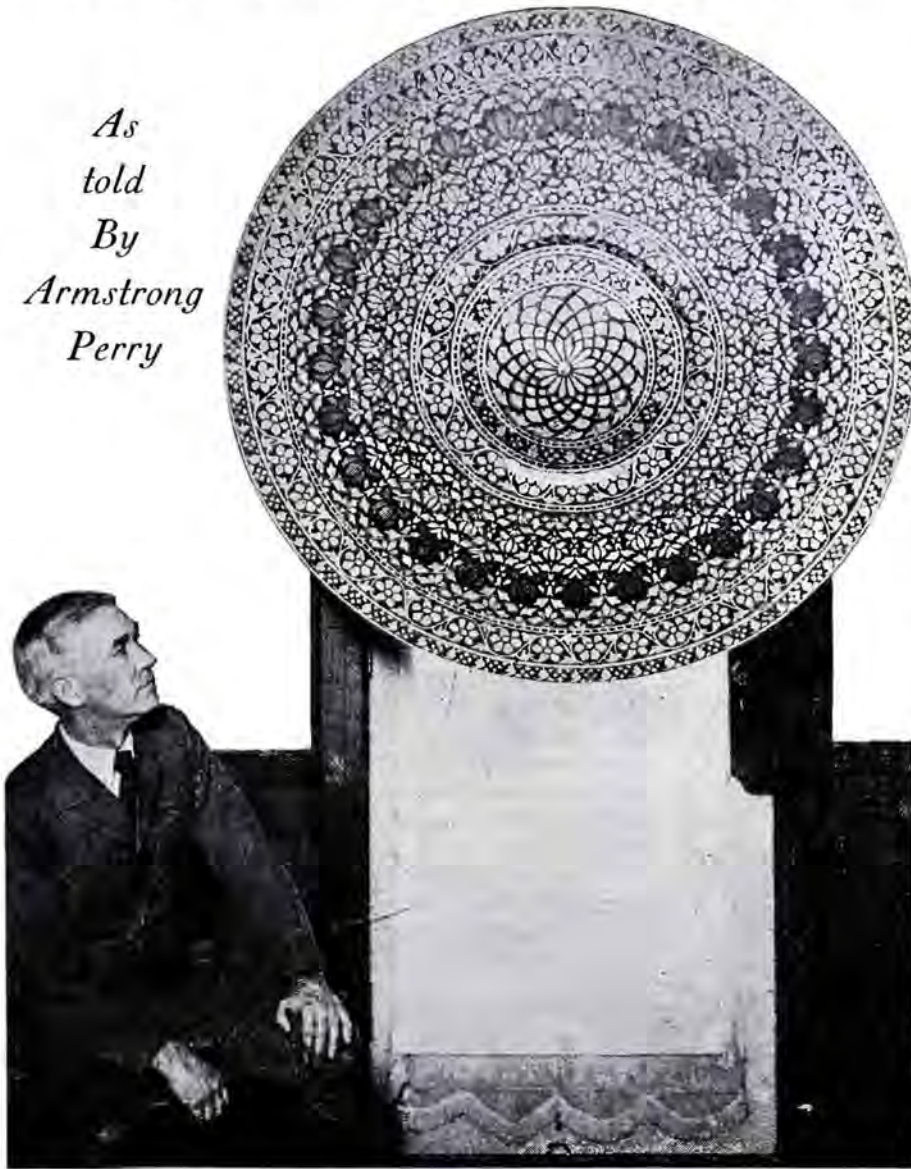

Armstrong Perry, the author of this article, is pictured below listening to one of the unique "Titanafram" speakers which so enthralled him in New York and which he believes is the only speaker yet developed that gives perfect reproduction of radio broadcasting.

was full of music interpreted with that reserve and expression that reveal the well trained and experienced artist. The orchestra seemed to be located on a balcony behind curtains.

So much impressed by the music that I wanted to see the musicians, I went up the steps to the balcony. No musicians were in sight. There were tables everywhere, and ladies whose visual beauty impressed the eye as satisfactorily as the beauty of the music did the ear.

In fact, there was no orchestra in the restaurant. The music was coming from a highly ornamental bronze shield hung from the ceiling. At first I was stumped, then I was so overcome by the situation that only strong self-control kept me from throwing my hat into the air and shouting "Hallelujah!" It was radio; honest to goodness radio. The reproduction was so absolutely perfect, in volume and quality, that when I turned my back to the loud speaker the illusion that the players must be in the room was strong again.

The announcer spoke. The voice was heavy and deep, but it was perfectly clear. The hiss of the "s," the elusive characteristics of the "f," the roll of the "r" and every tone and inflection of the voice was there.

Again the music. No matter how critically examined, it retained everything that even a trained ear could hear if the orchestra were in the room. The deepest note of the double bass, the highest treble of the violin when the player rests his little finger lightly on the

smallest string, were perfect.

These results challenged investigation. There was nothing to see from the front except the shield, about four feet in diameter, artistically decorated, suspended by a cord so small as to indicate that the device weighed only a few pounds. To prevent swinging, two similar cords, one on each side, served as guys. On the back, a frame straddled the central portion of the shield. Attached to the inside of it was a circular jacket three or four inches in diameter that evidently enclosed the mechanism, whatever it might be. A pin that issued from this connected with the centre of the shield. Two wires ran away circuitously to the balcony.

These wires led to a neutrodyne radio receiver. There may have been a power amplifier somewhere, but there was nothing to indicate that the radio equipment included anything that is not available to anyone in the open market.

More Than One Found

A SINGLE instance of efficiency is not entirely convincing. Another device of the same kind was found in a down town office, and a third in a private hotel in Brooklyn. All were delivering the same faultless results. The restaurant and the hotel reported that their radio music was attracting new customers daily and holding old ones. At the business office the constant inquiry was: "Where can outfits like these be purchased? How much do they cost?"

These questions were answered when the inventor was located. His name is M. C. Hopkins, and his headquarters are at the Hopkins Laboratories in Washington, D. C. He is the inventor of the cone type of loud speaker, though his claim to this distinction is being contested in the courts by some manufacturers while others are cheerfully paying royalties. It seems to be the old, old story. Somebody produced a new idea and made a better device. Then a lot of other fellows tried to steal the idea. Some of the imitators, by that peculiar mental process

which most of us can observe at work in our own minds, came to believe that they were the actual discoverers of the new principles. As is usual in such cases, the average observer can determine by comparison which device shows the work of the master hand.

It is a matter of record that Hopkins has been an expert in acoustics for many years, having designed many phonograph horns and other sound devices. The problem of the loud speaker claimed his attention in the earliest days of radio broadcasting and he has worked at it indefatigably every day since then. Even after he has licensed a manufacturer to use a loud-speaker patent, he sometimes has difficulty in preventing the adoption of "improvements," thought of by ambitious engineers, in which they repeat mistakes that he made years ago and corrected only at the cost of endless toil and expense. In handling radio and sound, the imitator has a hard road to travel unless he has a better foundation in science than most of them have. The real scientist is not likely to be an imitator because constant contact with truth makes him honest performer.

Mr. Hopkins stated that his new device, which he calls the Titanafam, is not for sale. No licenses are granted for its manufacture. He has nothing to sell but service. He will install it wherever it is needed, as rapidly as production can be developed. A per diem charge will be made which is a small fraction of the cost of maintaining an orchestra. Results will be guaranteed.

He will answer no questions concerning the mechanism of the Titanafam, nor permit anyone to examine it, because imitations, however crude, can be sold to the public and they hurt the good reputation of the original. He says that the Actuelle, a sound-reproducing device, which he invented, and which is applied to a phonograph, operates on a similar principle. From this he developed the cone type of radio loud speaker. The advantages gained in the latter have been carried further in the Titanafam, but this is not merely an overgrown cone.

His Last Effort

MR. HOPKINS' friends say that many of his devices, that seemed to them to be marketable, have been kept out of production through his habit of saying: "I can make something ten times as good as that." He says now that he has gone as far as he can go, and as far as anyone can go, in his opinion, in developing a radio loud speaker. Its reproduction of music and speech, he says, is practically perfect. I have heard testimony to the same effect from at least a hundred persons who, while listening to the device, were not conscious of my presence. The volume can be regulated so that it is substantially the same as that of an orchestra, or soloist, on the spot where their music is produced, or it can be made greater or less.

In the Brooklyn hotel, I stood beside the device while it was playing so loudly that the whole house was filled with music. The sound was so perfectly distributed that, with my ear to the Titanafam, there was no unpleasant loudness. The an-

nouncer sounded as though he were speaking into my ear confidentially, in an ordinary tone of voice. The music blended more perfectly than it does when the listener is in the room with an orchestra. That, the inventor explains, is because the players in an orchestra are necessarily placed on different spots and the ear makes the listener conscious of that fact, while in the case of the radio reproducer, the sound comes from a common source.

The possibilities opened by the new device are as limitless as the predictions at the birth of radio broadcasting. In some mysterious way the Titanafam filters out interference, or else, while bringing in local stations its great volume reduces static and other extraneous noises to such small percentages that the listener is unconscious that they exist. It actually brings the best music, lectures and addresses into places where the public may assemble, not in diminished volume, and with its finer qualities eliminated, but just as good as it is where it is produced.

HOW MANY LOUD SPEAKERS WILL DO THIS?

"In a Brooklyn Hotel," says Mr. Perry, "I stood beside this device while it was playing so loudly that the whole place was filled with music. The sound was so perfectly distributed that with my ear to the Titanafam, there was no unpleasant loudness. The music blended more perfectly than it does when the listener is in the room with an orchestra. It actually brings broadcast programs into places where the public may assemble, not in diminished volume and with its finer qualities eliminated, but just as good as it is where it is produced."



A progressive Illinois Farmers' bank uses radio to good advantage in giving out crop and weather reports for the farmers who bank with them.

The WEATHER REPORT

By
S. R. WINTERS

*A Gossipy Subject
Enhanced by RADIO*

A FARMER in Wisconsin upon receiving, by radio, a forecast of a cold wave of some duration communicated with his neighbors and secured their cooperation to the end of scraping and patching the community highway. The road was cut up and was in a pliable state until the pick and shovel were applied, a condition that would have remained so during the winter months had the cold wave settled upon it. However, the weather warning by radio enabled the farmers to scrape the bumpy highway and roll a new roadbed in the

nick of time. The cold wave, true to the forecast, arrived and the road with its fresh surface froze over. In a measure, it was a boulevard throughout the winter months.

A highway engineer at Carrollton, Illinois, was building a concrete bridge in sections upon the strength of daily weather forecasts received by radio at the local bank, duplicate copies of the bulletins being regularly supplied this bridge builder. A warning of rain may have necessitated the employment of an extra force in order to



Receiving Weather Bureau forecasts and fire warning signals at Howe Ranger Station, Wind River Columbia National Forest, Washington. Special attention is paid to wind forecasts to aid in fire prevention.



hurry to completion a section of the bridge. He was thus enabled to safe-guard his concrete building activities against freezing conditions.

A fisherman of Trenton, New Jersey, casts his nets and seines for the finny tribe in obedience to the storm warnings issued by radio. He writes, "I am interested in the weather prevailing and predicted on the fishing grounds from South Jersey as far north as New England." For a reason not altogether dissimilar, farmers in the vicinity of Peekskill, New York, realize the opportune time for harvesting of hay, lest rainfall spoil the newly cured grass. Likewise, producers of cranberries in the vicinity of Chatsworth, New Jersey, learn of the visitations of Jack Frost by radio. These frost warnings likely insure an adequate supply of cranberry sauce for your Thanksgiving and Christmas turkey.

Ranches Use Radio

Herdsmen on the ranches in Wyoming are safeguarding their shorn flocks of sheep and their offspring from freezing rains by virtue of weather forecasts dispersed by radio. The shearing of sheep and the arrival of new-born lambs are practically simultaneous occurrences and a wintry rain is disastrous to both unless shelter is given during unfavorable weather conditions. Warnings of precipitation, by radio, afford opportunity for the bringing of the flocks from the open range to the corrals, thus lessening the mortality rate of wool-and-mutton-producing animals.

"Fair and warmer; gentle winds," as commonplace as this phrase and its variations may seem, is of universal appeal. The universal language centers about the weather conditions. The Wyoming ranchman who tends his flock of sheep with the changeable weather conditions constantly in mind and the street-car conductor who exchanges greetings in terms of "cold weather" and "a fine day" are both concerned in forecasts, whether the interest is based on useful application or idle curiosity. Hence, it is safe to assume that music, speech or whatnot, when dispersed by radio, does not challenge as wide-spread interest as the condition of the weather on the morrow. The composite interest in weather reports is reflected by the results of a recent survey in which it is computed that 553,000 persons in the United States directly receive forecasts

by use of radio receiving sets. This estimate does not take into account the practice of the operators of these radio outfits who distribute the information thus received by conventional telephone to their neighbors.

In my opinion radio offers greater potentialities for the advancement of meteorological science than any

other development within the past 20 years," are the words of E. B. Calvert, meteorologist in charge of the Forest Division of the Weather Bureau, United States Department of Agriculture, in appraising this medium of intelligence for both collecting observations and in the dispersing of forecasts. That radio will be employed eventually as a vehicle of studying weather conditions in remote areas, not now invaded by the cable and telegraph is im-

AN AVERAGE city dweller is not vitally concerned with the weather forecast broadcast daily from the chain of official stations throughout the United States and considers this service more or less of a waste of time and effort.

This article gives some of the reasons why it is being maintained, and helps to place a value on the service. Out of door occupations in rural communities have learned to depend on these forecasts in planning their daily activities.

plied in the following words of Mr. Calvert which he gave to me in the course of an interview:

"We must secure data as to conditions that are occurring in the inaccessible regions of the north and study them in relation to the weather sequences. We know much of the laws in relation to storms and anticyclones; about where they form, and the effect of the rotation of the earth on their motions. We know that conditions in one country today will move to another tomorrow, the next day, or perhaps a number of days later. We feel certain that conditions in and about the polar regions have a decided bearing on conditions of the inhabited regions to the southward.

Ship Service Dominant

The use of radio telegraphy in the collection of observations pertaining to the weather in areas not penetrated by land-line communication systems is problematical, of course. The application of radio telegraphy in assembling and reporting atmospheric conditions over expanses of water is, however, a reality—in fact, a daily occurrence. Reports from vessels plying the "seven seas" are received with almost the facility and dispatch that observations are made and exchanged by the land-observing stations of the Weather Bureau. Ships equipped with radio apparatus have been enlisted to take and forward two observations daily to the district forecast centers located at Washington and San Francisco. A nominal sum is paid for each observation by the Forecast Division of the Bureau of Weather which has complete charge of all forecasting in the United States.



Even the most remote ranger station need no longer be out of touch with current events and the rest of the world in general. Scene taken at Long Valley Ranger Station, Coconino National Forest, Arizona, shows one of the hardy rangers absorbing a radio program.

Broadcast Listeners Enlisted to Collect Data on Static and Fading in Nationwide Tests

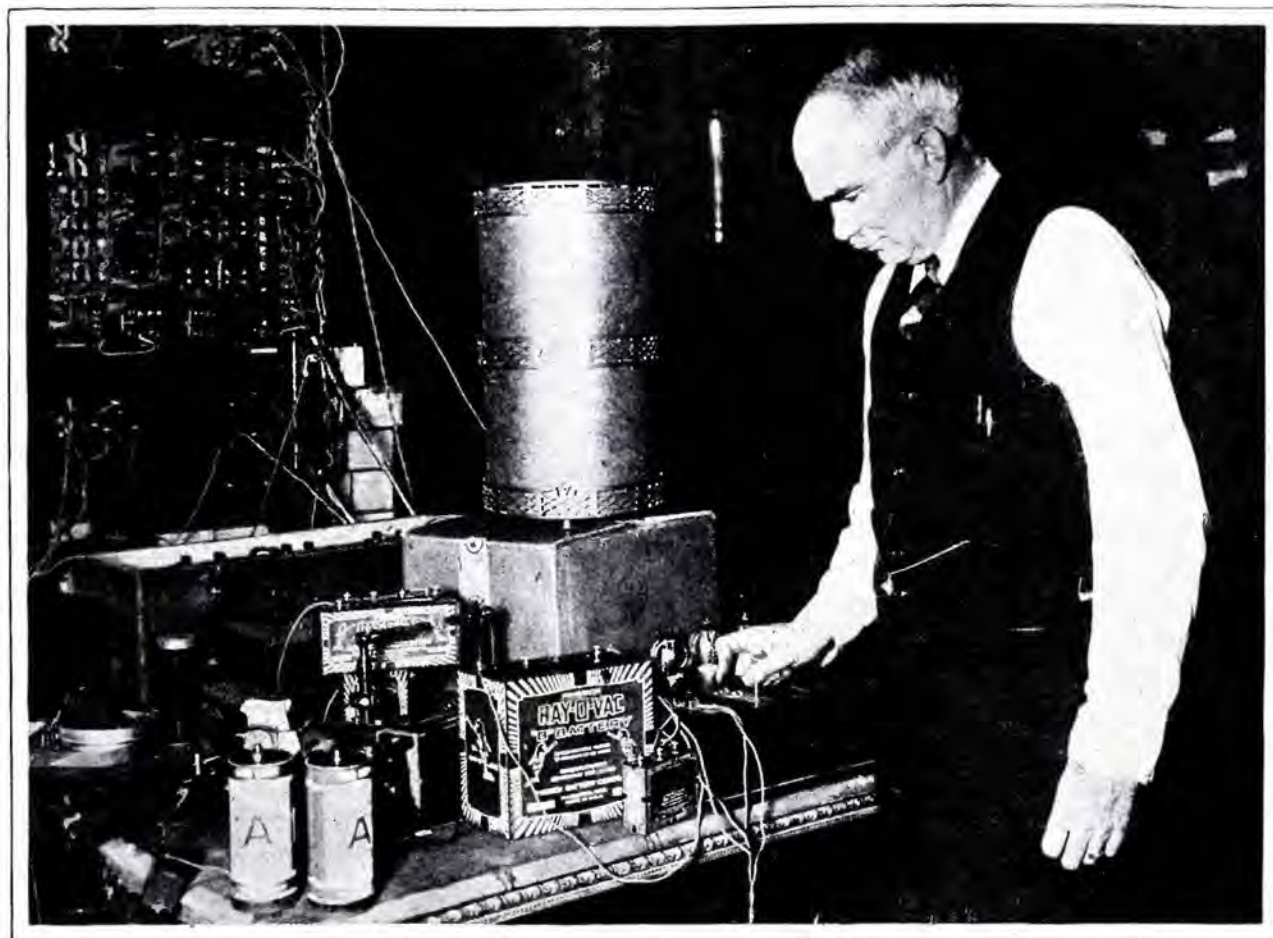

Dr. Lee De Forest is one of the outstanding scientists interested in this movement. He works tirelessly in his laboratory on inventions to make radio better.

Checking up on

ATMOSPHERICS and FADING

By GEORGE A. KING

ATMOSPHERIC blanketing, a radio annoyance generally classed as a symptom of fading, today, was given its own place in the list of wireless ailments and charted for further clinical investigation.

Members of the Northwestern University Department of Physics and engineers of the Stewart-Warner Speedometer Corporation, who are jointly conducting an investigation of atmospheric conditions affecting radio reception, announced the results of preliminary observations which are to be used in the national tests of static and fading.

This season has presented a number of phenomena which are



J. K. Smith, chief engineer of the radio department of the Stewart-Warner Speedometer Corporation, is in charge of this great fight against static. The data collected is being compiled under his direction for research at the Northwestern University Department of Physics.

very interesting as well as contradictory. The Monday night after Christmas was clear and cold—a night of the type which hitherto has been looked upon as ideal for radio reception. But despite a complete absence of dampness and heat, few stations were heard and such signals as were registered showed a serious diminution of volume.

It was the experience of observers at various points in the country that fading, generally associated in the public mind with "bad nights" for radio, was so slight as to be negligible.

Station WSB, which reaches Chicago with considerable variation in volume, was almost con-

stant. There was little or no fading of WGY or WBZ, where it had been expected, nor, for that matter, from any of the eastern stations. On the other hand, Omaha, which is well received in Northern Illinois even in summer time, was very erratic.

"Dead" nights are a common affliction throughout the United States, according to reports from observers assigned to make preliminary surveys for the National Static and Fading Tests. The nature of the atmospheric disturbance, or whatever it is that causes radio isolation of certain points has not yet been determined, largely because of lack of sufficient data on these phenomena.

Such dead spots are seldom stationary. They have been reported in Florida, the Middle West and Alaska and save for the fact that they are independent of conditions that cause static, little is known about them.

Reports just issued by the United States bureau of standards, analyzing the results of tests conducted by eastern stations tend to show that "super power" in broadcasting stations has only slight effect in overcoming radio reception difficulties, and at the same time increase in the sensitivity of receiving sets cannot remove the blanket which prevents broadcast signals from reaching the listener.

"Blanketing," its effect and its possible causes, will be tabulated for comparison with other atmospheric disturbances after the national tests.

Moonlight, a commodity general-

ly believed to worry nobody but the writers of popular songs, was revealed in a new role as a radio wrecker.

Published reports of private inquires into the causes of disturbances that prevent good radio reception so far have dealt with the manner in which atmospheric conditions are changed by sun spots, comets and eclipses. Even the aurora borealis has been investigated, but it has seldom been suggested that the phases of the moon might have anything to do with the adenoial performance of distant sopranos.

R. C. Therrien, an electrical engineer, of Chicago, forwarded to J. K. Smith, director of the national tests, a report covering a period of eighteen months. He suggested that it be investigated during the February tests and possibly at other times during the year. Parts of his letter follow:

"Eighteen months ago I discovered quite accidentally that distance reception was almost impossible on a night when the moon was full and high in the sky. I thought of course, that this might be merely a coincidence, but I remembered the magnetic effect of the moon on the tides, and it occurred to me that such a visible electrical display ought to have a definite influence on the ionized stratum of atmosphere or whatever it is that carries on, defects or blocks radio waves. Each Silent Night I made careful note of reception conditions and lunar phases and gradually I built up the evidence to show that my supposi-

(Continued on page 62)



Does the moon affect radio reception? The National Fading Tests aim to furnish something definite with regard to radio reception and phases of the moon

Below is a reduced reproduction of the official recording chart used in the Fading Tests. Detailed reports on reception of various stations with notations for atmospheric conditions will furnish definite clues for future work on static and fading limitations of radio.

Report of John Smith Observer at Ispahola, Ia. Zone No. 2
 Listened to Station W X Y Z Distance 500 Miles Date Feb. 10, 1926

TIME	NATURE OF SIGNAL	QUALITY	RECEPTION COMPARED WITH AVERAGE	BEGAN STATIC	ENDED STATIC	BEGAN FADING	LOW POINT	ENDED FADING	REMARKS
8:00	Violin Solo	Clear	Average	None	None				Few Clouds, Few atmospheric noises.
8:05	Orches.	Loud Rough	Average	Continuous		8:06½	8:08	8:09½	
8:10	Sopr.	Loud Rough	Average	Continuous		8:12	8:14½	8:16	Irregular static crashes.
8:15	Sopr.	Poor	Below Average	Continuous		8:18	8:20	8:23	Signal lost at 8:20.
8:23	Sopr.	Loud	Below Average	None					Signal returned at 8:23.

ANTENNA of RECEIVER—(Check Type and Conditions in designated Columns)

Type	Location	Direction	Height	Length
Vertical	Open Country	E. - W.	"Lead in"	___ft. with
Horizontal	Among Trees.	N. E. - S. W.	End ___ft.	___ft. lead in.
Single Wire	Suburban.	N. - S.	Far end ___ft.	
Loop	Congested City.	N. W. - S. E.		
	On Apt. House.			
	Many Ant. Near			
	Iron mines ½ mi. East			
	On Hill.			
	Near steel structure			

Observations to be made at five minute intervals from 8:00 to 11:00 P.M. on each of above dates, Central Standard Time. Mail report promptly to J. K. Smith, Radio Fading Test, Stewart-Warner Speedometer Corporation, 1826 Diversey Parkway, Chicago, Illinois.

Radio Conquers the ARCTIC

By H. H.
ROEMER

**Zenith Expedition to
Far North Leaves
No Doubt of
Radio's
Value**



RADIO, to the more thickly populated and civilized parts of the country, is as commonly known as practically every other known device of entertainment and educational value. It is true that a far greater percentage of the radio public do not actually know the "why" of radio, other than it produces, conveys and brings into the home, the voice and music of thousands of miles away. We simply accept it because we hear it and we recognize the accomplishment.

Then there are those more remote people—on farms—out on the plains and in the hills and in the valleys—people who by reason of long distances to the larger towns in their communities, or because of impassable roads, find it impossible to come in contact with modern inventions of entertainment and they accept radio for what it does and from it they receive the incalculable benefits of entertainment, of education and of that financial good that grows out of information on, not alone weather conditions for the raising of their stock and produce, but on the market prices, which by radio, they have through instant contact with the markets of the big buying centers.

We must not pass by that great factor in the saving of human life and property that accompanies the sea-going craft and which, before the advent of radio, cost human endeavor the loss of many of the world's greatest men, women and money beyond the measure of words.

A New Sidelight on Radio

BUT in all this, comes a situation which is difficult for the city people, for the country folks and those living on the plains and in the hills and who are trav-

Radio May be Only Means of Educating Eskimos, Who Regard it as Miracle

—sing the seas to understand—the penetrating of the human voice and the music and the news of the day to those men who give unto civilization the findings of those unknown parts of the world, explored

by them, that we may know more of our world and the peoples with whom we never come in contact, and who, by the efforts of the explorer as in the entire history of this world, we gradually come into contact with and through the progress of civilization they are enlightened and advance as we have done.

But to the explorer radio bears a far more important work than the mere reception of entertainment and news. In listening to the explorers Commanders Donald MacMillan and E. F. McDonald, who returned recently from the MacMillan Arctic Expedition and who got as far as Etah, Greenland as their main base, many interesting events were told us, many that are difficult for we, of the civilized land, to understand.

In North Greenland, within eleven and one-half degrees of the North Pole, the Eskimo tribes live from year to year, with nothing behind them other than

those long months of night and day. For them, the same weapons of defense and the same means of mechanical construction still exists that held with us hundreds of years ago. Only through the far separated visits of these brave explorers does the Eskimo come in contact with modern developments. He is one of the smallest and most primitive individuals in the world. He hasn't had the advantages that slow educational progress affords, and when MacMillan and McDonald appeared in their midst last summer, they looked upon the flying machine as simply another "miracle of the white man."

They could not under-



The Eskimos discovered by the Zenith Expedition are the smallest and most undeveloped people on earth. They regarded radio as an inexplicable miracle brought by the white man, and would not believe it a tangible thing even when voices of their own tribesmen were broadcast. The photo shows a typical group on an island visited by Commander McDonald.

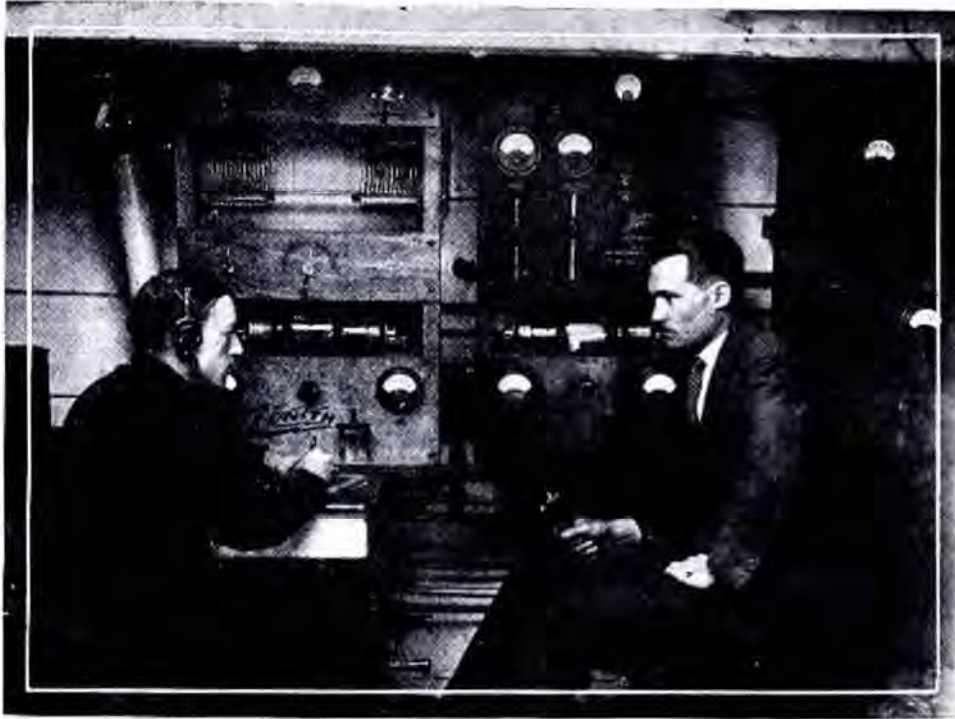

Radio Operators McGee and Gray of the S. S. Peary, which helped Commander McDonald to communicate daily with the Zenith offices in Chicago, are shown at the left before the powerful Zenith radio installation aboard the Peary. As McDonald predicted, daily communication was almost as easy as reaching for a telephone.

stand it. Their brains could not perceive the "why of it." They saw the planes perform and accepted it as a thing super-human. They listened to the radio and pronounced it a "miracle of the white man." They could see no difference between the phonograph and radio, even though at one point one group of Eskimos was placed at the microphone, and a few miles distant, another group was placed at a receiving set, and heard the voices of the first group in their native tongue, but they only shook their heads, admitting recognition of the voices, but simply accepting the "miracle."

Time will come when radio will be a part of their living equipment—the means of their education—in fact, practically the only means of that constant contact which is necessary to developing the human mind.

Missionaries Pave the Way

THE missionary will do his part and through radio; he too, will keep abreast of the times and his work will be a greater inspiration. I recall Commander McDonald stating that he dropped some twenty Zenith Receivers along the coast on their way to north Greenland; distributing them among the missionaries whose thanks and great appreciation are evidenced by the glowing letters received by McDonald since his return to the States. The missionary will learn the operation of the radio and through him, the Eskimo, as well as the other uncivilized peoples of the unexplored parts of the world, will learn the civilized way, and in time, through radio, civilization will reach all parts of the world.

It will be an interest-

ing revelation to the reader to know of certain conditions that existed during the absence of Commander McDonald from his business, as President of the Zenith Radio Corporation of Chicago. A day or two before his departure, there was a meeting of executive heads and he was asked if he had arranged with his associates so that they would understand everything he knew and wanted carried out in the business, and also whether

he had arranged his investments so that in the event of any change in the market we could protect his interests and act intelligently in his absence. Mr. McDonald replied in surprise, "Why I am not going to be any further away from you than your telephone." They sailed for the Arctic on the 17th of June and they were not out three nights when the Zenith Arctic Experimental Station 9 X N (at Arlington Heights, Illinois,) and which was in direct telephone connection with the Zenith Executive Offices in the Straus Building, Chicago, began to receive messages from the S. S. Perry, of which Mr. McDonald was in command, and this continued throughout the days and nights of their entire journey both to and from Greenland.

On one occasion, there was an executive meeting at Zenith headquarters, discussing a certain issue of great importance, when it was decided that two of its officers would make a hasty trip south. The question arose, "Mr. McDonald handled this deal originally and it may be that he has certain information which would

change the situation materially." Then the committee feared they could not get the information back in time to make the train these officers were scheduled to leave on and which allowed only three hours.

The treasurer took down the telephone receiver and called 9 X N at Arlington Heights, requesting McDonald at W A P which are the call letters of the S. S. Peary then lying in the harbor of Etah, Greenland, eleven and one half degrees from the North Pole. He held the receiver while the operator at 9 X N sent

(Turn to page 49)



Commander Eugene F. McDonald of the S. S. Peary getting chummy with a group of Eskimos near the anchoring spot of the expedition's ship. Needless to say, the Eskimos have been modernized sufficiently to learn to inhale American-made cigarets.

*How the Intriguing
Dot-and-Dash Hobby
Holds its Devotees
With the Thrill of
DX Conversations*

Q This contraption is a simple amateur sending set that has been heard at the very corners of the earth. It employs an ordinary UX 210 power amplifier for an oscillator, and consumes less energy than an ordinary electric light bulb. With it Burton Synott has talked to nearly every civilized foreign country in the world.

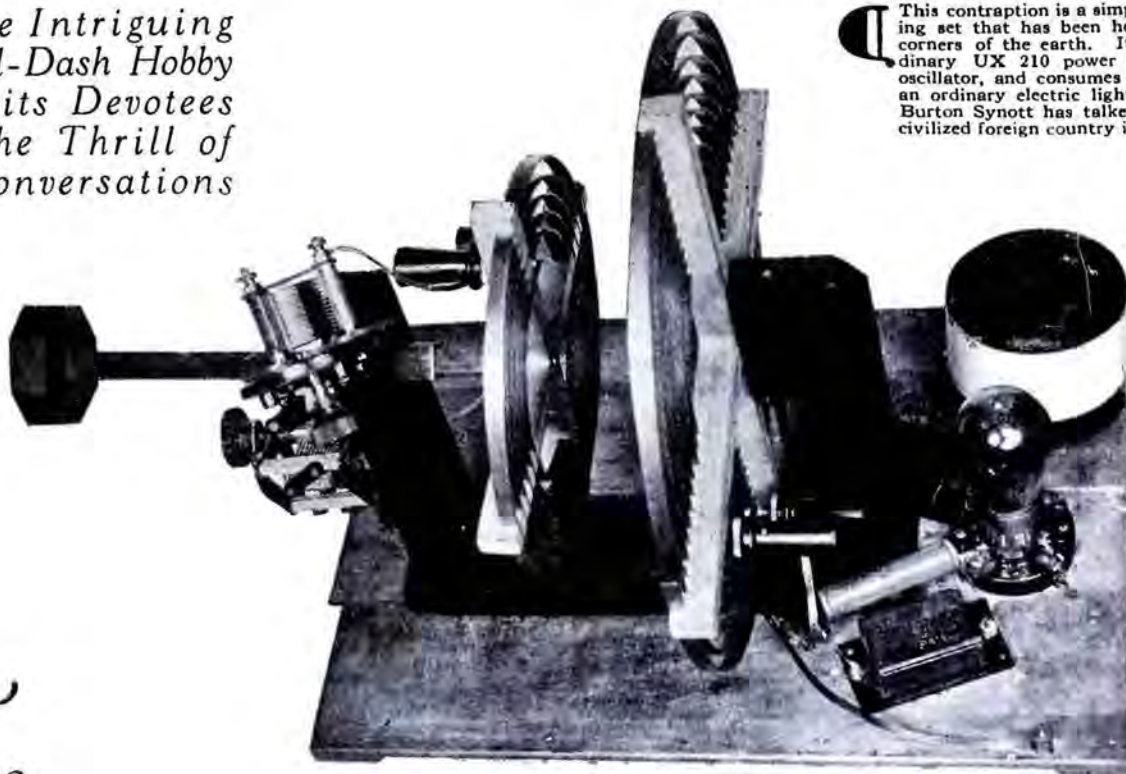

The

WORLD at your FINGERTIPS

Distance Lends Enchantment
In Amateur Code Transmission

says

BURTON SYNOTT

Radio 2BBX

THE QUESTION uppermost in the minds of most people who have had an opportunity of visiting and inspecting an amateur radio station is usually "What entertainment or personal gain can be realized from this hobby?"

Being an amateur for the past ten years and having a wide circle of acquaintances in the amateur radio fraternity, I believe I can explain just what "ham" or amateur radio holds in store for its devotees by recounting some interesting and enlivening experiences which I have had in connection with the operation of my amateur radio station 2BBX.

Transmits With Small Power Tube

To begin with, this station is not a "super power" station or an "ether buster." This is due to the fact that the power which is available for the transmitter is limited. Consequently, the tube which is used in the transmitter is only an ordinary power amplifier tube. This tube is a standard UX210 and can be seen hiding behind one of the inductances of the transmitter which is on the shelf above the operating table. All this can be seen in the photograph and it will be noticed that there are not many loose wires trailing around the room, as such condition would detract from the appearance and efficiency of the station as a whole. Incidentally, it may be of interest to note that this little station is one of the lowest powered radio stations in existence, as the power input has at all times been well

below 25 watts. Considering the results and the distances which have been consistently covered, this power (which is only about one twentieth the power consumed by an electric household iron) seems ridiculously low.

The stick, hanging down from the shelf is not used for self defense against angry broadcast listeners, but serves as a handle for the switch which controls the power supply and transfers the aerial from the receiver to the transmitter or vice-versa.

On the operating table are two receivers, one of which covers the wave band between 15 and 50 meters and the other the band between 90 and 600 meters. A good, accurate wave meter is also kept handy and is a very great help in tuning and checking wave lengths.

Recounting Some Experiences

CCAREFUL observation will reveal a crack in the marble top of the operating table, midway between the two receivers and in thinking of this, I unconsciously rub a certain spot on my head and recall a certain night in April of last year.

It was midnight and outside the elements were raising a terrible ruction. I could not seem to "raise" any other stations and the static was fierce. To while away the time, I decided to tinker around a little. I left the phones on my head and the receiver tuned to about 150 meters and stepped up on top of the table and commenced to "fiddle" around with the trans-

mitter. While engaged in this (the "Royal Sport of Amateurs") my attention was drawn to a faint, peculiar signal, which seemed to challenge my ability to decipher it. I stopped and still standing on the table, managed to make out the call letters "NITC." I immediately realized that this call belonged to a government ship station.

The operator was evidently trying to get in touch with some station, as he was using the signal "CQ," which means that any station hearing him was invited to communicate with "NITC." Just as soon as I succeeded in reading him, he signed and all was silent. I was so surprised to hear him and so anxious to answer his call that I temporarily forgot my precarious situation on top of the table. I made one mad clutch for the switch handle, but missed. The next thing I knew, I was sailing through the air, and in obedience to the law of Ike Newton, downward to the floor. As luck would have it, however, my head collided with the marble table top and due to the extreme softness of the same it simply cracked. All this, of course, had nothing to do with working "NITC" which was the subject in which I was most interested at the time.

Answers DX Call

SHAKING my head to stop the room from spinning around I commenced to call "NITC." As I clicked the key, I turned the pages of my call book and discovered that "NITC" was the United States Coast Guard Cutter "Tampa." I called him for about three minutes and then threw my change-over switch to the receiving side. Imagine my surprise, when I heard him actually answering me! He informed me that his ship was on ice patrol duty and was at that time about 500 miles off the Newfoundland Coast. I was also informed by him that I was the only station who had answered his signals and that he was anxious to get some very important messages through to Washington through my station if I would care to relay them for him. I took five messages for him, one of which was to the commander's wife, and then we said "Good night" and signed off.

My trouble was amply repaid by a letter I received a few days later from the Coast Guard Commandant at Washington, in which he thanked me for the service I rendered him. In addition to this, I was pleasantly surprised to receive a copy of the Coast Guard Manual, in which mention was made of this incident.

Signals Heard in Africa

It is considered very difficult to cover any great distance using the longer amateur wave lengths, or from 150 to 200 meters with low power input. This belief was severely knocked in the head, when the postman met me and handed me a letter

with a strange stamp on it. Upon opening it up, I nearly required the attention of a doctor for I read that my signals had been heard at Cape Province, South Africa, by station "O-S1D," owned and operated by a Mr. Faull. In his highly appreciated letter, Mr. Faull stated that he was using only two tubes in his receiving set at the time he heard my station.

This, to the best of my knowledge, constitutes a world's record considering the distance covered and the fact that the power used was only twenty-two watts.

Then came this short wave "business," which has practically taken the entire amateur world by storm. In order to determine what advantages, if any, were afforded by the use of short waves, I decided to give them a trial at my station. The latter part of June, 1925, with static at its worst, found me experimenting with my low powered set on 39.7 meters. The results, using this wave, have been so satisfactory and the work done so superior to that accomplished on the higher wave, that it has been definitely decided to maintain this wave for all traffic and message handling.

Here's a Real Thrill

THE first thrill I received on the low waves, came on July 1st, 1925. As usual, the static was hammering in louder than most of the signals in true mid-summer style. I was sending out the old and popular "CQ" signal and endeavoring to raise some station with whom I could "chew the sock." I "CQ'd" for about two minutes and then threw the antenna switch to the receiving side and started to turn the dial on my receiver rather idly, as I did not particularly care if I got any answer or not, and on account of "Baby Ben" telling me that it was two a. m. I was not destined to go to bed early this time. I heard some station calling me and then he signed. It was "Z-4AR" at Dunedin, New Zealand!! Just imagine, nearly half way around the world on twenty-two watts! Needless to say, the whole household was awakened on this "glad" occasion. Many were the remarks which were made by the various members of the family and a great deal of diplomacy was required in order to be allowed to stay at the set long enough to exchange greetings with my distant "brother ham." Good communication was effected for about twenty minutes and when we finally signed off it was only due to the fact that we had no more things to talk about.

This thrill of working the Antipodes, which I enjoyed, wore off gradually and so did my vigils in the wee small hours. You will undoubtedly agree with me that these all night vigils are very hard on one's constitution.

So real "DX" was sacrificed, temporarily at least, when I
(Turn to page 52)



THE RECEIVER
AT 2BBX

Would you believe that this receiver is capable of hearing the opposite side of the earth? NO? Neither would we until we saw the confirmation cards received by the owner, Burton Synott, a Bronx amateur.

most of the signals in true mid-summer style. I was sending out the old and popular "CQ" signal and endeavoring to raise some station with whom I could "chew the sock." I "CQ'd" for about two minutes and then threw the antenna switch to the receiving side and started to turn the dial on my receiver rather idly, as I did not particularly care if I got any answer or not, and on account of "Baby Ben" telling me that it was two a. m. I was not destined to go to bed early this time. I heard some station calling me and then he signed. It was "Z-4AR" at Dunedin, New Zealand!! Just imagine, nearly half way around the world on twenty-two watts! Needless to say, the whole household was awakened on this "glad" occasion. Many were the remarks which were made by the various members of the family and a great deal of diplomacy was required in order to be allowed to stay at the set long enough to exchange greetings with my distant "brother ham." Good communication was effected for about twenty minutes and when we finally signed off it was only due to the fact that we had no more things to talk about.

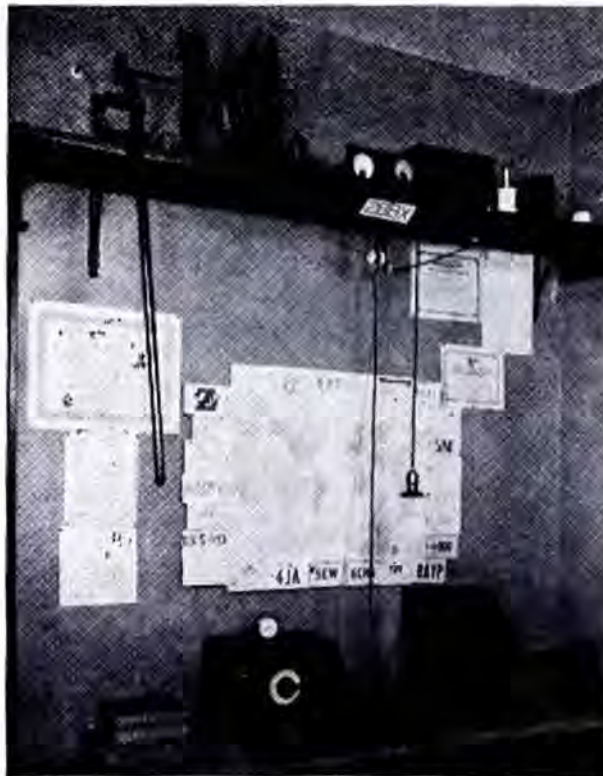

VISITING A MODEL AMATEUR DX STATION

The accompanying story narrates some of the thrilling and exciting experiences an amateur broadcaster has in the course of operating his own station. The photo shows the neatness and efficiency characterized in the station of this unusual recount of amazing experiences.

Milwaukee Goes in for Radio

By JOHN M. RIDELL

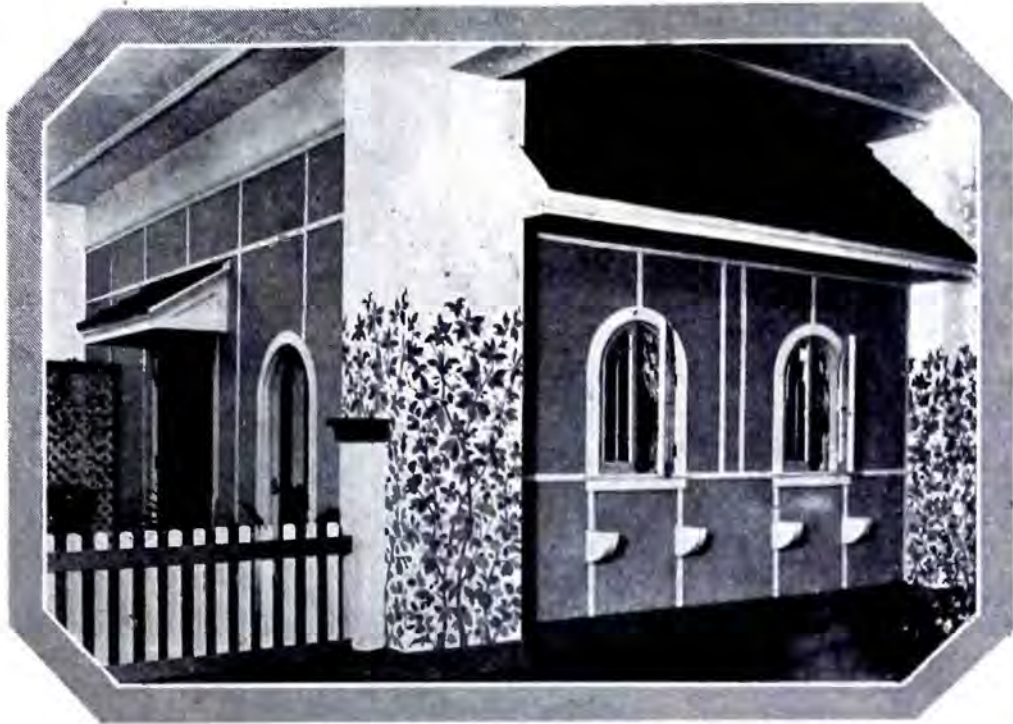

THE studio of WKAF at Milwaukee, Wis., is one of the most unique in the country. It is housed in the beautiful bungalow pictured above, in the Hotel Antlers, and the layout of the interior, as well as the exterior shown above, may be said to be about the most unique yet devised. An air of "Make yourself at home" pervades the entire studio atmosphere.

Entire "Cream City" Gets Behind Station WKAF; Now It Ranks with Best

LAST FALL, Milwaukee was agreeably surprised by the opening of a new station—WKAF—known as the Kesselman-O'Driscoll-Hotel Antlers Station on the Hotel Antlers.

It went on the air at 10:30 at night and remained on until 12 o'clock midnight, with a program of such exceptional merit that no end of comment has been received at the Station's office regarding it. The station is tuned as sharp as a razor blade and has a tone quality equalled by few stations in the country. Distant points on the Atlantic and Pacific Coasts, Canada, and southern states were easily reached, although the Station was operating on only one-fourth of its power.

The program was opened with an address by the Managing Director, Phil A. Grau, who was formerly Executive Director of the Milwaukee Association of Commerce, is a member of the bar, and was secured by the owners of the Station because of their desire to bring into the radio field men of the highest caliber in the business and professional world. Mr. Grau's opening address was as follows:

“THIS is Station WKAF, broadcasting its opening program on 261 meters. It is known as the Kesselman-O'Driscoll-Hotel Antlers Station on the Hotel Antlers, Milwaukee.

“Believing that the future of radio depends upon

PICTURES BY THE AUTHOR

better and better programs, tone quality, and volume, as well as distance, those who have erected this Station will endeavor to give you entertainment of such a character that you may always look forward to it with pleasure.

“They have made it a commercial station, which means—if you are not familiar with the term,—a station whose time in the air, or 'on the air,' if you wish, may be engaged for a definite consideration. The advertising value of radio is such that many large advertisers have already recognized it through the excellent programs being broadcast under their auspices by many stations in the United States. This enables radio broadcasting stations to give to you listeners the services of excellent artists and programs of high character. It solves the problem of who is to pay for broadcasting. For we in this country do not believe as they do abroad that the 'listener in' should be called upon to directly share the expense.

“Therefore this station frankly admits, as does WHT of the Wrigley Building, Chicago, and other stations of a commercial nature, that its time may be engaged. It makes no apology for entering the field in this manner because it presents to the public the newest type of high-class advertising media, one that goes directly into the home and entertains while it calls to mind the products in behalf of which it is putting forth its efforts.

"Our program tonight is, of course, our *own* opening program, offered by the Station itself. It is not an elaborate one. On the contrary, it is a simple one. But we believe you will find its quality of such a character that you will agree in our decision not to have advertised it with a flare of trumpets and a shower of verbal pyrotechnics. If we please you we shall be delighted to hear from you. If you have any constructive suggestions to make we will gladly receive them. You may address us care of the Hotel Antlers, Milwaukee, Wisconsin.

"In behalf of Messrs. Wood, Kesselman, O'Driscoll and Ford, the owners of this new super-powered broadcasting station, I now present to you Mr. Robert F. Hall, our Studio Director and Announcer who will now announce this evening's numbers. We hope you will enjoy them and send you greetings of good will from Station WKAF, Milwaukee."

The Studio Director and Announcer is Robert F. Hall. Mrs. Hall (Anita De Witt Hall) is the Studio Hostess and Accompanist. Mr. and Mrs. Hall have spent nine years on the Keith Circuit. Mr. Hall played leading man in Fiske O'Hara's "Marry in Haste", Mrs. Hall being accompanist and orchestra leader. Mr. Hall's voice and Mrs. Hall's work on the piano have already won numerous very favorable comments from "listeners-in" and will continue to be part of the regular programs.

H. O. Wood at Head

HIRAM O. WOOD, one of the owners of the Station, is the proprietor of the Hotel Antlers. He is a well-known hotel man and, in keeping with his belief that his guests in his hotels deserve the best there is for their money, he has made every effort so far as the Station is concerned to construct on the Hotel Antlers a Station second to none in the country.

L. M. Kesselman, also one of the owners of the Station, is the senior member of the firm of Kesselman-O'Driscoll Company, a well known music house of Milwaukee. His interest in broadcasting dates back several years when the Kesselman-O'Driscoll Company operated its own broadcasting station which was afterwards turned over to the Milwaukee Civic Broadcasting Association as a civic venture. This station, however, has now been discontinued.

The Station was constructed by Howard L. Ford, its Engineer, who is also one of the owners of the company owning and operating it.

The transmitting equipment used by Station WKAF is all of special design which is a radical departure from common broadcasting engineering practise.

The entire transmitter, including the 5,000 watt water-cooled power tubes, the oscillatory circuit, and the power amplifiers, is enclosed in a steel cabinet, each division of the equipment being entirely shielded from the other.

The power supply for the transmitter, including both high and low voltages, is delivered by Willard Storage



***M**ISS JEAN HAMMOND, one of America's most talented musicians. She is conductor of the Jean Hammond Orchestra, composed entirely of young women, who broadcast regularly thru WKAF from the dining room of the Hotel Antlers, Milwaukee. Each musician is an expert in her chosen line of music, playing jazz and the classics with equal dexterity.*

Batteries, insuring absolute freedom from noise in transmission and uninterrupted operation.

The giant water-cooled tubes are supplied with water from the city main, through a specially devised system of insulating the water column.

The microphone system and input amplifiers are so designed as to permit the use of any number of microphones or remote control systems and have a frequency characteristic enabling them to handle with equal facility all of the notes used in even unusual conditions of broadcasting.

The antennae of the station, which is supported by a 165 foot cement smoke-stack is unusual in appearance and design, consisting of a parabola cage separated fifteen feet between wires. This antenna is used with a direct connection to ground, without the use of the usual counterpoise, and is fed from the transmitter by three tuned oscillatory circuits and a system of harmonic filters which insure the radiated energy being free from all disturbances and enables the use of high powers without disturbing influences from nearby receiving sets.

The regular hours for the studio programs are Sunday afternoons from 4 to 6, Monday, Wednesday and Friday nights from 10 to 11.

BBROADCASTING officials have concocted psychological remedies which are guaranteed to glue public speakers before the microphone during an address and otherwise cure pernicious pacing and wandering about the lecture platform.

Credit for this unique discovery—called "the magic rug remedy"—goes to technical staff members at KOA, Denver broadcasting station of the General Electric Company. First an-

nouncement of the cure was made today following a ten-month trial involving the worst offenders among national and western speakers who have appeared before radio listeners.

"Not once has our magic device failed to turn the trick," asserted Alfred Thomas, resident engineer in charge of technical operations. "Most any type of rug fills the bill if it is soft and of contrasting color with the floor. It should however, be of small dimensions, say three or four feet. It is placed a few feet from the microphone, the distance depending wholly upon the voice of the person to be heard.

"Unconsciously, the speaker assumes a position on this rug before the microphone and there remains until his remarks are concluded. Subconsciously, he regards this piece of floor-covering, with its imaginary boundaries, as an island of safety and is disinclined to venture elsewhere about the stage. As a result, broadcast listeners are enabled to hear the talk in full. Otherwise, some of the speakers' comments would be lost to the invisible audience.

"The plan to prevent a speaker from taking gymnastic exercise on the lecture platform is indeed novel," declared Dr. D. E. Phillips, eminent psychologist of the University of Denver.



The Brains Behind Your Radio Set

Men who are responsible for the enjoyment you get out of your radio set. Left to right, front row: Frank Conrad, Donald McNicol, Dr. J. H. Dellinger, Dr. A. N. Goldsmith, R. H. Marriott, E. F. W. Alexander, W. H. Hubley, J. V. L. Logan, C. W. Horne, L. Espenschied, A. H. Grebe, Prof. J. H. Morecroft, Melville Eastham, Greenleaf Pickard and L. E. Whittemore. At right—Prince Wilhelm, Sweden's poet Prince, reading some of his verse into the microphone.



In "Radio Alley"—Cortlandt Street Is Mecca of New York's Radio Fans

Cortlandt Street, N. Y. is "Radio Alley." On either side of the thoroughfare radio stores abound and when the radio fan wants anything in the line, from a simple screw to an elaborate console set, he knows he can find it in one of the shops on the street.

Kadel & Herbert Photos.

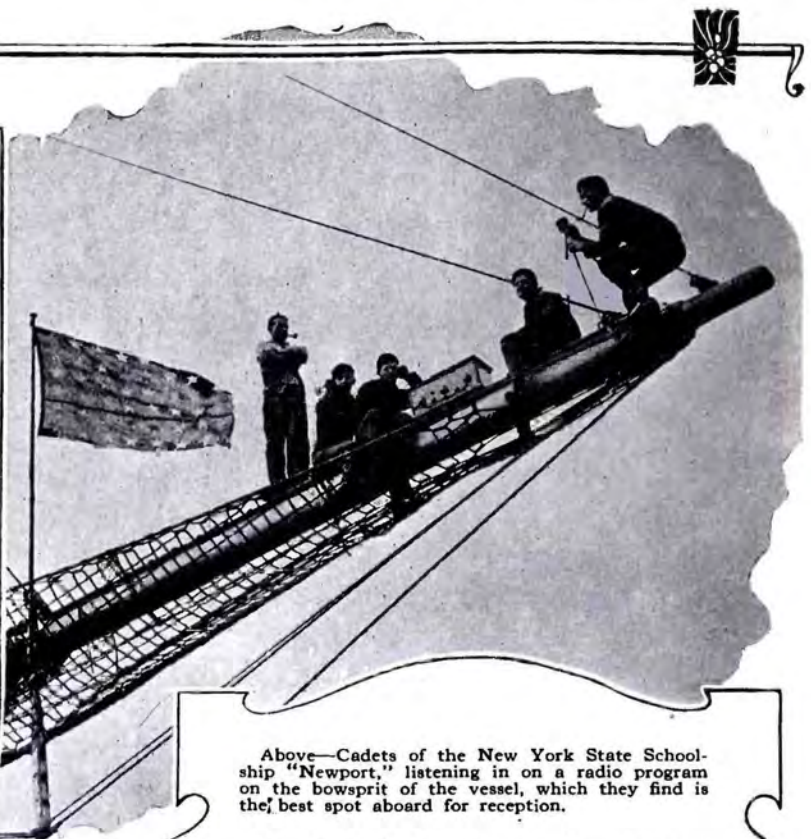

Above—Cadets of the New York State Schoolship "Newport," listening in on a radio program on the bowsprit of the vessel, which they find is the best spot aboard for reception.

At left—Radio Interviews are becoming very popular with the broadcast directors. The photo shows Morris Gest, theatrical impresario as he appeared when interviewed over WLW recently.

Kadel & Herbert Photos



The first radio play, "Sue 'em," winner of a contest conducted by station "WGBS," New York, was put on the air on December 29 by three stations, "WGBS," New York; "WIP," Philadelphia, and "WGY," Schenectady, by members of the Provincetown Players. The play, the first radio production ever presented over the air, was a complete success, judging by the applause cards which the broadcasting stations are receiving from their listeners





London has discovered the latest radio possibility—"Phantom Dancing." The "light fantastic" is "tripped" to the strains of radio music, heard thru head phones by the dancers, but inaudible to spectators.

Boston Radio Fan Constructs the Smallest Eight-tube Super-Heterodyne—All Self Contained.

At right—Boston radio fan, A. S. Moffat, has constructed what is believed to be the world's smallest and most compact eight-tube super-heterodyne radio set. A cabinet, 18 inches long, 13 inches wide and 6 inches high, contains the complete set, including loop, batteries and loud speaker. It is a complete unit for traveling purposes and can be used equally well in the backwoods or hotel room.



Circus freaks are normal radio fans. That is, if a radio fan can ever be said to be normal. These odd folk, upon whom nature has played varied pranks, have a radio set with them on their travels and delight in listening in, whenever they can. Here is group around the set; Jean Libbera, The Man With the Two Bodies; Saleem, the Dervish Rajah; Baron Paucci, Smallest Midget, is seen tuning in; Cliko, The Bushman; Syed, The Egyptian who knows more about you than you know about yourself; and, finally, Ajax, an honest-to-goodness sword swallower.

Kadel & Herbert Photos

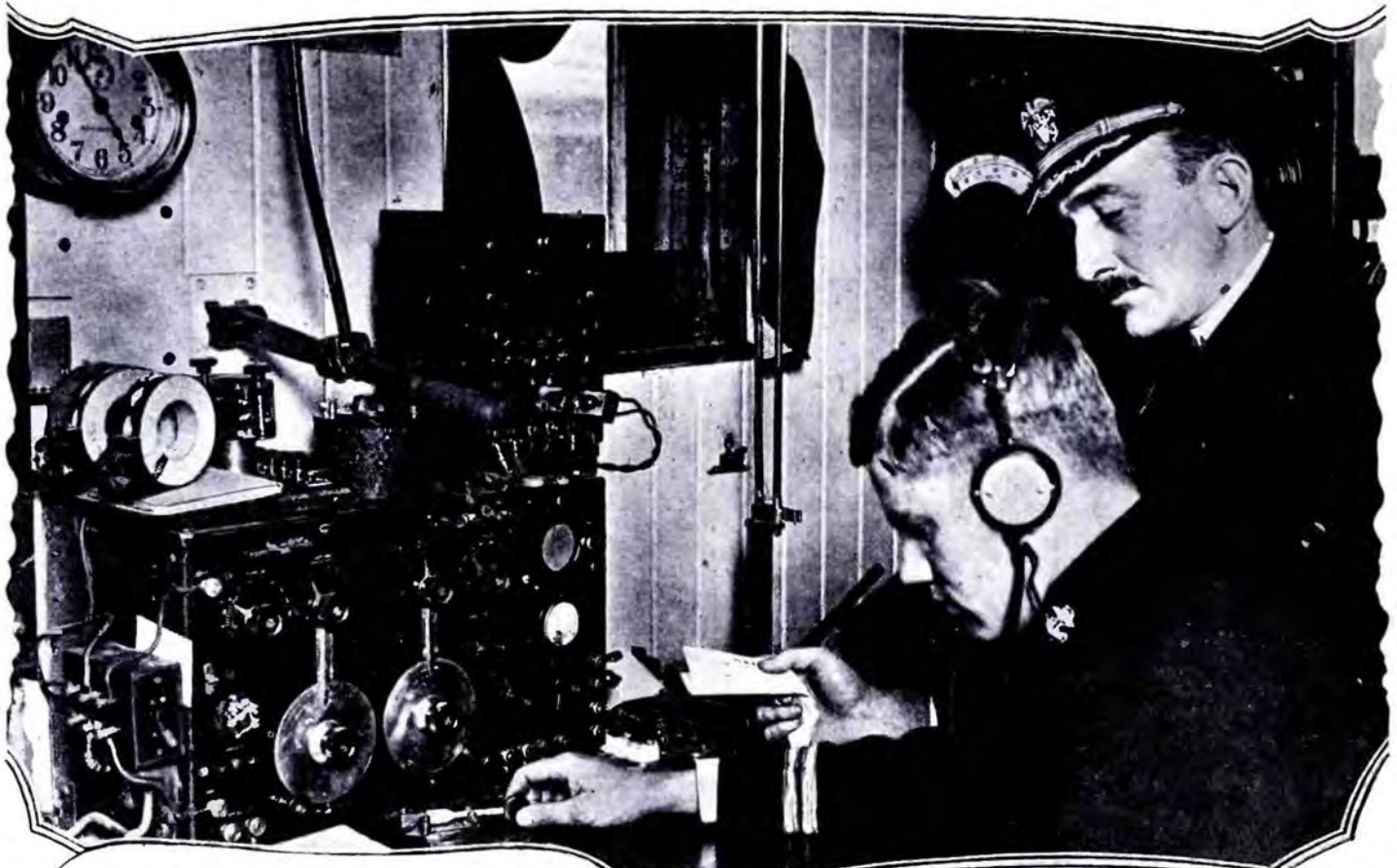

How often, in the midst of a good radio program, have you heard the cryptic "Signing off, account of an S. O. S." and then silence? Every broadcasting station has a receiving set, constantly tuned to 600 meters, to catch S. O. S. signals, and in most stations, a man sits at that set with headphones always adjusted, ready to stop broadcasting when a distress signal is received. When the sea danger signal and cry for help is being sounded, it is necessary that all broadcasting cease to obviate interference with the emergency call. The photograph illustrates the wireless room of the S. S. Southern Cross, and the captain of the vessel giving a message to the radio operator.



Above—Dr. John H. Dellinger presenting prize, a check for \$500.00, to Frank Conrad for his work in the development of the short wave in 1925, which was the outstanding radio achievement of the year.

Alois and Mitzi Vashek, two midgets from Hungary, giving a program thru the microphone of station "KHJ," Los Angeles. Both are accomplished musicians and have the distinction of being the smallest full-size folk who ever sent out a message "over the air."

DEFINITE steps are now being taken by the Radio Manufacturers' Association to standardize all radio parts where possible, so that different brands will be interchangeable. A great deal has already been accomplished. It was only a few months ago that the buyer of a jack and a plug had to fit them together in the store to be sure that they would make a connection.

Other industries have taken many years to accomplish standardization of parts, but A. J. Carter, chairman of the standards committee of the Radio Manufacturers' Association, believes that this new industry can reach the same goal in a short time.

"The radio industry has grown so rapidly," said Mr. Carter, "that everybody has been busy making, jobbing and selling radio equipment and has had little or no time to give attention to conforming to any certain sizes or dimensions in the manufacture of the various parts.

Irregularity of Parts

PANELS have been made in thicknesses of from 1-8 to 3-8 of an inch. Instrument shafts have been made in quarter inch and three-sixteenth dimensions for no particular reason. One manufacturer's knob would not fit another manufacturer's condenser and some dials read from left to right and others from right to left.

This has caused considerable confusion and annoyance to the experimenter and the man who builds his own set.

"Many sets have been held up on account of not having dials to fit the condensers, and similar conditions all the way through. Not only has this been bad for the radio set builder and experimenter, but it has also been very difficult for dealers to know exactly what parts to stock.

With the formation of the Radio Manufacturers' Association, this was one of the first things that was brought to attention, and a Standardization Committee was formed, of which I was elected chairman. You can imagine the amount of work that we have before us. Everything is being done to overcome a situation which is fast leading to chaos.

"Many other industries have gone through the same process of adjustment and it has taken them from six to ten years to arrive at a point of standardization of parts. Although the Radio Manufacturers' Association has only been in



Mr. A. J. Carter, Chairman of the Standardization Committee of the Radio Manufacturers' Association who are leading us out of the wilderness of radio misfits.

By His Active Interest in STANDARDIZATION of Radio Parts

*A. J. Carter Inscribes his
name on the pages
of Radio History*

existence but a short time, much has been accomplished through the wonderful co-operation of manufacturers, dealers, and jobbers. Everybody realizes that the sooner we accomplish our aim, the better it will be for all concerned.

"Questionnaires have been sent out to the leading set manufacturers, radio authorities, and members of the radio press asking for their recommendations as to the proper sizes of dials, rheostats, shafts and other parts which at the present time are manufactured in a number of styles and sizes. Replies have been very interesting and have had a number of very good suggestions which are valuable in arriving at the logical standardization of the various items mentioned and also for other apparatus that is in need of standardization."

An Interview by
HOWARD I. SHAW

THE Standardization Committee of the Radio Manufacturers' Association is divided into a number of sub-committees, each taking some particular phase of the industry, and headed by a manufacturer prominent in that line as a sub-committee chairman which are as follows: Wiring devices, P. C. Lenz; condensers and dials, H. A. Bremer; rheostats, Charles Hardy; transformers, J. A. Bennan; loud speakers, head sets, and phonograph units, E. H. Clark; storage batteries, Dr. W. E. Holland; dry batteries, W. A. Brennan; plugs, jacks and switches, Godfrey Gort; sockets, Walter C. Huth; receiving sets, A. A. Howard; symbols, George Lewis; test instruments, John Miller; arresters and aerials, H. O. Larsen.

Other committees are being planned and men of national repute will head them as the need arises.

The ultimate aim is to standardize every part that enters into the construction of a radio set and that the standards will be followed by the radio industry as a whole and result in the saving of considerable time and money by everyone connected with the radio industry. Standardization will stabilize the radio industry, which again is a benefit to everybody, especially the fan.

One can readily understand the confusion that a dealer and a consumer are up against when a consumer walks in to a

dealer and asks him for a certain dial and is unable to know exactly what size he requires because he has not taken the measure of his shaft. A dealer is prohibited through no fault of his own from rendering a real service to the consumer.

Will Promote Growth of Radio

THE radio industry has had without doubt the most phenomenal growth of any industry in recent years and it is a matter of keen congratulation to all connected with it that those interested in the radio industry have been far-sighted enough to get together and form such a committee.

Mr. Carter and his various associates have done a tremendous amount of work and the radio public is fast beginning to appreciate what this has meant for them.

The purchasers of radio parts who buy from manufacturers that are heart and soul behind this movement, have every assurance that the product is all that the manufacturer claims for it.

Radio's Wandering Minstrels

*The
Happy
Scotch
Trio,
who are
Devoting
Their
Lives to
Making Us
Happy,
and Why*



The Scotch Trio, shown at the left practicing the Highland Fling, are, from left to right, William H. Wallace, Piper; Everett S. Dodds, vocalist, and Robert Malcolm, drummer.

EVEN after the few short years of its existence, radio broadcasting is so standardized that to be different and original is a huge task in itself. Radio singers, musicians and announcers are so much alike as to almost invariably fall into a specified category, such as "Dignified," "Humourous," "Classical," "Crude," ad infinitum.

Naturally, the really popular entertainers in the radio field are those that can make a super-human effort and turn out some form of entertainment that, while not exactly new, is at least unique and a welcome surcease from the monotonous programs to be found at nearly any station on the air these days.

The "Scotch Trio," a group of Scotch singers and musicians who got their start from Station WOAW in Omaha a couple of years ago, realized the handicap of monotony that they must overcome; and, being Scotch, they had no trouble in devising a scheme that was both inexpensive and original.

OUTFITTING themselves with Scotch "kiltie" uniforms, and purchasing a set of bagpipes and a real Scotch drum for their music, they introduced themselves very seriously at WOAW in 1922 and were likewise taken seriously. As they explain dexterously, if you make people think you're serious and important, they'll be convinced you are. Simple, isn't it?

By MARGIE SANDER

Another of Miss Sander's Accounts Telling How Radio Luminaries Got Their Start

They appeared consistently at WOAW in typical Scottish folk songs, at which they were most adept. Soon they began to travel,

and now, after more than two years before the microphone, always in the kilts of their motherland, they are nationally known for dispensation of happiness and good cheer.

"We have one outstanding reason why we continue to get so much fan mail, after all these months of playing the same numbers," Everett S. Dodds, the manager and chief vocalist of the trio, explains.

"Scotch songs are mostly songs of home in the country, and mother, and the sweet little lass you used to know. Such an appeal finds a quick human response in anyone's heart. And we can sing the same songs differently every time. That does away with monotony. And the familiar combination of bag-pipes and drum never grows old. Our entertainment is always new, yet ever the same."

The other members of this very interesting trio are William Harry Wallace, piper, and Robert Malcolm, drummer-in-chief.

Anyone who has ever seen a group of Scotch musicians play can well appreciate the antics of the drummer. Robert Malcom is an expert at drum technique, and the studio of the station where the trio performs is usually aroar with laughter at the whirl of the drum-sticks.

Revealing the Identity of

THE VOICE OF THE AIR

"Yes Sir
and
Yes Ma'am"

By
L. A. McCormick

He Broadcasts
Two Hours of
Sunshine and
Happiness Daily



The Voice of the Air is no longer a Mystery. Here we have his photo seated before the "mike" of WBBM where he made the slogan popular.

THOUSANDS of radio enthusiasts in the great midwest are familiar with the unusual phrase "Yes Sir and Yes Ma'am," and "You ain't heard nothin' yet" and many times you have heard the unsatisfying explanation "This is the Voice of the Air" as the only clue to the identity of the individual using these phrases. The repeated use of the slogans excited my curiosity, and accordingly I determined that I for one, was going to know who the voice belonged to.

The slogans have been coming in through my loud-speaker via WBBM on the North Side Realty Company programs, and inasmuch as they have invited the radio public to visit them I availed myself of their invitation, and meandered to the downtown studio in the Chicago Loop.

Realizing that many of you are wondering just as I did over the owner of the "Voice of the Air," I am lifting the mystery, by telling you what I found out.

The Voice of a Pleasant Fellow

DURING the introduction I learned that his name is Phillip Leon Friedlander. He is a tall dark young man—some five feet eleven inches in height. He prefers to remain somewhat of a mystery, though I can't see just why he should do so. Wouldn't tell me if he was married, nor would he divulge his age. So there you are.

As the interview progressed he abandoned much of his initial reserve, and by careful and tactful "pumping" he made the following admissions, around which I am building my story.

When I asked him where he was born, he said "Chicago."

I then asked him where he went to school. The reply came, pleasantly and not without a trace of amusement:

"Chicago."

"Did you go to college, what did

you study and what did you do after you got out?" was my next string of interrogation.

"In the East. Law. Went to war with the French."

"Then what did you do."

"Worked."

"At what?"

"Advertising."

"How do you like the work as a radio announcer?" I ventured in desperation.

A look of satisfaction spread over his pleasant face as he said, "Ah, that's better. Let's talk about my work. I'd much prefer to do that than to talk about myself."

"Radio announcing, as I look at it, consists of the ability to put yourself in the position of a listener while you are talking, and then to make yourself so interesting and unobtrusive in the progress of a program that you be come a part of it—without losing your individuality. That's all. Keep the fellow at the other end foremost in mind, and your sincerity will help you to "click" over the air.

"The 'Yes Sir and Yes Ma'am' phrase I use so often is part of this idea of broadcasting. It identifies our programs immediately. "Two Hours of Sunshine and Happiness" is another slogan that I use frequently in announcing because I believe that a phrase of that calibre, oft repeated, has the psychological effect of helping to make the radio audience happy and receptive.

"The Voice of the Air' is a copyrighted phrase that I use instead of my name, because I believe the listening public is more interested in my part in the program than they are in me as an individual. If I make 'The Voice of the Air' sufficiently pleasant and interesting, they naturally will become interested in what constitutes the voice; if I make myself unob-

|| This is One of the
Many Exclusive In-
terviews With An-
nouncers That We
Have Been Printing
Each Month. How
Do You Like Them?
EDITOR. ||

(Turn to page 63)

ON THE AIRIALS

ITEMS OF GENERAL RADIO INTEREST

Handpicked by Ray D. O'Nutt



THE City of Zanesville, Ohio, is trying to keep the ether free from interference, forbidding the use of vibratory battery chargers during broadcast reception periods. An ordinance recently passed there rules that battery chargers of the vibratory type for charging radio batteries shall not be operated between the hours of six p. m. and 5 a. m., and that offenders shall be held guilty of misdemeanors and may be fined not more than ten dollars.

Entertain Rum Runners

How a law abiding radio broadcast station was inadvertently aiding a group of rum runners was brought to light recently by a letter received by the Glenn C. Smith orchestra at WAHG, Richmond Hill, Long Island. The letter from somewhere off Long Island and post-marked Babylon follows: "Dear Glenn C. Smith:

"Don't know whether you will be flattered or not but ever so many rum runners have dubbed your band 'The Bootleggers Own.'" We hear you so often from WAHG and that station goes out over the water in great shape. Men who go down to the sea in ships at night enjoy your music—especially the late programs. About midnight when you come on we are getting ready to nose into the creeks and bays with our cargo. Our radio picks up your jazz and it makes the boat seem like a pleasure craft. On several instances the Coast Guard has been fooled on account of your jazz numbers from the Grebe station. Your dance orchestra sure is appreciated even though we are in no position to do any jazz steps. More power to you.

"Canada Redtop; Toronto Slim & Brunswick Bill."

Sailors Like Radioplays

To the deep-sea sailor, the radio play is a "gift of the gods," according to a report from a listener on the S. S. Meton, plying the Pacific Ocean.

"On behalf of the officers and men aboard the S. S. Meton I wish to express commendation for the plays broadcast by KGO," reads a letter selected from the daily mail-bag of the General Electric Pacific Coast broadcaster. "The radio play is yet the greatest improvement in broadcasting. It is especially a 'gift of the gods' for the sailor—the deep sea sailor.

"We are all head over heels in love with the sweet voices of the ladies in the plays. And if we had women aboard there would no doubt be some broken hearts over your radio 'shieks.'"

Loud Speakers Without Batteries?

I hear again of a crystal set which will work a loud-speaker as efficiently and clearly as a valve set. The new set, it is claimed, will cause a revolution in the crystal set world. It has not the range of a valve set, however, and is consequently only suitable for working off the local station.

The general opinion among experimenters is that enough energy to work a loud speaker cannot be collected by an aerial alone. The incoming waves must be assisted by locally applied power in some form or other. Should a crystal loud-speaker using no batteries make its appearance, it will be perhaps the greatest stride forward since the beginning of broadcasting, but the bulk of opinion seems to be against the possibility.

There have been various statements about crystal loud speakers in the past,

so we must take the announcement conservatively until it has been definitely proved a set which can be easily handled and produced at a commercially sound price.

Grimy Aerials Don't Work

About 25 per cent of the listeners in the British Isles were finding reception poor during January, and could give no reason for it. For once they could not blame the atmosphere which was clear and bright enough.

It was the Great Fog of the first week. All those who are in fog zones should look to their aerial connections, and the chances are that they will find them thickly coated with a deposit. Remove it, and you will find reception back to normal again.

As a matter of fact—and this point cannot be stressed too much—most people are apt to let their aerials look after themselves forever. The aerial and aerial connections should have a periodical examination at least every three months, for remember, it is usually exposed to some strain or other every hour out of the twenty-four.

How to Sell Radios

A radio program, coming in at the moment a set is being demonstrated, has a lot to do with making the sale, according to a prominent San Francisco radio dealer.

"When a customer comes to my store to buy a receiver," he writes, "I always size him up to see if he is a 'jazz-hound' or not, and when demonstrating a set I try to tune in the thing he likes. I have found that the man who dislikes jazz may refuse to buy if jazz happens to come along at a moment when he is still in doubt. A woman's talk on fashions or cosmetics may ruin the sale to a man, whose wife would be just as much upset by a man's talk on banking or sales psychology. 'I don't want any of that stuff in my house,' is just as likely as not to be the verdict.

The best radio feature from a sales point of view to which customers may tune in, is undoubtedly music, and music that is neither too highbrow nor too low. Music is not only pleasing in itself, but has the merit of being non-controversial and universal. It hurts no one and gives a certain amount of pleasure to everybody.



PIRATES AHOY!

"Terrible Terry" Yagle who is either protecting or kidnapping "Princess" "Goo Goo" Downs on one of the 'pirate ship' broadcasts from station WBCN Chicago. The Princess doesn't look a bit afraid so we are inclined to believe she's being protected and not kidnapped.

All About WSMB—New Orleans



☞ Radiates
500 Watts
of Pep,
Syncopa-
tion,
Classics and
Happiness



By MARVIN PLOTKE

NO "DX" fan can ever boast himself a distance getter unless he has logged WSMB of the Maison-Blanche and Saenger Amusement Company, Ltd., New Orleans, La. This station has well earned a number on the dials through its excellent programs. Just for curiosity, let us make a visit to WSMB.

Inaugurated April 21, 1925, it was situated atop the Maison-Blanche building. With the studios it comprises a series of rooms on the thirteenth floor. We step into an elevator which carries us direct to the reception foyer. This is furnished in Spanish treatment, with draperies, lighting effects, plastic walls and rubber tiled floors. This we are told is to deaden noise. The foyer leads into the studio.

We gaze into the specially designed studio room, encased in a maze of draperies, padded ceilings and walls and with curtains operating on draw strings to effect various acoustical changes. The microphone is the only mechanical equipment in the studio outside of the concert grand piano which stands beside it. Restful lounges, wrought iron chairs, Castillian settees add the final equipment for the studio. Walking through an outer corridor, we bump into an ante room where a battery of Western Union and Postal Telegraph instruments are clicking merrily. Along the wall are ear-o-phone desks for the telephone operators who acknowledge "fan" applause. A floor constructed to nullify vibration or even the slightest noises leads into the operating room, where the transmitter is located.

This room has a series of plate glass panels so that visitors to the studio can view the equipment without disturbing the engineer in charge. A separate chamber houses the motor generator that "kicks-up" 2,000 volts. In the operating room there are the remote control wires leading to St. Charles, Strand and Liberty theatres. The technical and operating staff at WSMB

Radio listeners throughout the middle west and south are well acquainted with the Owl Orchestra, a red-hot Southern band that plays jazz as it should be played. At right, Clyde R. Randall, announcer and program director of WSMB



is at present preparing to install a portable remote radio control on a truck for the "radioing" of events from various parts of New Orleans.

The transmitter is of the 500 watt type and the wave length is 318.9 meters. Upon gazing at the huge towers we are told they are 126 ft. high and are of fabricated steel to withstand wind pressure to a maximum of 125 miles per hour. The aerial is a flat top "T." The total effective flat top is 57 feet, bisected by the "lead-in." The total height of aerial above Canal street, New Orleans, where it is installed atop the Maison-Blanche building, is 305 feet.

The WSMB Staff

NOW for the staff that makes the wheels go round. William H. Gueringer, assistant general manager of the Saenger Amusement Company, is director general of WSMB. Clyde R. Randall is director and announcer. The rest of the staff personnel consists of a program director, engineer and two radio operators, the stenographer and telegraph and telephone operators.

WSMB is a comparatively new station down south, yet-to-date more than fifty thousand letters and telegrams have been received. They have come from all sections of the United States, Canada, Mexico and Central America. During the summer months every state in the Union reported reception at full blast. It is a station well worth tuning for.

Congress Gives RADIO BILLS Audience

By CARL H. BUTMAN

Washington Correspondent for ON THE AIR

IF EITHER of the radio bills recently submitted to Congress pass, it is believed Secretary Hoover will be granted sufficient authority to regulate and supervise radio communication within the United States, and keep the ether lanes free from interference.

The desires of the Commerce Department and the recommendations of the Fourth National Radio Conference have been incorporated in both bills introduced and steps to hold a joint hearing on them, are under way. The first bill presented is that by Wallace White of Maine, who has revised his last year's bill to cover most of the conference recommendations. This House Bill is listed under the title HR 5589 and has been referred to the Committee on Merchant Marine and Fisheries.

On the other side of the Capitol, Senator C. C. Dill, of Washington, who although representing a state very distant from Maine, apparently is close to Congressman White as far as his views on what radio legislation is needed are concerned. The Senate Bill, S1754 has gone to the Interstate Commerce Committee. It will be recalled that Senator Dill also endeavored to father the Senate radio bill last year.

Broadcast Listener Protected

AS FAR as the interests of the broadcast listeners go, they seem adequately protected in both of the pieces of proposed legislation. Secretary Hoover, or rather the Secretary of Commerce, is clothed with power to regulate radio communications in the interest of public needs and, of course, radio broadcasting is included.

The White Bill is designed to replace the obsolete and inadequate Act to Regulate Radio Communication approved in 1912, which of course the Dill Bill also seeks to do. Mr. White provides that: The Secretary of Commerce shall classify licensed radio stations and the operators; prescribe the nature of the service rendered by each class and each station; assign bands of frequencies or wave lengths to the various classes and to each station, determining the power which each station shall use and the time during which it may operate; determine the location of classes or individual stations and the kind of instruments to be used, with respect to their external effects; regulate the purity and sharpness of the emissions from each station and its apparatus; establish areas or zones to be served by stations; inspect licensed stations and their apparatus; make such regulations not inconsistent with law as he may deem necessary to prevent interference between stations and to carry out the provisions of this Act; provided, that changes in the call letters, wave lengths, authorized power, in the character of emitted signals, or in the time

¹This section of the bill if in force now would eliminate the WJAZ "Piracy" litigation. It shows excellent foresight.
²Hurray! This ought to eliminate some of the vicious tinpanning we've been subjected to. —Editor.

HR5589 and S1754 Excellent Pieces of Legislation in the Interest of Listener

of operation of any station shall not be made without the consent of the station license unless in the judgment of the Secretary such changes are required as a public necessity or interest.

Secretary Clothed in Power

Other sections of the proposed act require that in time of war or emergency, the President may close or take over radio stations.

No operating or station licenses will be issued to other than law-abiding American citizens, and it is provided that licenses, and channels may not be transferred without the approval of the Commerce head. Station licenses will be limited to a term of five years, with the privilege of renewal at the discretion of the Government's radio officers, but fees are not prescribed. All new station licenses will be issued only upon application and following the issuance of a construction permit.

Appeal

Applicants denied permits or licenses or whose papers are revoked will have the right to appeal to the Court of Appeals of the District of Columbia over the rulings of the Secretary of Commerce.¹

A special section of each bill provide that all laws relating to monopoly, and combinations to restrain trade apply to the sale and trade of radio apparatus coming within the interstate commerce laws.

Advertising

MATTER broadcast from stations for pay, directly or indirectly, must be announced as "advertising", except when the advertisement consists solely of the name, business or address of the firm or

person providing an entertainment feature, in which case the announcement will indicate that the feature is "paid for or furnished by" the individual or firm.²

Rules for the issuance of operators' licenses prescribe that only proficient applicants will be licensed in the several classes and that the term of license shall not exceed two years. These licenses may be suspended when the Secretary of Commerce learns that the operator has violated regulations and laws; for example, if he has damaged radio apparatus, caused interference willfully or maliciously, or sent out communications containing profane or obscene words or language.

Permits to construct all land stations except amateur, mobile, and experimental stations will be required after the law is enacted, a requirement being that a public convenience, need or necessity is to be met. This measure will hit some of the organizations and individuals seeking to erect broadcast stations in communities now believed adequately served by existing stations, but on the other hand may save impractical investments in stations.

Both Messrs. White and Dill provide in their Bills for radio commissions to be appointed by the President to aid the Secretary of Commerce in solving difficult problems. Mr. White suggests a membership of nine and Mr. Dill, of five. The first meeting would be held in Washington, other sessions where and when deemed desirable. Decisions of the Commission would be binding upon the Commerce Secretary but appeals from them would be in order through the Courts. Dr. Dill specifies that the amateurs and broadcasters be represented on the commission which he simply terms a Radio Commission, while Mr. White is more exact in name, calling it the National Radio Commission, although he does not recommend any special representation on it.

Senator Dill forbids anything resembling censorship by the Government such as might be termed interfering with the free speech, except as applied to obscene matter.

SOS Signals Protected

Both bills provide for adequate protection of marine interests, including the immediate right-of-way to distress signals and their handling.

An interesting angle of both bills is the definition of radio communication which now covers the transmission of any intelligence message, signal, power, pictures or communication of any nature transferred by electrical energy; they also specifically forbid the transmission of any false or fraudulent message or signal or rebroadcast without permission. Even the possible transmission of power is anticipated. Bill S1754, provides against rebroadcasting unless the permission of the originating station is secured. Senator Dill also provides for the use of the minimum power

(Continued on page 59)

LAST MINUTE NEWS!

OUR Washington correspondent, Mr. Carl H. Butman, wires us that no developments of vital importance have taken place in Congress on these bills as we go to press. Hearings on the White Bill (HR5589) have been concluded and the bill has been referred to the radio sub-committee. Hearings on the Dill Bill (S1754) are yet not complete. In general the attitude taken toward either bill is very gratifying, though there seems to be a tendency to favor the White Bill for its more comprehensive treatment of technical detail. Statements have been issued by prominent men calling the White Bill a "masterpiece."—The Editor.

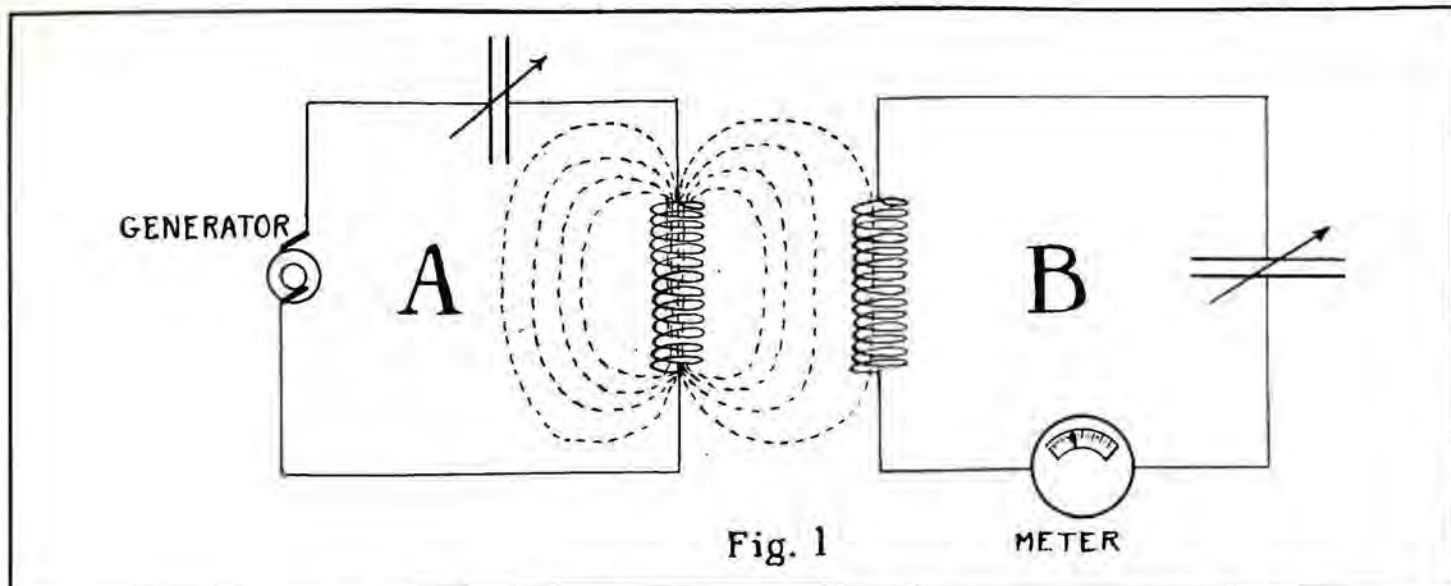

Fig. 1

The Function of the Coupler in your Receiver

"YOU KNOW," said my inquisitive friend with the new broadcast receiver the other night, "this radio business is a peculiar thing. I can't understand it; so many things in it seem to contradict each other. Of course, I suppose it's all because I don't understand the principles, but at the same time many of the statements I see in the papers seem foolish."

"Well," said I, "I guess perhaps you're right—some things in radio do seem to contradict each other, but as you surmise, the seeming contradictions all fade away when you follow them down to their basic principles. What is on your mind, now? Perhaps I can help you out?"

"It's in regard to couplers," said the new BCL. "What is the purpose of a coupler anyway; what good is it? In a receiving set they tell you that the idea is to get as much as possible of the energy set up in the aerial circuit by the incoming wave, into the grid circuit of the first tube. That on the face of it is logical and reasonable in every way, but why, then in the same breath, do they tell you to use an antenna coupler in which the aerial coil is removed from the grid coil by a distance of from $\frac{1}{4}$ of an inch to an inch

What is the Purpose of The Coupler, Anyway? What Good is it in your Receiver? Questions the BCL Asks About the Well Known Coupler Answered with Surprising Clarity in this Confidential Across the Desk Talk

With
Andrew W. Kramer

or more? Why separate the coils or why use two coils at all? Why not attach the aerial and ground directly to the grid?

"Of course, I know that the coupler is supposed to make the set more selective, but I still cannot see why we should deliberately put from $\frac{1}{4}$ to 1-inch of blank space between the primary or aerial coil and the secondary or grid coil of a coupler when we are trying to conserve energy. Blank space to my mind is detrimental. What has—"

An Interesting Point

"I SEE your point," said I, interrupting him. "You don't understand why moving the coils away from each other can make the set more selective. Is that it?"

"Exactly; what has selectivity got to do with separation of the coils?"

"I believe I can make this thing clear to you," said I, "but in order to do so I will have to discuss briefly

the principles of coupled circuits. To begin with, in order to set up an alternating current in a closed circuit, and in radio you know we are always dealing with alternating currents, it is not necessary to connect that circuit directly to an alternating generator or other

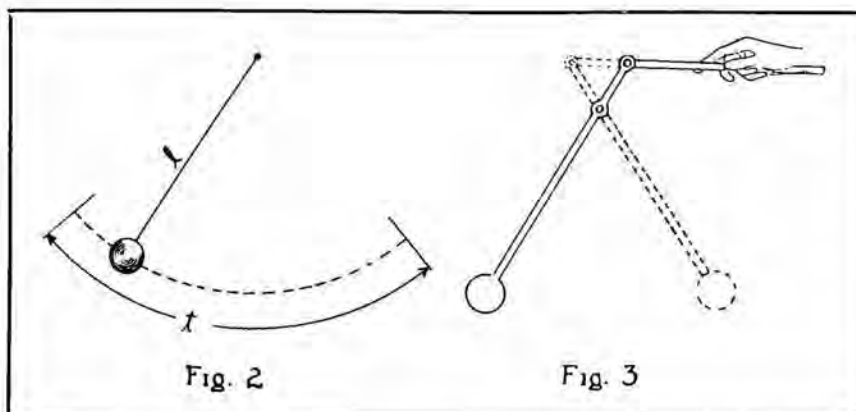

Fig. 2

Fig. 3

With Many Stations Coupling Must Be Adjusted at an Average Value—Not so Loose As to Eliminate Distant Stations and Yet Not so Close as to Make Locals Heard Over the Entire Dial—

**—SAYS
9 C P V**

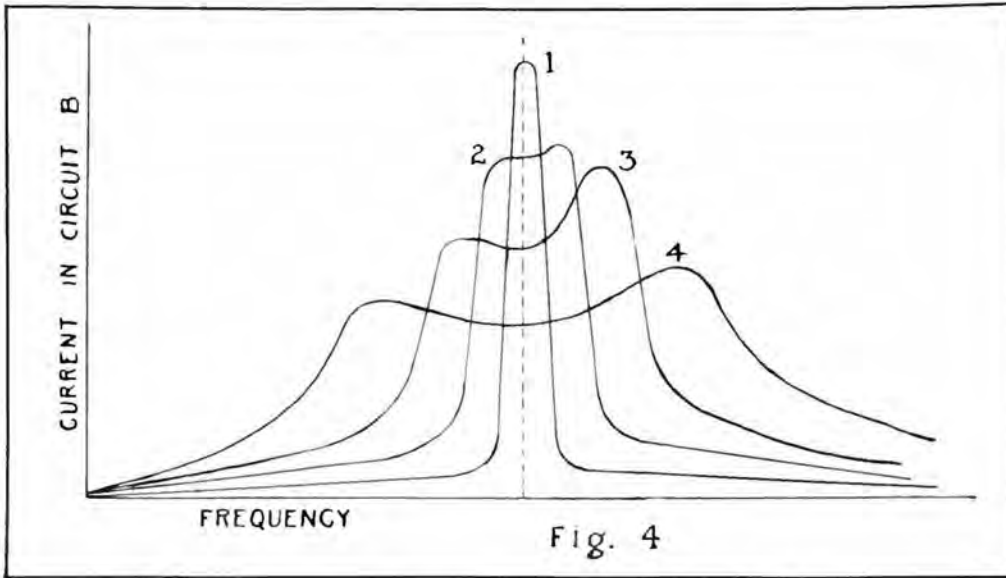

Fig. 4

the circuit in which the current is set up.

"While this is not the only way by which two circuits may be coupled, for the sake of simplicity we will confine our discussion to this method; that is by the use of two coils placed near each other. Now it can be shown, mathematically, that a circuit containing a coil and a condenser as at B will possess a certain natural frequency; that is, an alternating current will flow back and forth in it a certain definite number of times per second depending upon the size of the coil and the condenser. If either the coil or the condenser is changed

source of alternating current. It is sufficient merely to place the circuit or a part of the circuit in an alternating or pulsating magnetic or electrostatic field. "This may be better understood by comparing such

In Fig. 1, for instance, we have a closed circuit B in close proximity to circuit A which contains an alternating current generator. Part of the magnetic field due to the coil in circuit A intersects coil of circuit B and produces in circuit B an alternating current of the same frequency as that flowing in circuit A. Two circuits acting upon each other in this manner are said to be coupled. They are referred to generally as the primary and secondary circuits, the primary circuit being the one producing the field and the secondary,

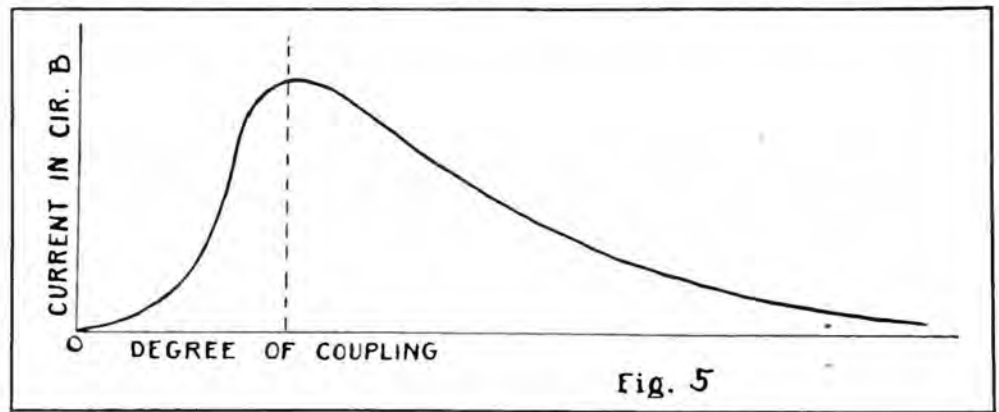

Fig. 5

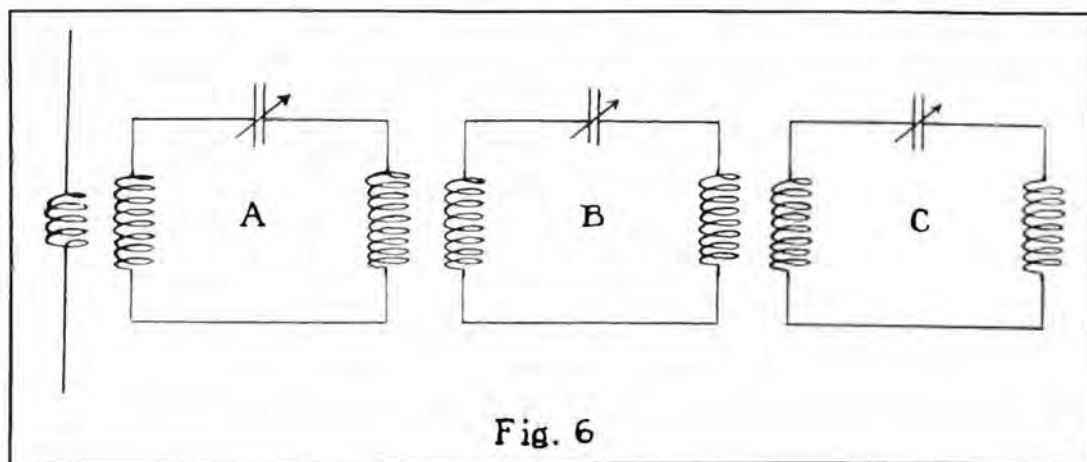
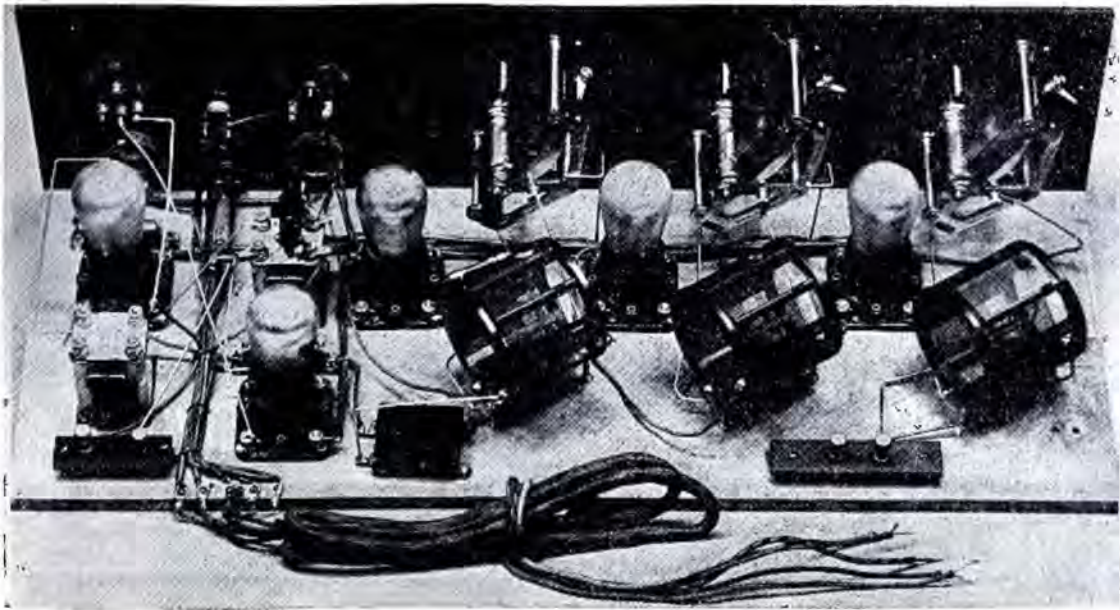

Fig. 6

a circuit with a pendulum. The time of the swing or the number of swings per unit of time, of an ordinary pendulum such as shown in Fig. 2, is determined solely by the length of pendulum, not by its weight nor by the amplitude of its travel. A pendulum a yard long for instance has a period of 1 second. If we wish to change the time of the swing we can do so by making the pendulum longer or shorter; shorter if we want it to go faster, longer if we want it to go slower.

(Turn to page 59)



Here's How to Make a
**1926 MODEL RADIO
 RECEIVER**

By THE TECHNICAL STAFF

DURING the past two months the Research Laboratory has in the course of advising radio fans, done a tremendous amount of work. Immediately after the publication of the offer to help out with expert buying advice we were literally swamped with mail, and even at this writing the force is working at top speed to help readers in the selection of the best radio has to offer.

In the course of answering these inquiries we have noticed that the readers are all favoring receivers of five tubes, and prefer to have a set assembled of such parts as have been tested and approved by the Research Laboratory. So in off moments we have for the past three months experimented with a five tube receiver, composed of such parts bearing the certificate of approval and merit of the testing department. The results have been particularly gratifying, and we are offering herewith the result of this experimentation believing it to be just as good if not a better radio set than any that has as yet been put out in the five tube class.

Some of the Features

We are fortunate in being able to use the exceptionally good Karas condenser with the Proudfoot coil which has just made its appearance on the market. The characteristics of both the coil and condenser are such that they make an excellent match. The tuning is well spread on the lower wavelengths by virtue of the Karas Orthometric shaped plates, and the combination of the low losses of the Karas condenser and the

*Has "Diminuendo"
 Knob to Control
 Output of Audio
 Amplifying Stages*

sharpness of resonance of the Proudfoot coil makes an admirable tuning combination.

Stabilization is accomplished by the use of the popular Centralab plate resistance which is about the most efficient method of receiver stabilization in current use.

One of the outstanding features is the use of a modulator in the last audio stage. This eliminates the necessity of detuning the set (which always distorts) when listening in on local stations of considerable volume, and also obviates the necessity of jacks to accomplish the same thing. A gentle turn of the "Diminuendo" knob as we have termed it, turns the roar of a local station into the softest concert. It lends the much sought color to the radio program that fans have long been seeking.

With regard to selectivity, we contend that the set is considerably better than the average radio set now on the market. We are not averse to admitting that if operated in the shadow of a broadcast station which has wide sidebands that trouble will be encoun-

tered with interference. We have yet to see a tuned RF receiver completely obliterate the signals of a station in close proximity and tune in long distance with any degree of satisfaction. For the type of fellow living within five miles of a thousand watt station we emphatically recommend a super-heterodyne. There have been numerous instances where even the super has been bothered with harmonics and mush in locations directly adjacent to broadcasting stations.

We believe this set to be an efficient 1926 model RF receiver, that is simple to assemble and wire, and that will avail gratifying results to the enthusiast who has what might be termed a "decent" location. If you consider building this model, and feel doubtful as to whether or not it would be effective in your location, write us, and we'll be glad to appraise your locality for you.

Don't Substitute

ONE of the important things we wish to stress is the necessity of sticking to the specifications if results are to be a certainty. In this set we have endeavored to match as closely as possible the devices tested in our laboratory with corresponding equipment that we know will perform.

This matching process is characteristic of the entire set. If substitutions are made in the tuning circuit equipment, we cannot guarantee that the entire broadcast range will be covered effectively. If you substitute tubes with different effective impedances your results will suffer likewise. If you change audio transformers, it becomes necessary

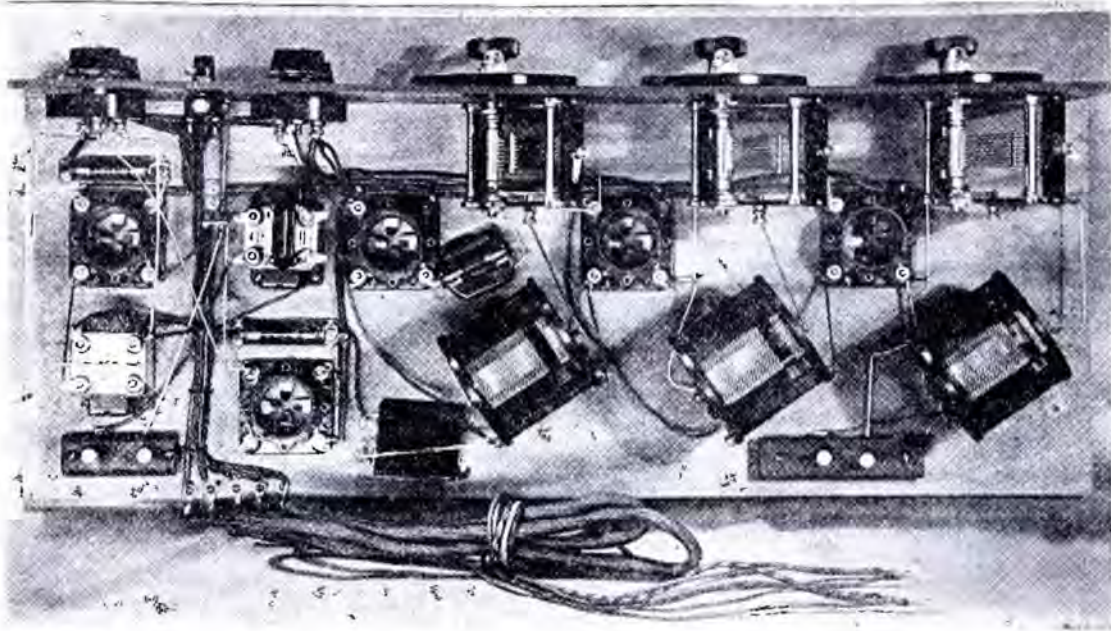

These graphic photos and mechanical sketches should make the constructional details clear to the set builder. The numbers on the top elevation below simplify the wiring from the schematic diagram on the next page.

to use another series of Musselman tubes. If you substitute a different loudspeaker, you must select one that comes close to the characteristics of the Burns if you wish to avoid distortion in the last audio stage. The best policy is to adhere to the specifications, and little or no difficulty will be encountered in getting the results you are after. Nearly all of the equipment is advertised in ON THE AIR, and you can easily assemble the essentials from information obtained by scanning our ad sections.

How to Build This Set

AT THE outset let us caution the rank beginner that the exercise of a little hard common sense will save a lot of money and grief if our instructions are followed. To understand our instructions, it is necessary that you know something about radio before we can talk in radio terms. No one ever drove an automobile by getting into the driver's seat and pressing a lot of pedals and controls. No one ever made a radio set and got results unless at least partially acquainted with the undertaking. If you are entirely ignorant of what radio is our advice is that you get a copy of "RADIO THEORY" (advertised somewhere in this issue) and study up for a week or so before you attempt to build a device that deals with frequencies upwards of a hundred thousand oscillations per second.

Then buy your parts. Use the list on page 35 and stick to it. Don't start your building until you have everything in readiness. The temptation to "use something just as good" is too great.

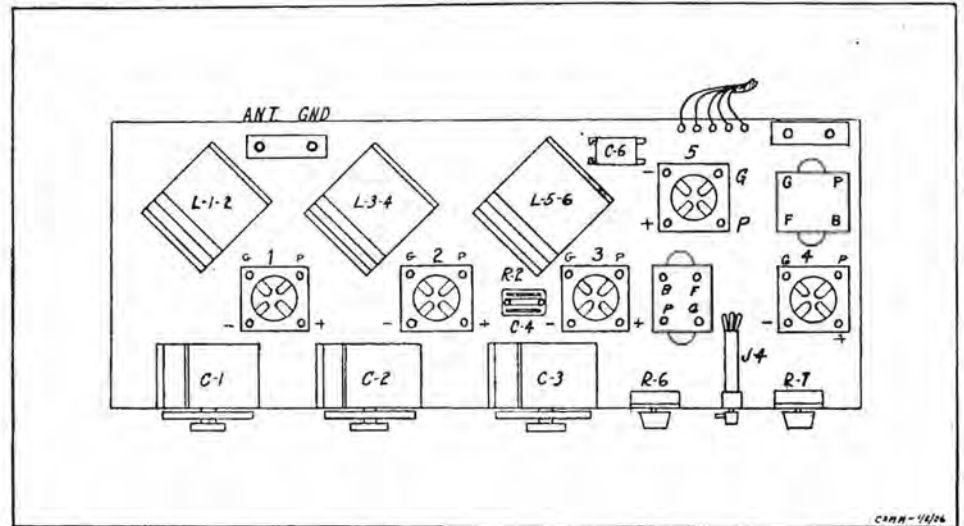

Lay the panel out, using the template shown on this page. Refer to the photographs if you are in doubt about the drilling. The sizes for the holes with the specified apparatus are correct, and if you follow it closely, you will not have trouble in assembling.

Assembling

Mount C1, 2 and 3 so that they all tilt at the same angle. Use the stop screw of the Marco dials as guides by swinging the condensers so that the top of the end plate just touches the stop bolt of the Marco dial, which is drilled three-quarters inch away from the condenser shaft hole. Then mount R6, 7 and R1 and R3. Screw J4 to the panel and the filament switch FS into place.

Be sure to get the OFF and ON positions correct.

Next turn to your baseboard. Mount it to the panel temporarily with the gun-metal finish screws (S). Using the condenser shafts as guides drill holes for the supports for the Proudfoot coil, the guide hole being directly back of the condenser (C1, 2 and 3) shafts two inches away from the back edge of the baseboard (BB). Draw a line at a 55 degree angle using the back edge of the baseboard as guide through the hole you have just drilled. Then measure along this line two and one-eighth inches and drill another hole to accommodate the support for the Proudfoot coil. If you do this properly, all your coils will be at the same angle, which is very necessary for best results.

Spot the tube sockets, transformers and binding post racks by eye, using the photos as guides. Screw them down into place when you have them all in place according to the drawing and photos. They are not likely to affect the set if they are off an eighth of an inch.

Next remove the variable condensers (an easy job after you have once learned how they go on) and you are ready to proceed with your wiring.

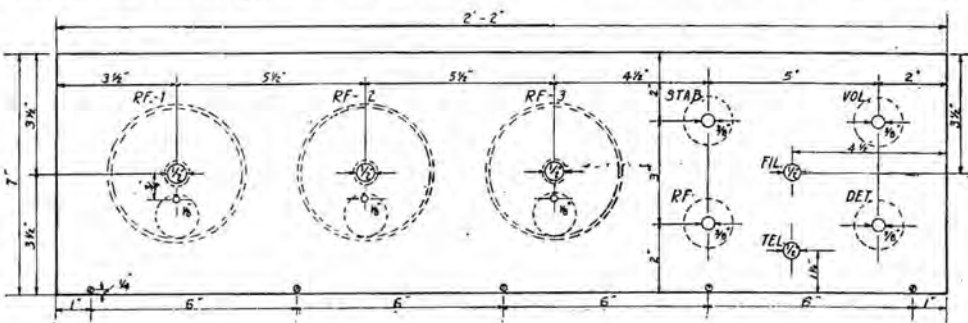

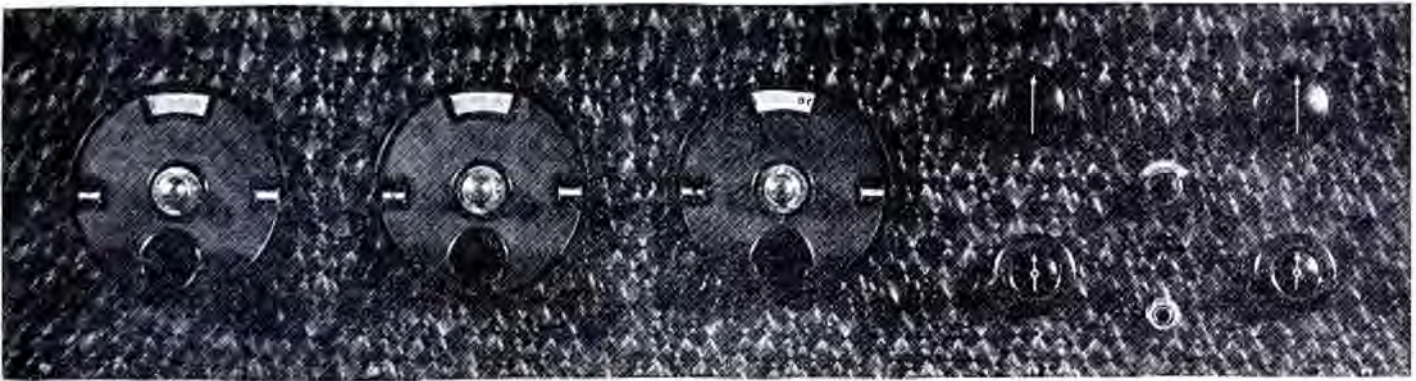

The front panel view of the receiver described herewith is one of simplicity and beauty. All the tuning control: to the left, and the stabilization and power controls on the right. The knob in the upper right hand corner of the panel is the "Diminundo" control of the signals.

Using the Belden hookup wire connect up all the plus posts on the tube sockets; then connect the entire tieup of plus posts to one terminal of the filament switch. The other terminal of the filament switch goes to the soldering lug for the Belden Battery Cable on the back edge of the base board.

Next wire the negative filament circuit according to the schematic plan on page 35. All the details are plainly marked, and if you have patience and are willing to apply yourself you should have no trouble in studying out the plans. Remember that the lines in black are to be wired in Belden Hookup wire, and the lighter lines in the set itself are in busbar. The lighter lines issuing from the battery connections are representative of the Belden battery cord running to the batteries.

After the negative filament circuit has been completed and all the connections soldered into place, solder the Belden Battery cord to the two posts you have selected for the A battery. Use yellow and black for A plus, and the plain yellow for the A minus. Connect the terminals of the cord to the proper polarity of the A battery, and then test your filament circuit by putting your tube in the sockets. If they light, and if the rheostats R1 and R3 control the first, second and third tubes your wiring is correct. The tubes 4 5 are fixed in brilliancy and you need not worry about them so long as they light up.

Now screw your condensers back on the panel, and mount your dials. Resume the wiring by connecting up the antenna and ground posts. The terminal connected to the ends of the small coil L1 are wired to the ANT and GND posts respectively, the ground connection being taken off the end nearest the largest coil L2. The third terminal on the end of the antenna coil (L1, L2) is wired to the minus A line. The single terminal on the other end of the coil frame is wired to the stator plates of the variable condenser C1 and a wire is run up to this connecting medium from the G post on socket 1 and soldered thereto. Proceed with the wiring of the RF stages using busbar where the lines are light on the schematic drawing, and rubber covered hookup wire where connections are ordered in dark lines.

The grid condenser C4 and grid leak with the clips are soldered directly to the G post of the detector socket (3).

Follow the diagram straight through from the antenna to the audio jack making the connections firm and strongly

soldered. Use a good hot iron in your work, and apply soldering paste sparingly. We found it a good plan to tie the bunched cable to the baseboard by drilling small holes through the baseboard and tying the bunched wires down by threading the string, around the wires, then threading them through the holes and tying.

The Antenna

THE proper antenna to use with this set depends largely on location. If you live near any great number of broadcasting stations, or if you have trouble with interference, cut down your aerial till your trouble alleviates. In tests we find that the set functions very well indeed on short outdoor aerials, and also very effectively on short outdoor aerials about 65 feet total length.

The fellow living out in the country has the advantage in this case. He can afford to use a larger antenna with correspondingly greater signal input because he does not require so great an amount of selectivity.

Before you connect all the batteries, it is discreet to check over the wiring once or twice conscientiously, to locate possible errors. And after you have wired the whole set and feel that you are ready, don't put all the tubes to work at once. Use one tube and test each socket. Then if you have made mistakes, you'll only lose one of your tubes instead of five.

THE LIST OF PARTS	
P	Bakelite Panel 7X26X3-16 inches Duco finish
BB	Baseboard 10X26X1-2 inches Spar Varnished
D	Marco Dials (3) Clockwise
S	Mounting Screws (5) Blue finish 3-4 inch long
FS	Carter Filament Switch (1)
J4	Carter Four Spring Jack (1)
L1, 2, 3, 4, 5, 6	Proudfoot Coils (3) .00035 Mfd. size
C1, 2, 3	Karas Orthometric Condensers (3) .00037 Mfd.
4	Sangamo Fixed Condenser (1) .00025 Mfd.
5	Sangamo Fixed Condenser (1) .001 Mfd.
6	Sangamo Fixed Condenser (1) .5 Mfd.
BC	Belden 5 wire Battery Cable (1)
R1	Carter 15 ohm Rheostat (1)
2	Daven 3 megohm grid leak (1) Mount to match
3	Carter 25 ohm Rheostat (1)
4	Amperite 1A (1)
5	Amperite 112 (1)
6	Centralab 200,000 ohm plate resistance (1)
7	Centralab Modulator (1)
T1	Thordarson 2:1 AF transformer (2)
2	Thordarson 2:1 AF transformer
TS	Benjamin Tube Sockets (5) UX or UV
1	Musselman UV or UX 201A Series 4 tube (2)
2	Musselman UV or UX 201A Series 4 tube
3	Musselman UV or UX 201A Series 3 tube (1)
4	Musselman UV or UX 201A Series 2 tube (1)
5	Musselman UV or UX 201A Power Mogul (1)
LS	Burns Loudspeaker
HW	Belden Hookup Wire 30 feet
HW	Hookup wire 6 lengths bus bar
BP	XL Push Posts
Miscellaneous	
Two 45 volt Ray-o-Vac B Batteries	
One 4 1-2 volt Ray-o-Vac C Battery	
One World 6 volt Storage A battery	
1 Loudspeaker plug	
1 Headset	
Antenna Equipment	
Mounting screws, tools, solder, etc.	
Note: If you intend to make changes in the above requisition it would be well to write the technical staff before doing so. Some of the essentials such as coils, condensers, tubes, amplifying transformers resistances and loudspeaker MUST NOT BE SUBSTITUTED for best results.	

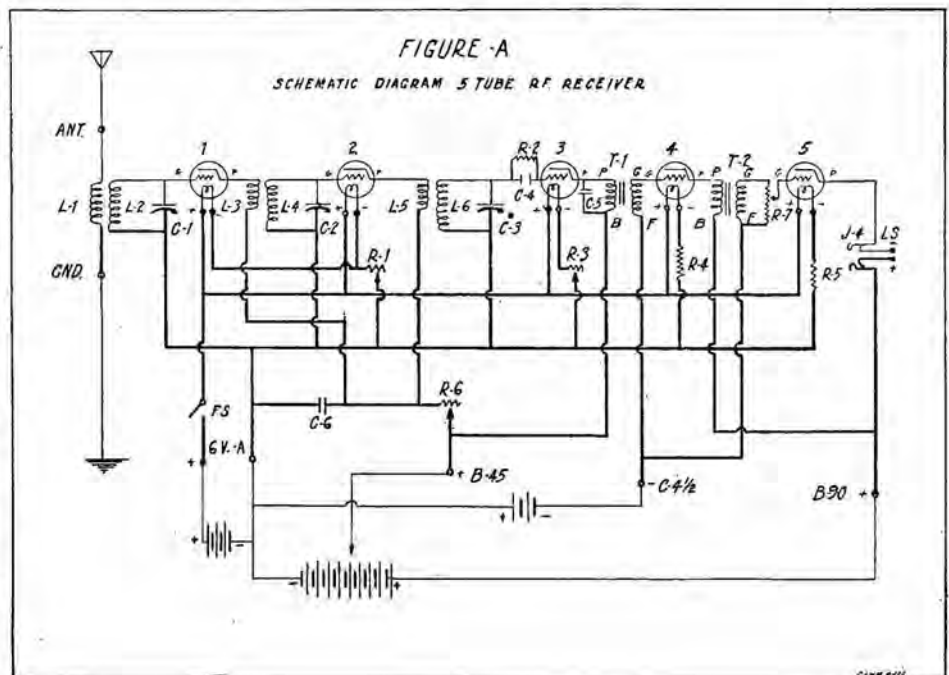

Increase the life of your Tubes by

TUBE RE-ACTIVATION

RADIO tubes, like some of the older humans, eventually lose their "pep" under the strain of constant work and require a rest or, need to be rejuvenated. This rejuvenating process, as applied to vacuum tubes, is not as serious an operation, however, as the one some humans undergo in the search for youth.

It is known as "reactivation" and is said by the Bureau of Standards radio experts to renew the sensitivity of electron tubes of the thoriated-tungsten filament type.

Concerning this method of reactivation, the Bureau has issued the following report, so skilled listeners can "pep up" their tubes themselves:

"Electron tubes in radio receiving sets eventually lose their sensitivity. This sometimes progresses to the point where the receiving set operates very poorly or not at all, even though the tube filament is not burned out. The user of the set frequently confuses this condition with that due to an exhausted B battery. If the tubes are of the thoriated tungsten (X-L) filament type, they can usually be rejuvenated by a simple process, and made to serve as well as new tubes in the receiving set.

WD Tubes Not "Renewable"

IT happens that most of the tubes now used are of the thoriated tungsten type, and it therefore becomes of quite general interest for the public to know how to secure the full life of their electron tubes. The WD-11 and WD-12 type of tubes are the only ones which can not be reactivated. In these tubes the source of the electrons is a coating of certain oxides on the surface of the filament, and when this has been used up no process can renew it.

The thoriated tungsten filaments, however, used in most of the various other types of tubes, contain the oxide of thorium throughout the whole mass of the tungsten filament, this oxide having been originally put in incandescent lamps to keep the filaments from being too fragile. The filaments are given a treatment which produces a layer of atoms of thorium on the surface of the tungsten, and this thorium, which is radioactive, emits electrons much more copiously than the tungsten would. After long use, or after burning the filament too brightly, the layer of thorium atoms is evaporated off, and so

By RADIO OPERATOR

3 9 7 3 6

few electrons are then emitted that the tube does not function properly. Reactivation is a process which boils additional thorium atoms out of the interior of the tungsten filament and forms a new layer of thorium atoms on the surface.



Figure 1. A Commercial type of tube reactivator designed for home use in dwellings where AC power is available.

The thoriated filament was developed by the General Electric Co., which has also developed the methods of reactivating tubes of this type. The Bureau of Standards has found that the reactivation process is quite successful, and frequently makes a wonderful difference in the results obtained with a receiving set. The process is essentially the operation of the filament for a very brief interval at a specified high voltage (called "flashing"), followed by a lower voltage for a longer time (called "aging"), all of this with no grid or plate voltage. The flashing reduces some of the thorium oxide in the wire to thorium, and the aging forms the required surface layer. The following schedule of these operations is the result of extensive experience of the Radio Corporation of America, and is published here by courtesy of that company:

FLASHING

Radiotron	Filament Vltg.	Time
UX and UV-199.....	10 Volts	30 Sec.
UX and UV-201-A	15 Volts	1 Min.
UX-120.....	10 Volts	1 Min.

AGING

Radiotron	Filament Vltg.	Time
UX and UV-199.....	4.5 Volts	10 Min.
UX and UV-201-A	7.5 Volts	10 Min.
UX-120.....	4.5 Volts	10 Min.

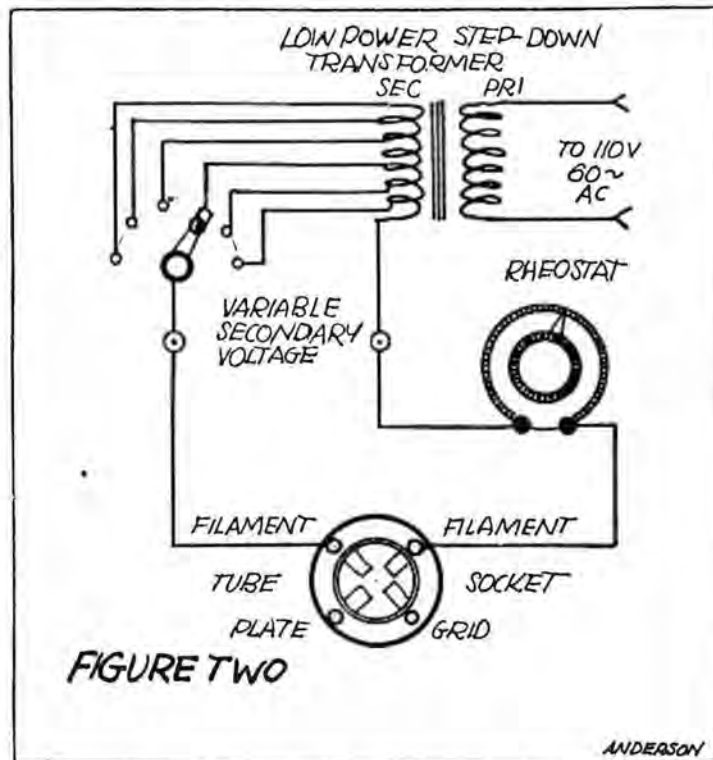

FIGURE TWO

Figure 2. This is the diagram of the home-brew tube reactivator which can be made using Junior's toy transformer that runs his electric train. A voltmeter of the alternating current type should be connected across the socket posts marked Filament.

Exactly the same procedures apply for C and CX tubes as for the UX tubes of corresponding number; thus, C and CX-299 correspond to U and UX-199; C and CX-301-A to U and UX-201-A; and CX-220 to UX-120.

In carrying out this schedule it is absolutely essential to have a voltmeter of a good degree of accuracy and to use a watch. No grid or plate voltages are used. Either alternating or direct current may be used for heating the filaments.

It is important that reactivation not be attempted until the tube user has assured himself that the tubes actually need this treatment; that is, he should make certain that his batteries are not run down, and that other parts of the receiving set are in proper order. The schedule above should be followed with great care.

Simple Apparatus Used

The apparatus necessary for carrying out the process is simple. The filament is connected to the necessary (Please turn to page 46)

RADIO CURRENT FROM THE LIGHTING MAINS

Amos J. Strong Discusses

B-Eliminator Systems

Primarily, a power current supply system is to provide a dependable source of current of unvarying voltage for the tubes of the radio receiver. The cost of the equipment is a secondary consideration. With the unvarying potential of the so-called battery eliminator comes improved performance, freedom from worry, and an increased pleasure in the possession of the set. True, the battery eliminator will save its cost in a short time if the receiver is used daily for several hours at a stretch, but this saving is not the principal objective. If radio is to provide a means of pleasure and recreation, then the battery eliminator enables the user to develop the full degree of satisfaction for which he should be prepared to pay the price.

Of all the annoying and embarrassing troubles to which a radio receiver is heir, a run-down battery takes the first place on the list. Just about the time that a demonstration of a set is to be pulled off the chances will be ten to one that either the "A" or "B" battery are down with the accompaniment of reduced volume and weird scratching noises that disguise the real merits of the receiver. While the battery condition may often prove a convenient alibi for indifferent performance, yet it is a great deal more satisfactory to have a source of power that will get more kick out of the set and thus gain better performance by steadier filament emission and higher plate potentials.

The general desirability of a power current supply increases as the number of tubes is increased; with from five to eight tubes there is a tremendous drain on the battery which calls for continual recharging or replacement of the cells. Any receiver having three tubes or more makes the consideration of an eliminator advisable regardless of the type of tube employed. Sets that pull from 15 to 45 milliamperes from the "B" battery must have an eliminator or a storage "B" battery to increase the reliability of operation and to reduce the cost. Taking another slant at the proposition in a reverse sense makes it clear that the elimi-

nator permits us to use the more satisfactory 201A tubes in place of the "199" tubes so frequently employed in six and eight tube receivers thus gaining a further increase in volume and distance, for when the current is taken from the lighting mains we need not worry how much current is used.

Lighting current consumption has been the basis of much argument among prospective purchasers of eliminators, but it has been my experience that the majority of good "B" eliminators take such a small amount of current from the mains that they seldom turn the meter at all. Without the meter running, of course the operating expense is nil. On the other hand, battery chargers take an appreciable amount of current when the battery is being charged so that from this standpoint the "B" eliminator is the least expensive.

Still another advantage of the eliminator is in evidence when we consider the use of the new UX-120 and the UX-112 amplifying tubes or the 135 volt tubes of equivalent type. Instead of replacing two 45 blocks of "B" battery at given intervals we now have to replace three blocks with a corresponding increase in the operating cost. These new tubes take twice as much filament current as the standard tubes, and we have a further drain on the "A" battery. With the eliminator, the full 135 volts can be obtained with no additional cost and the full benefits of the new power tubes can therefore be realized.

Every "B" battery, either of the storage or dry cell type, consists of a great number of small cells connected in series, and this connection of course introduces a considerable resistance into the circuit even when the dry cells are new. When partly exhausted or dried up with age, this resistance increases tremendously and cuts down the flow of current to the plates of the tube to the point where the volume is seriously affected. To some extent, this can be reduced by the use of 1.0 m.f. or 2.0 m.f. bypass condensers across the battery which reduce the resistance to the radio frequency component, but as these condensers afford no assistance in reducing the opposition to the direct battery current or to audio frequency waves, they are far from being adequate.

Voltage Drop in Plate Line

According to Ohm's Law, the drop of voltage taking place across a resistance is proportional to the amount of current flowing in amperes or milliamperes; hence when a heavy current is being drawn from a high resistance "B" battery there is a considerable drop in the plate voltage which in turn reduces the amplification and volume. This is not very noticeable with a single tube receiver but with from four to eight tubes drawing up to 50 milliamperes, the voltage drop may amount to 50 percent or even more according to the condition of the battery electrolyte. The fact that the batteries may show a full 80 volts with a high resistance voltmeter does not necessarily mean that this voltage will be maintained when the tubes are drawing a heavier current than taken by the voltmeter, hence such readings are often very misleading unless read with the set in full operation.

It is quite mystifying to take a voltmeter reading and then to find that the set will still not come up to normal volume (due to the drop in the batteries). Of course, the tubes generally get blamed for this battery defect and the cost of battery operation gets another boost when new tubes are purchased to remedy a defect due to the cells

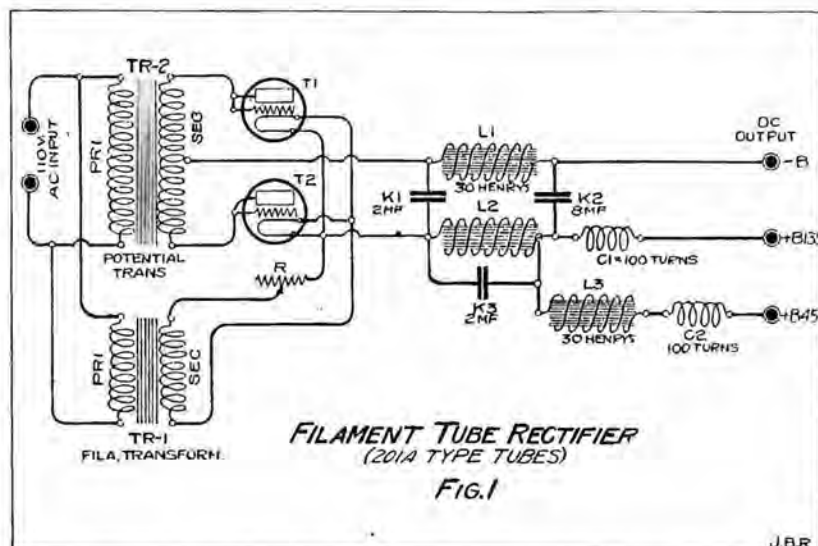

The above diagram shows the connections of the B-eliminator system using a standard receiving tube as the rectifier. This arrangement uses a special filament transformer.

It is a revelation to disconnect a set from the "B" batteries and to place it in circuit with a properly designed "B" eliminator that maintains the full rated voltage. The volume increase is terrific, the selectivity is improved because of the higher voltage on the detector tube, and distant stations that were barely audible with the batteries come roaring in almost like locals did on the batteries. A good make of eliminator will maintain the voltage within a very few percent regardless of the amount of current drawn.

"A" Battery Eliminators

AN "A" eliminator provides current for heating the filaments and takes the place of the storage battery used with power tubes or the No. 6 dry cells employed with the "199" or "WD-12" type. As it maintains a constant voltage on the filaments without attention, the rheostats seldom need readjustment and one troublesome control is thereby removed. The rheostats are primarily for the purpose of maintaining a constant voltage across the filaments of the tubes when the voltage of the battery drops during discharge, but as there is no such drop with an eliminator it is obvious that one setting of the rheostat dials is all that is required except possibly, for one critical tube. Instead of maintaining a six volt battery for the operation of a 201A tube which requires only five volts across the filament, the better eliminators supply a voltage only slightly in excess of five volts, say about 5.4 or 5.5 volts to allow for the drop in the wiring. There is now no danger of injuring the filaments by careless rheostat adjustments as is the case with battery operation.

In homes where the receiver is used by all members of the family, and generally without regard to the filament adjustment, it will be found that the 5.4 volt "A" eliminator will effect a real economy in tubes. Again, the adequate plate voltage supplied by the "B" eliminator makes it unnecessary to turn the filaments up to a vaporizing temperature to obtain the requisite speaker volume as with the batteries.

The "B" Eliminator System

For clean and noiseless reception a perfectly smooth and uniform supply of direct current must be supplied to the plate. Because of the great sensitivity of the tubes, the slightest ripple or fluctuation of the current will cause disagreeable noises or distortion. Just such a current is provided by the chemical "B" battery when in proper condition, and this is the principal merit of the battery, but the same results can be obtained by other methods from

lighting current by the employment of a proper "filter system" in the circuit which smooths out momentary variations in voltage. The filter system of a "B" eliminator is one of the most important factors and can be obtained satisfactorily by proper design.

Direct current (D. C.) lighting systems cannot be connected straight to the receiver without the intervention of some sort of filter system as such current is never perfectly smooth. Minute variations are caused by the generator commutators, by switching light and motor loads on and off, or by the commutators of motors drawing their supply from the line.

employed in the eliminator can be considered as a sort of electrical flywheel which absorbs excessive voltages and then delivers this stored energy to the tubes when the line voltage drops slightly. Further, it introduces losses into the circuit which damp down any tendency toward circuit oscillation or oscillating currents just as a mechanical friction damps down the oscillations of swinging parts.

When current is taken from an alternating current (A. C.) supply additional equipment must be provided in the eliminator for converting the alternating current into direct or continuous current before it passes through the filter. A

device of this sort is known as a "Rectifier" and is basically similar to the rectifiers used in charging storage batteries from alternating current supply. Electrically, the rectifier consists of a transformer for obtaining the proper voltage from the line, and some sort of rectifying vacuum tube for stopping the alternate waves. In effect, the rectifier tube is an electrical check valve which permits the current to flow through it in only one direction. Other means of rectification, such as an electrolytic rectifier, have also been used to a limited extent, but are so seldom encountered

in commercial eliminators that we can give them only passing notice.

In using an alternating current supply the operation is performed according to the following sequence. First, the current passes through a small transformer by which the line voltage is raised or lowered to the required voltage at the plates of the receiver tubes. Second, the A. C. current is rectified or converted into direct or uni-directional current by the rectifying tube or cells, and third, the rectified current is smoothed out by the filter system. The filtered output now goes to the receiver just as a "B" battery is connected. With all adjustments perfected, there will be an entire absence of the "60 cycle hum" or growl that would be strongly in evidence if the tubes were connected directly to the alternating current mains.

In "single-wave rectification" only half of the total A. C. waves are used, the rectifier stopping alternate waves of opposite polarity so that only half the energy is available. Such systems are more difficult to filter than the "double-wave" rectified current owing to the greater space of time between impulses. In "double-wave rectification," the reverse waves are not only stopped but are actually turned around so that they will pass through the circuit in the proper direction. We now have only a slight intermission between impulses and it is possible to gain better results although the system may be a

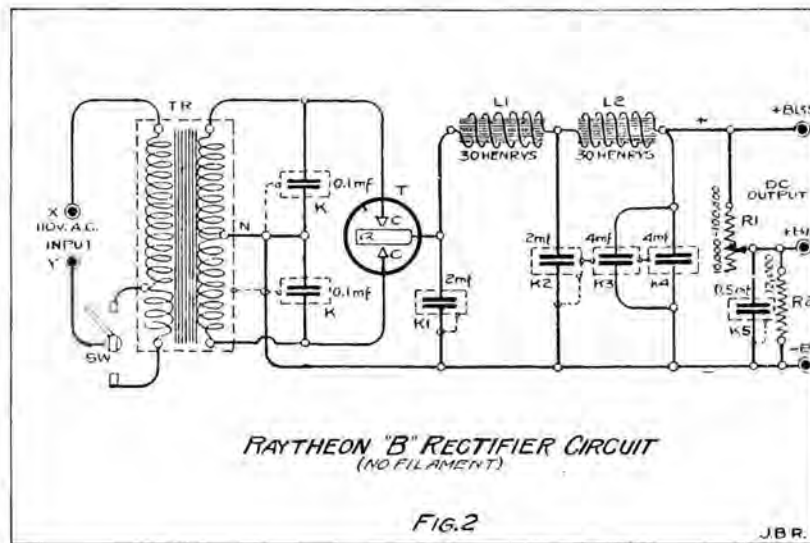

The more popular and efficient system of AC rectification for B current is illustrated above. It uses the Raytheon or Epom tube as a rectifier.



A closeup of the tube that acts as a check valve on the pulsations in the AC current of your light socket.

While these variations are small yet they are sufficient to cause heavy roaring and humming noises in the receiver unless a heavy storage battery is connected across the line to absorb the fluctuations and to maintain a more constant potential. The filter system em-

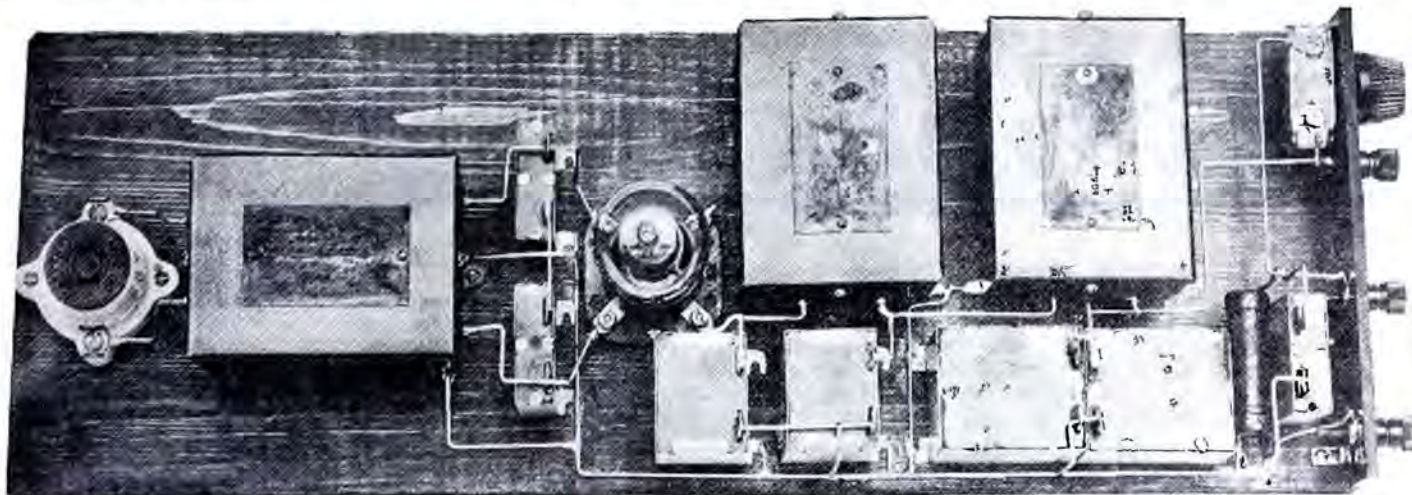

Figure 4. How the finished B Eliminator looks. This is the Gaseous Tube Rectifier type using either the Raytheon or Epom tube.

trifle more expensive. The double-wave rectifier is superior to the single-wave type for exactly the same reason that a six cylinder car is smoother running than a one or two cylinder car.

The Filter System

A FILTER contains at least one iron core inductance or choke coil and two or more large fixed condensers. The choke, which ranges from a value of 30 to 50 henrys consists of many hundreds of turns of fine wire around a laminated steel core, and in appearance is much like an audio transformer. It chokes back pulsations and variations in the rectified current and supplies the necessary electrical inertia to carry the circuit over the period when the impressed voltage is below normal. The fixed condensers placed at the ends of the choke coil transfer impulses from the opposite side of the circuit to oppose current fluctuations passing through the opposite choke coil. This helps in smoothing out the current, and in addition absorbs any oscillations that might take place. These condensers are quite large and have capacities ranging from 2.0 to 8.0 microfarads each, or often a total of 30 microfarads in the complete circuit. The condensers are the most expensive part of the equipment, and it is here that the skimping and squeezing is made by the majority of the manufacturers.

If the condensers are not of sufficient capacity, there will be noise and distortion. With small condensers the lower notes of the musical scale will not pass through the eliminator and the tone will suffer and be flattened out accordingly. Particular care should be taken to have the condenser capacity great enough on the output ends of the chokes.

All the metal cases of the condensers, chokes and transformer should be grounded to the (-B) side of the D. C. line, but not connected to earth.

Filament Tube Circuit

Filament tubes of the 201A type are very frequently used as rectifiers or the special filament type rectifying tubes can be installed when the current demand is greater than 40 milliamperes. When the 201A tubes are used in this way the plate and grid terminals of the socket are connected together to form one pole while either

side of the filament is used as the other side of the circuit. The principal objection to filament rectifiers is the fact that there is always some slip-back or imperfect rectification and that the filaments eventually become exhausted or burn out. However, if the proper filter system is used a very smooth D. C. current can be obtained with two tubes acting as full wave rectifiers.

Fig. 1 is a schematic diagram of the full-wave type of filament tube rectifying circuit with the accompanying filter system. Here we have the two tubes (T1) and (T2) supplied with filament current by the transformer (TR-1). As will be seen, the grids and plates of the tubes are connected together, and are then connected across the outer terminals of the potential transformer (TR-2) which supplies the necessary voltage for the plate circuit, or rather twice the desired voltage when measured across the ends of the transformer (TR-2). A rheostat (R) is used for the control of the filament heating. Usually, both transformers are enclosed in a single magnetic circuit, but in the diagram the two elements are shown separately for simplicity in explanation.

At the right of the tubes are the two chokes (L1) and (L2) by-passed by the fixed condensers (K1) and (K2), while a third bypass (K3) is connected across (L2). This, together with the radio frequency air-core choke (C1) constitutes the 100 volt portion of the filter circuit used for the audio frequency transformers. A third iron core choke (L3) and a second radio frequency choke (C2) are inserted for the 40 volt tap to the detector or radio frequency stages. Connections to the radio receiving set are made at (-B), (+B45) and (+B135).

Raytheon or Epom Tube Circuit

TWO new rectifying tubes without filaments, the Raytheon and the Epom, afford a number of advantages over the filament tube. In the first place, there are no filaments to depreciate hence they have an indefinitely long life, and again only one tube is

necessary for full wave rectification instead of the two tubes necessary with the filament tubes.

The Raytheon and Epom tubes operate on the principle of gaseous ionization which is too lengthy a subject to deal with in this article. It contains an "anode" or positive cup and two cathode or negative electrodes terminating just under the cup. The two cathodes are connected to the ends of the potential transformer while a lead from the anode leads straight out to the chokes on the positive (+B90) side of the D. C. line. The negative D. C. line is tapped at the center point of the transformer secondary. As with the filament tubes, the grid and plate terminals of the socket are connected together.

Fig. 2 shows the Raytheon or Epom circuit with the tube at (T). In this tube (a) is the anode cup while (c-c) are the two cathodes shown in diagrammatic form. The two condensers (K) are the starting condensers for the tube while (TR) is the potential transformer. The negative line is connected to the center point of the transformer secondary at (N). This completes the input end of the circuit, except for the double throw switch (SW) which permits of two voltage ratios with the transformer.

Iron core chokes, (L1) and (L2) rated at 30 henrys are connected to the anode (a) and form a part of the filter system. The fixed condensers (K1-K2-K3) across the ends of the choke are also a part of the main filter system and act in combination with the iron core chokes. At (K4) is an additional output condenser of sufficient capacity to pass the low audio frequency components. The full potential for the audio circuit of the receiver (135 volts) is taken from the tap (N) ending in (-B) and the positive connection (+B 135). The two resistances, (R1) and (R2) form a potentiometer arrangement by which the intermediate 45 volt lead for the detector and radio frequency tubes is taken off, and the resistance (R1) is made adjustable so that this voltage can be regulated. Condenser (K5) bypasses the resistance (R2). These resistances also have a considerable damping effect in addition to their potentiometer function so that any ripples escaping from the main filter are killed in the resistance stages

Feedbacks

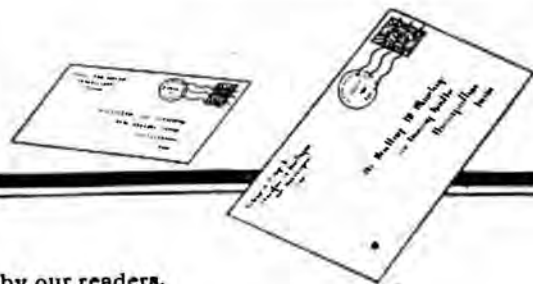

This department is composed of contributions by our readers, and ON THE AIR assumes no responsibility for statements made by such contributors. It is a department where readers may discuss and submit ideas, achievements, kinks and experiences for the mutual benefit of all enthusiasts.

WE'RE not going to steal any of your valuable space by opening with a long editorial so here's off to a flying start.

Carl Uhl of 200 East Crane St., Topeka, Kansas, writes us and describes some of his experiments with the Roberts Reflex and the Browning-Drake circuits. He talks about selectivity and says that he feels that some of the Chicago boys are exaggerating just a little when they claim to be able to separate Chicago stations and get through DX. He admits that he has trouble way out there in Kansas even though he does own a set that is sharp in tuning. To quote him, "I'll bet that it is done, but not as a

that he would have gotten a good many more, only it gets difficult to keep from duplicating receptions after you have tuned for more than two hours.

Carl encloses some suggestions for neutralizing the Browning-Drake circuit (or any other circuit for that matter) which we are printing in Figure 1. He also says that the method shown in Figure 2 will give greater selectivity with the Browning-Drake circuit if followed out carefully. If you have any trouble in doping out the details drop him a line. Don't fail to accord him the courtesy of a stamped addressed envelope if you want an answer.

ought to see his letter. WOW!

Here's a letter from a Wisconsin fan who likes neutrodyne. He has good reason for liking them as his letter will testify:

Feedbacks Department.
GENTLEMEN:

I have read the last three issues of "On the Air" and to say I enjoy it is putting it mild. The real friendly way the articles are written is so different from the many cut-and-dried articles of so many other magazines.

I always like to read "Feedbacks" and after reading over the January issue I just have to write and let you know that

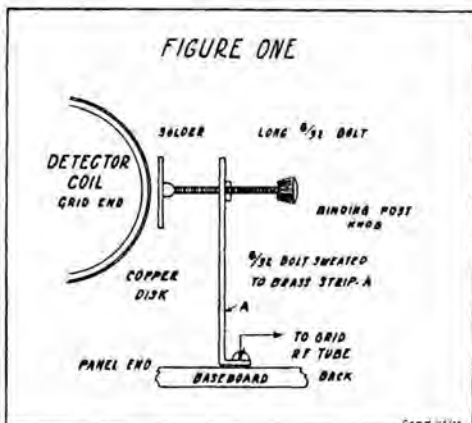

John A. Coleman of Murray, Iowa, writes in and says he thinks a good non-regenerative set beats a crystal set all hollow for tone. He says that he bases his contention on the fact that the crystal passes the strongest current, and that the static is usually the weaker. He also says he wonders which is the most effective; regeneration in the detector stage or in the RF stage in a four tube 1RF, detector and 2 AF receiver. What do you think?

Edward C. Roberts of Port Byron, N. Y., writes in and tells "Larry" of last month's issue all about the care and maintenance of the storage B's that Larry had so much trouble with. You

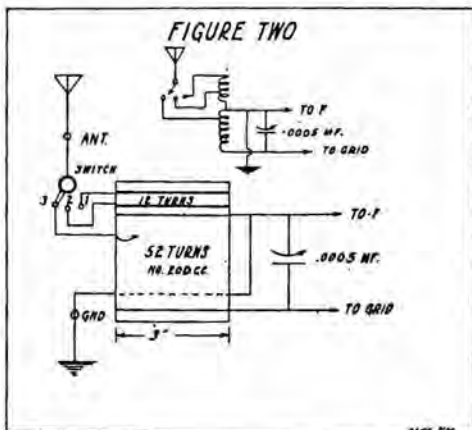

The above is an interesting and effective method to use in neutralizing an RF stage. Adjustment is accomplished by screwing the copper disk close to the windings of the coil.

regular thing" he says. "Some nights there are any amount of stations over 500 miles away that are difficult to separate." This is dependent on atmospheric conditions, I think, as on other nights I have no trouble in separating KOA, WSAI and WJAZ."

He sends in an excellent log of 57 stations heard between 5 p. m. and 1 a. m. CST. The list includes 5 California stations and says

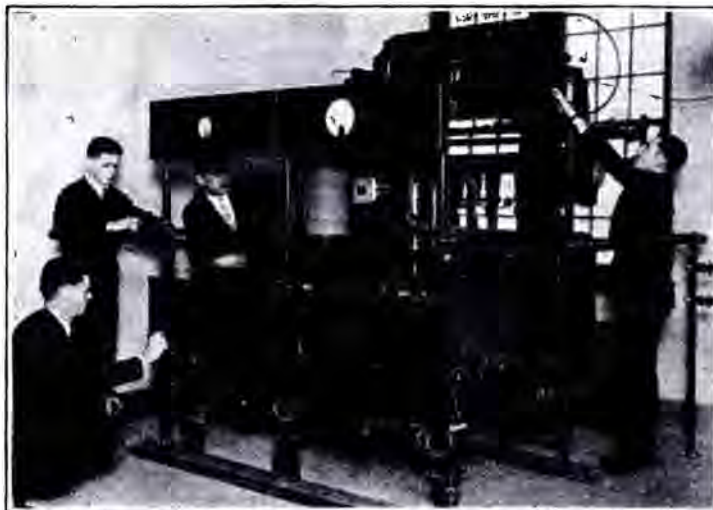

THE WORLD'S LARGEST BROADCASTER

A closeup view of one of the huge oscillators of the new 50,000 watt transmitter of WJZ located at Bound Brook, N. J. Compare this huge generator of radio frequency signals with that on page 48.

Many fans have been asking for an effective method to sharpen the tuning of the Browning-Drake set. This is what one of our readers did to accomplish the trick. It is applicable to any set using a directly coupled antenna.

the Neutrodyne fans are still alive.

Below is a list of stations heard one Monday night (to be exact Monday, Jan. 4) on the loud speaker:

- KFIZ, WREO, WSB, KFAB, WMBF
- KDKA, WSMB, WFBM, WSM, WRR,
- WGHB, WPG, WAIU, WHN, KV00,
- WDAF, WFAA, WHBF, KSO, WJBC,
- WEAF, WOAW, WCCO, WJZ, WHAZ
- KTHS, KFKX, KOIL, KMA, WSOE,
- WCLO, WOWO, WSAI, WJAD, WTAM,
- WJR, WKRC, WADC, WWAE, WDAD,
- WHO, KFI, WJBL, KGO, WAMD.

Besides these I heard 6 Chicago stations when (Turn to page 48)

Comparing AUDIO AMPLIFIERS

GLENN H. BROWNING

tells how different systems compare in laboratory tests

EVERYONE building a radio set wants to hear exact reproduction of the speech or music transmitted by the radio casting station, yet many sets simply give noise which makes the best artist sound very mediocre. The question of the quality, i. e., the naturalness of the sound emitted from the loud speaker is therefore of paramount importance. The novelty of radio is wearing off, and the public is demanding good quality rather than great distance. Who listens to a program sent out from a station 3000

and transformers. In order to compare the various methods, let us take up each of these systems independently, giving the advantages and disadvantages of each.

Two Stage Transformer Coupled

Advantages: 1. Ease of construction. 2. Only two tubes and two transformers necessary. 3. Gives ample volume for loud speaker reception.

Disadvantages: 1. Poorer tone quality than other

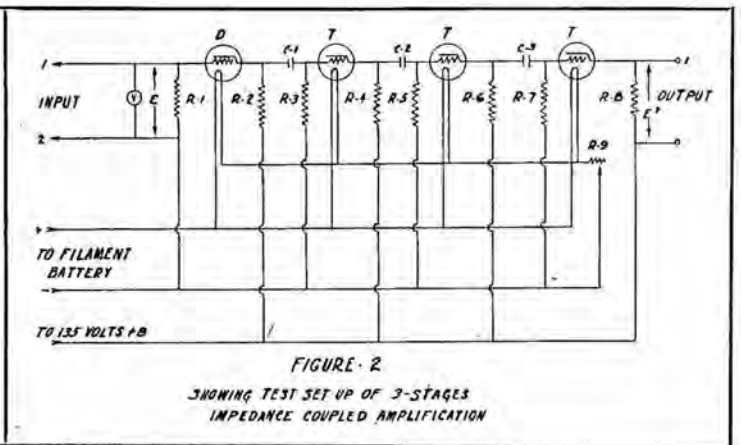
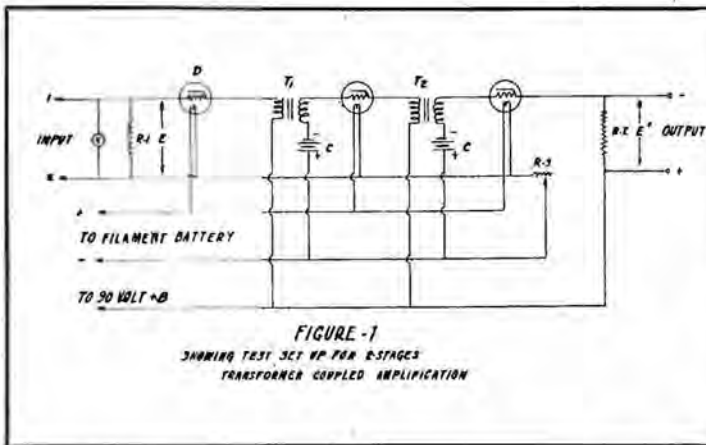

This is the laboratory setup used in the tests to determine the efficiency of the standard transformer coupled amplifier.

miles away, and really enjoys the music? The thrill comes from being able to span those thousand miles and say that you have received 2LO London or KGO Oakland.

Every part of the receiver from the detector to the loud speaker distorts the signals somewhat, but the audio amplifier consisting of transformers and vacuum tubes is probably the most serious offender. Of course, audio transformers have been greatly improved, but there is still room for improvement in this type of audio amplifier.

Resistance vs Impedance Coupling

ATTENTION has been called to fact that the resistance coupled amplifier gives almost perfect reproduction, justifying the popularity of this type amplifier. However, an impedance coupled amplifier correctly designed and built, also gives almost perfect reproduction and has some advantages over resistance

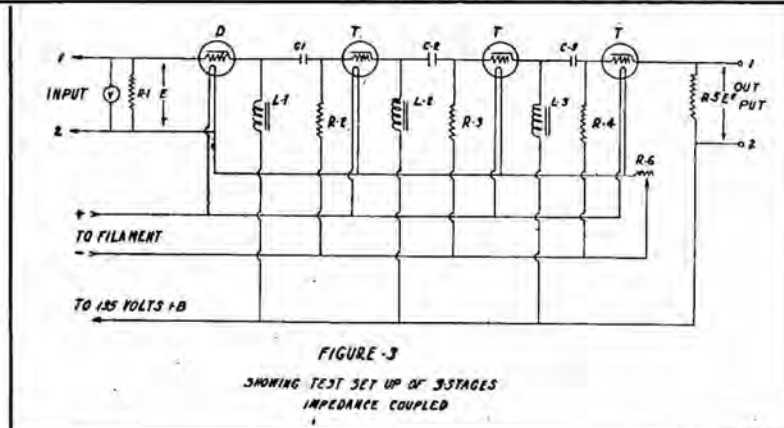

The impedance coupled amplification arrangement shown above is the system Mr. Browning is partial to because it incorporates all the advantages of the ideal amplifier with the fewest limitations.

In each case the signal from the laboratory oscillator was measured at E of the input, and then at E' the output at various frequencies.

two systems. 2. Tendency of feed back which causes continuous howl.

Three Stage Resistance Amplifier

Advantages: 1. Almost perfect tone quality. 2. Very little tendency for howling.

Disadvantages: 1.

Plate or B battery of at least 135, volts necessary. 2. Three tubes used. 3. A little less volume than two transformers.

Three Stage Impedance Amplifier

Advantages: 1. Only 90 volts B battery necessary. 2. More volume with three tubes than with resistance. 3. Almost perfect tone quality.

Disadvantages: 1. Three tubes necessary. 2. Volume with three tubes a little less than two transformers, but considerably more than three stages of resistance.

Using three vacuum tubes instead of two for our amplifier is no longer as serious a draw-back as it was a

few years ago when tubes sold for \$6.50 each, so that more impedance and resistance amplifiers are being used every day. The fact that measurements show that two transformers give more volume than the other two systems is somewhat misleading due to the fact that the low tones do not come through as well with a transformer as they do with resistance and impedance. As a large percentage of the energy of speech and music is carried in the low tones, the volume seems to be considerably more with the latter two systems than would be indicated by observing the curves on the system.

What Laboratory Tests Show

TO OBTAIN exact data on any system, laboratory measurements should be resorted to as well as the ordinary practical tests. To this end the systems shown in Fig. 1, 2 and 3 were set up and the voltage amplification of the three systems obtained by measuring the input (e) and output (e') by means of a vacuum tube voltmeter and a Rawson thermal voltmeter. These measurements were taken with different frequencies ranging from 100 to 10,000 cycles a second, impressed from a Western Electric audio oscillator, and gave the amount of amplification at each frequency. Instead of using a loud speaker in the output at the last tube, a resistance equal to the tube resistance was substituted—the reason for this being that the impedance of a loud speaker would vary with frequency. In practice the first tube shown in the diagrams as D would be the detector tube of the receiver, so that its effect was subtracted from the over-all amplification. The resultant curve is shown in Fig. 4.

This chart of voltage amplification against frequency gives a very good idea of tone quality and amplification of the three systems discussed.

Curve A was taken with the system shown in Fig. 3 (impedance coupled amplifier) with a power tube in the last stage and two Mu 20 tubes in the two preceding stages. Curve B was taken with the same tubes used in the circuit shown in Fig. 2 (resistance coupled amplifier). Curve C was taken with 201A tubes used with the system shown in Fig. 1 (transformer coupled amplifier). Curve D was obtained with 201A tubes used with the impedance coupled amplifier, while Curve E was obtained with 201A tubes in the resistance coupled amplifier.

In interpreting the curves, it should be understood that the more constant the amplification is from 100 to 10,000 cycles per second, the better the tone quality of signals received. Thus, resistance and impedance would seem to give perfect reproduction while the two transformers would accentuate the higher tones at

the expense of the lower ones. In actual practice the difference in volume between the systems is not so great as would be expected from the height of the curves, for two reasons. First, as has been stated, the lower tones carry most of the sound energy, and second, the human ear is very insensitive to changes of intensity of say two to one, unless the incoming signal is extremely weak and near the threshold of audibility.

To sum up the situation, it might be stated that each of the amplifiers give sufficient volume for loud speaker reception, if the radio receiver is at all sensitive, that the resistance and impedance systems give almost perfect tone quality, and that the choice between those two lie in the fact that impedance gives more volume with less B battery voltage than resistance.

Among all the technical arts, radio has given the greatest opportunity to the inventor. Each branch of engineering art has had its own eminent specialists who have created most of the new things that has been done in those arts, but radio has become a playground for all. It seems to be the favorite child of all the other technical arts and sciences, a meeting ground for exchange of mutual inspiration. In the assembly here today, we see at least three generations of radio inventors. First, it behooves those of us who are of the second and third generations to pay tribute to those who gave us our original inspiration.

A new field of human endeavor has now been created. The originators were the most advanced thinkers in physical science and electrical engineering. But the most significant fact is the unprecedented rapidity with which this new knowledge has spread. In the now growing generation almost every high school boy has,

thanks to the popularity of radio, some intimate knowledge of a complicated art which not long ago could be grasped only by very few.

As our civilization marches forward it makes inventions with an inevitable necessity. Inventors by habit and profession are simply the scouts who march ahead and become aware of new technical developments somewhat ahead of the multitude. A new event is usually seen by several of these scouts at nearly the same time. But these scouts are becoming more and more specialized and they are able to discern new phenomena only within the limited

sphere in which they have been trained. The necessary training is in most cases an opportunity which has come only to a few among the many who might have accomplished the same.

If we should project into the future the growth of the electrical arts and sciences we can see the young art of radio growing up and taking a central position.

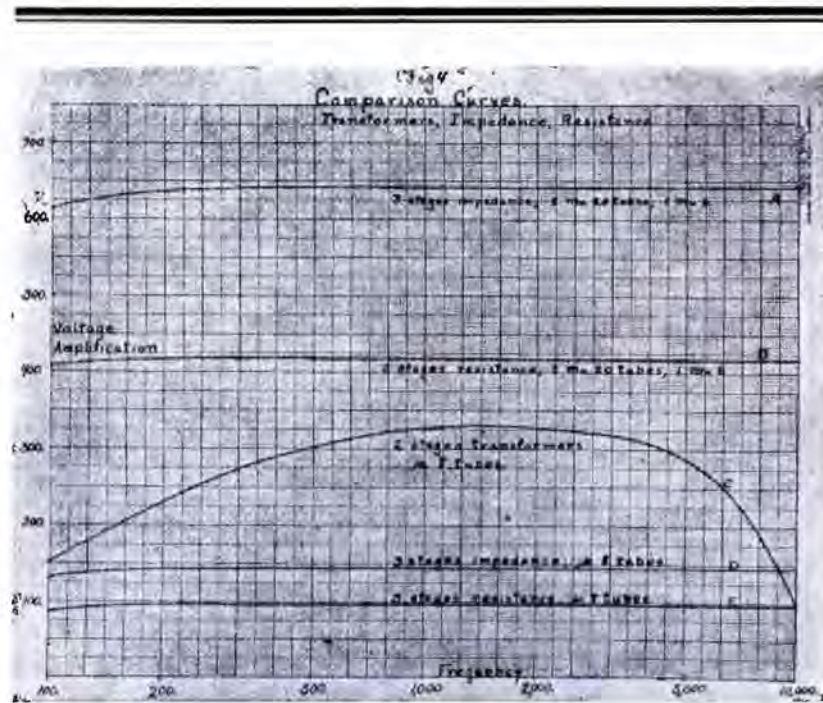

How the amplifiers stack up against each other on paper. The chart shows the voltage amplification at various frequencies for the three systems—transformer, impedance and resistance.



The Technical Editor to the Broadcast Listener



Telephone Interference

A. J. L. Perham, Minn.

QUESTION: I am a reader of On The Air, and have a great deal of trouble at hand. We have one of those pest Telephone Ringers in this town and it sure does its stuff when it comes to interference. Have read your article in the November of On The Air. You stated that a telephone bell ringer was a quite simple thing to do away with.

The make of the outfit we have here is a Leich Serial No. 1036 made by the Leich Electric Co. Runs off of 110 volt A. C. What is the best thing to do and where can I get these choke coils you speak of. Please give me address of company where I can get these coils made up.

ANSWER: I have been fortunate enough to locate a definite source of apparatus and equipment as well as specialized advice since writing the November article, and I take pleasure in referring you to Mr. Charles Ruge, Engineer of the Kellogg Switchboard and Supply Company of 1066 W. Adams St., Chicago, Illinois, for further data on the elimination of your interference.

I would advise that you get in touch with him direct, telling him everything you know about the ringer. This means type of current, whether it operates grounded, whether it is one of the pole harmonic types and various other specifications that usually appear on the ringer box.

LC Ratio and Loop

D. H. G., Toledo, Ohio

QUESTION: Pursuant with your suggestion of several weeks I built the Victoreen Super using impedance coupled amplification, which, after causing some trouble in balancing, has developed into the finest receiving set I have ever listened to. Amplification is as near perfect as I believe possible, and the tone "sweetest ever." Volume tremendous.

Now I have only one difficulty to overcome and I know you can help me. Used Karas Orthometric Condensers and an Aero Loop, but am unable to tune below 240 meters; even a Silver loop won't go any lower.

ANSWER: I am glad that you are getting good results with the super-

TECHNICAL INFORMATION SERVICE

ON THE AIR is inaugurating this special technical service department for the convenience of its readers in helping them to solve technical and general difficulties common to radio broadcast listening.

There is no charge for this service which is maintained by a corps of technical men, and readers who wish to avail themselves of the service need only to observe a few efficiency rules.

1. Do not ask for comparisons between products advertised in this or other journals. In justice to our advertisers, we cannot convict one product and recommend another.
2. Don't ask too many questions. Boil your letter down to just what you really need.
3. Don't ask questions that require too much research work or reference. Give the other fellow a chance.
4. A letter of inquiry written in the following form always gets a quick reply. If you would expect speed, make your inquiry conform to the requirements.
 - A. Enclose a standard business size stamped addressed envelope. No envelope, no answer. Foreign countries need no stamps.
 - B. Write, don't scrawl. Use typewriter if possible. One side of paper only.
 - C. Diagrams and drawings on separate sheets. Fasten correspondence together.
 - D. Number your questions or paragraphs, and keep the subject matter of the paragraph unified. When we answer, we'll refer to the number of the paragraph. Keep a copy of your letter for reference.
 - E. Put name and address on each sheet.
5. Address your questions to ON THE AIR Technical Editor, 1304 Kimball Hall Bldg., Chicago, Ill.

heterodyne we recommended to you. I am sure that the many other fans who are contemplating building supers will like to see this report.

The reason you can't get down to 200 meters is due to one of two things. First your loop may be too large for the condenser you are using to tune it with, or your oscillator may not be heterodyning as low as 200 meters. I would suspect the former, and advise that you try tapping your loop so that you may use fewer turns in the circuit. One or two turns less than you are using now will no doubt end your difficulty. If this does not help, I would suggest that you write the George W. Walker Company, of 6544 Carnegie Avenue, Cleveland, Ohio, telling them of your difficulty.

Rebuilding Advice

C. R. T., Memphis, Tenn.

QUESTION: I have been trying to get a good 4 tube set together for the last 4 months, and to date I have one—that gets anything on the air—all at the same time. It doesn't seem to care how the signals come in.

I have a three circuit tuner, a .0005 Mfd. G. I. Condenser, Dubilier RF transformer, 2 Hedgehog AF transformers, 1 six ohm rheostat, 4 sockets and 4 201A tubes. Any hookup you can furnish me that employs all or part of the listed parts will be very gladly welcomed.

ANSWER: In Figure 1, I am printing a circuit that can use part of the equipment you list in your letter. Directly below the circuit I am printing a legend of the parts that

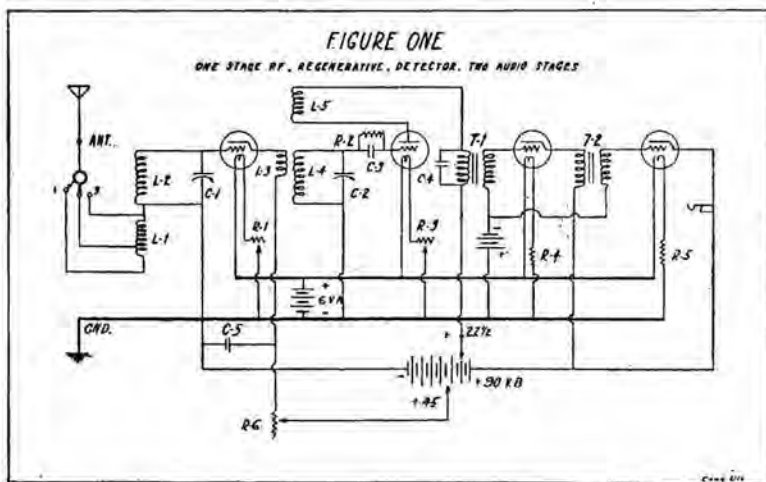

ESSENTIAL LIST OF PARTS

- L1 Antenna Coupler See page 40
- 2 Antenna Coupler See page 40
- 3 {
- 4 Three Circuit Tuner
- 5 }
- C1 .0005 Mfd Variable Condenser
- 2 .0005 Mfd Variable Condenser
- 3 .00025 Mfd Sangamo Fixed Condenser
- 4 .001 Mfd Sangamo Fixed Condenser
- 5 .5 Mfd Tobe Deutchman or Sangamo
- R1 30 Ohms rheostat Carter
- 2 3 megohm grid leak Daven
- 3 30 Ohm rheostat Carter
- 4 Amperite 1A
- 5 Amperite 1A
- 6 Centralab 200M Resistance
- T1 Audio Transformer
- 2 Audio Transformer

you may make additions to the collection you already have. The coil L1 and L2 is made according to the suggestion of one of our readers (illustrated on page 40 of this issue). It will give ample selectivity. About the only thing I have to add is that you may have to rewind the primary coil L3 of the three circuit tuner. Ten turns on this coil closely coupled to L4 is ample. If you need greater selectivity, increase the number of turns on the coil to about 15 and increase the distance between L3 and L4 to about an inch and a quarter. As the distance increases you can add turns up to about

22 where the limit comes in. Also as you increase the coupling distance between L3 and L4 you may have to increase the B voltage coming up to the coil through the resistance R6. If you need further help don't hesitate to write again.

Adding a C Battery

L. F. K., Hoopetstown, Ill.

QUESTION: I am a regular reader of your ON THE AIR magazine and to say that I like it very much is putting it mildly. I like your technical items so much that I am asking you to show me as plainly as you can how I can add a C battery to my five tube Freshman Masterpiece. I have quite a few friends who are having the same trouble as mine—that of exhausting the B batteries too quickly. Thank you in advance.

ANSWER: A number of my clientele have been asking me about this very same thing so I am printing a diagram in Figure 2 showing how it may be accomplished.

Locate the First and second audio transformers in your set. Next find the Grid return lead marked F or Fil. or Neg. Fil. Remove the wire from this connection on both transformers. Now connect the two F (grid return) posts together. Then from the most convenient F post (which you have just joined together) run a wire to the minus C connection of a C battery. The positive connection of the C battery is then connected to the two wires that you took off the F posts on the transformers. Make sure that these wires (the ones you disconnected) run to the A minus line somewhere in the set by tracing it right down to the A minus battery binding post. With 90 volts of B battery you should use a 4½ volt C bias. (Bias is the term for A battery of this type.)

Low Waves and Crystals

V. W., Racine, Wis.

QUESTION: Have built several sets described in ON THE AIR and have had good success with them. Here is something that has been bothering me for a long time.

Is there any sort of a crystal set hookup that will bring in the low wave amateur stations? If so please supply me with a diagram and any data you can on constructing a set for this type of duty.

ANSWER: Reception of amateur stations requires an oscillating detector, due to the fact that amateurs use continuous waves for transmitting. Since a crystal does not oscillate except in laboratory work it is not practical to use it. I would recommend that you build up the Super-frequency receiver described in the last issue of ON THE AIR using UV199 tubes for the work. Full details appeared in the past issue.

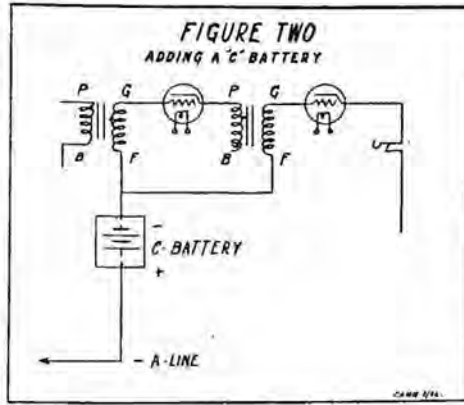

The method of adding a C battery to the audio stages is indicated in the diagram above. It is a wise addition to any set, as it represents a decided saving in B Batteries.

An All-Wave Tuner

H. M. M., Kane, Penn.

QUESTION: I have a three circuit set at present that I would like to change into an all wave receiver covering from 50 to 3600 meters. I am enclosing a list of parts that I have on hand, and would appreciate your adding to this list just such parts as I will need to complete the set.

ANSWER: In Figure 3 I am printing a diagram of a regenerative receiver that uses honeycomb coils for the tuning units. With this set you will require one of the three circuit honeycomb mountings sold by any of the big mail

- ESSENTIAL LIST OF PARTS**
- L1 } Honey comb coils Mounted
 - 2 } Honey comb coils Mounted
 - 3 } Consult catalogue of your dealer
 - C1 .001 Mfd. Keras
 - 2 .0005 Mfd. Keras
 - 3 .0025 Mfd Fixed Sangamo
 - 4 .001 Mfd Fixed Sangamo
 - RI 3 megohms Daven
 - 2 30 Ohm Carter Rheostat
 - 3 6 Ohm Carter Rheostat
 - FS Filament Switch
 - T1 Audio Transformer 2-1
 - J1 One spring jack
 - 2 Three spring jack

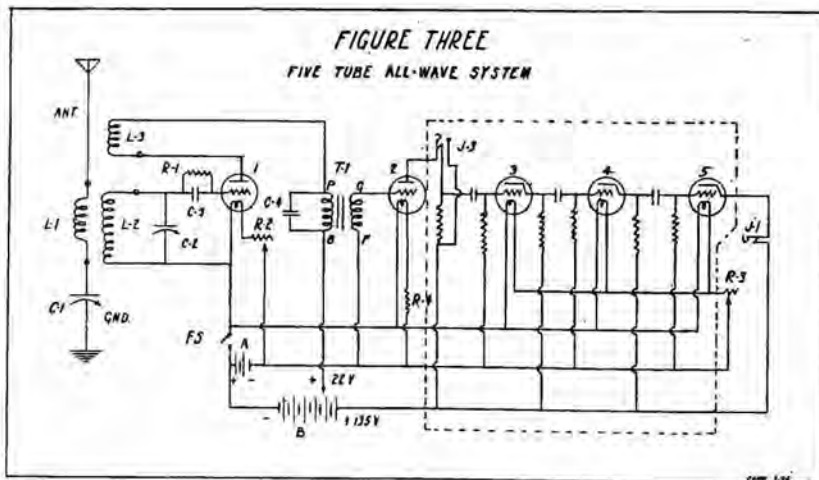

Honeycomb coils and regeneration make an excellent all wave receiver capable of tuning in over the range of from 50 to 3600 meters. The diagram shows the connections.

order houses. The catalogues issued by them give the proper sizes to cover the various wavelengths with the condensers I have indicated. It might be

a good plan to include a series parallel switch to throw the condenser C1 in series or parallel with the coil L1. The rest of the equipment is standard. In the dotted lines I am showing the resistance coupled amplifier you request, which should give you excellent quality of music on the broadcast waves. This amplifier might be one of the ready made units such as made by the Daven Company or Allen-Bradley people. It would simplify matters very greatly.

On the lower wave it might be necessary for you to wind your own coils, and in this connection I am suggesting that you experiment. It will also be necessary to use a very fine vernier dial on the condensers on lower waves due to the fact that the tuning condenser C2 is quite large for this work.

Fans Speak for Themselves at Last

THAT broadcasting is not yet perfect, seems to be the consensus of opinion of some 2800 radio fans scattered throughout 48 states. This was shown in a recent canvass by A. Atwater Kent, of Philadelphia, in an effort to learn what the average listener wants in the way of radio entertainment. Practically all listeners agreed that there are far too many small broadcasting stations operating in the lower wave band, and that there is too little high-class entertainment, although many admit that the chain broadcasters are giving excellent service.

Lack of variety in programs and poor announcing from many stations, are given as constructive criticisms by radio denizens of over five hundred cities and towns. "No, there is not too much classical music," 2400 reports out of 2600 state. On the other hand, there is too much jazz according to 1420 replies out of a total of 2534 answers. Short talks and timely speeches also appear to hold fan interest, the survey shows.

Interference from various sources is noted by over half the correspondents; only about 9 per cent of the writers claim they have no interference. Static is blamed by over 70 per cent of those having reception difficulties, and 75 per cent of them admit that their local or nearby stations come in the best. This is believed partly due to the static handicap. Code reception still causes some interference; about a third of the fans reporting interference, says this form bothers them.

A large number insist most of the interference is due chiefly to the fact that so many stations are crowded into the wave lengths between 300 and 200 meters.



Let Our Own Engineers Help You Choose a Radio!

IF YOU are contemplating buying a new radio set or new parts to build your own receiver, you will want the best for your money, or you will never be satisfied. The average fan has not the facilities or the inclination to study the peculiarities of a radio before making his decision. He takes a chance; and sometimes he is lucky, while invariably he wishes he had bought another set.

TO SERVE those readers who want expert technical counsel, ON THE AIR installed a research laboratory in its offices—the most efficiently equipped and modern radio laboratory maintained by any radio publication. A group of nationally known engineers preside over this laboratory, and their services are at the command of ON THE AIR readers, at no charge. All we ask is that you fill out the coupon on this page, indicating your needs, and by return mail will come all the information you are seeking.

ON THE AIR'S Laboratory engineers are ready to supply you with a detailed analysis of your radio problem; diagrams if you wish to build your own; recommendations, prices and other buying specifications if you wish to purchase equipment complete; or our engineers will merely give you their personal opinion of the apparatus inquired about, sending you detailed manufacturers' literature if you desire.



This Service Takes the Guesswork Out of Radio Buying!

THIS COUPON WILL HELP YOU—FREE!

Editor, On the Air,
1322 Kimball Building,
Chicago, Ill.

Dear Sir: I am interested in { radio receivers } and would like your advice on radio parts { radio parts } and would like your advice on what apparatus to choose, at no obligation to me. I am particularly interested in

.....

Note: Specify above whether you want specifications of receivers, and if so, number of tubes and circuit or diagrams for your own use. Buying specifications, prices, etc., will be furnished if desired. If detailed information is wanted use another slip of paper.

Name

Address

City State

2-26

Note:—Purely technical inquiries should be addressed to the Technical Dept. and NOT sent with this coupon

Reactivating Tubes

(Continued from page 36)

source of voltage nothing being connected to the grid and plate. A voltmeter is connected across the filament terminals. If alternating current is available the source of voltage can be a small transformer, such as those for running doorbells or electric toys. The voltage tap nearest the voltage specified should be selected and a rheostat in series with the filament used to adjust to the exact voltage. The voltmeter must be one for alternating current.

If alternating current and a transformer are not available dry batteries or storage batteries may be used as a source of voltage. A single dry cell when new will furnish approximately 1.5 volts. A rheostat should be connected in series to give the exact filament terminal voltage as indicated on a direct-current voltmeter.

A. C. Current More Effective

TESTS prove, however, that the battery method, which utilizes direct current to promote this rejuvenation, is not as effective and complete as when alternating (house current) is used. Direct current supplied by the batteries, when used to renew the tubes does not, tests indicate, give the results that alternating current can furnish. In alternating current, the current and voltage reverses and drops from maximum to zero in most cases sixty times per second. Between each reversal and rise of potential, there is a period—a fraction of a second when there is no current and no voltage flowing through the circuit; it is this advantage that the A. C. method gives. Sixty times a second, the filament, when connected to an alternating current source, is heated to a red hot temperature, and as a distinct advantage it also has a slight opportunity to cool sixty times per second likewise. It appears that this pulsating nature of the current favors the rearrangement of the electrons of the filament, and produces at the end of the rejuvenating process a greater number of thorium atoms on the surface of the filament wire. This is exactly what we seek,

Renewing Process Repeatable

This renewing process can be repeated many times before the tube shows a drop in efficiency, provided it is intelligently done. In tests made for the purpose of determining the effective length of the life of radio tubes, rejuvenation has been repeated as high as sixty or seventy times without the tube showing any marked drop in effectiveness. The curves shown

in Figure 3 give an idea of what the practical value of such "renewing" is. Curve A represents the normal efficiency of a new tube. Curve B was taken after the tube had been rejuvenated thirty times, with a loss of only 12% in efficiency. Under the direct current method this value would have been considerably lower. The real test is shown in the

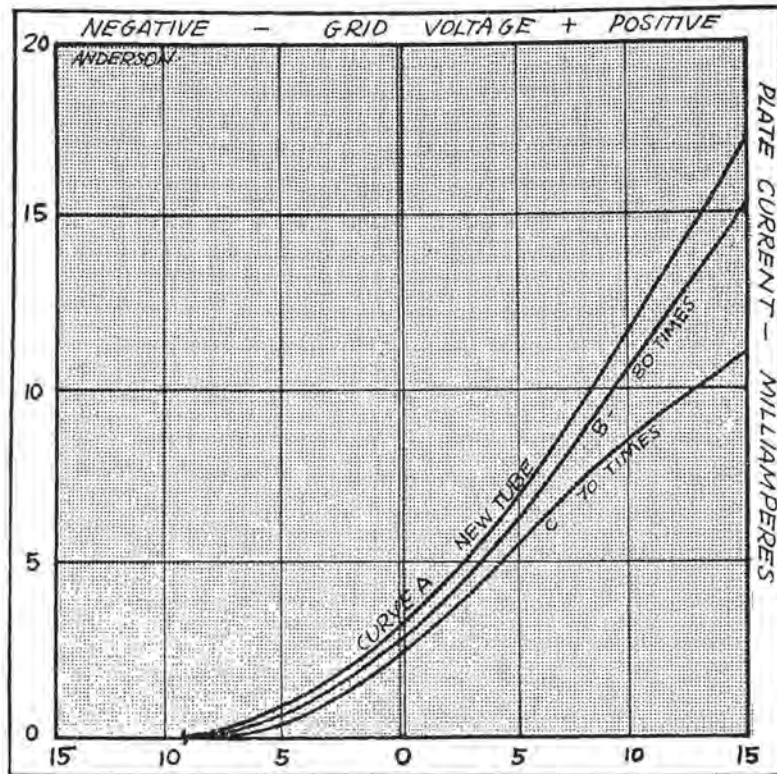

Figure 3. The above curves of a standard vacuum tube, which had been rejuvenated 70 times, serves to indicate that exceptionally long operating life is attainable when the tube is renewed at regular intervals.

third Curve C, which shows the tube 84% efficient after being renewed seventy times—you can well guess that the time elapsed between the 70 renewals must have been considerable.

"Dud" Tubes Cause Troubles

AFTER a set of radio tubes have been giving service all winter, they are in no position to properly detect and amplify the weaker signals of summertime. Rejuvenation of such tubes will tend to greatly improve summer radio reception and make it possible for everyone to enjoy the splendid summer programs.

Multi-tube sets, notably superheterodynes, radio frequency receivers and neutrodynes are so largely dependent upon maintenance of tube characteristics for satisfactory reception that periodic renewal is an imperative necessity. Neglect of this will mean that the set will gradually become lower in efficiency, presenting new and baffling ailments.

One weak tube in a circuit, that uses several tubes on a universal rheostat control, will keep the entire set of tubes from functioning properly—because of the excessive potentials applied to the normal tubes in an effort to get the best out of the weaker one. The tube manu-

facturers explicitly specify that greatest results are obtained only when the values of current specified by them are maintained.

Policing the Ether

BROADCAST listeners, prone to criticize the amateurs, even though they may be actually operating within their rights, should be pleased to know that the Department of Commerce radio officials actually try to police the air and have offenders who interfere with broadcast reception punished.

The actual punishment, however, really lies with the courts of justice, which prosecute cases properly presented by the radio supervisors. In a recent case, an unlicensed amateur named Roger M. Daugherty, of Dayton, Ohio, who operated a set illegally with a false call, interfering with radio service, and of course broadcast reception, by broadcasting phonograph records on wave lengths 340 and 400 meters, was sent to court and fined \$25.00 by Judge Hough. Furthermore, he was sentenced to remain in jail until he paid his fine; which he did quite promptly.

Could Have Obtained License

This amateur might have secured a proper license to operate on specified wave lengths below the broadcast band and enjoyed his radio experiments by communicating with other amateurs, but he ignored the Federal Laws, broadcasting when and as he pleased. The result was that he caused hundreds of complaints to be filed with the Government inspectors by indignant broadcast listeners from miles around. His broadcasts even interfered with reception of stations outside Ohio, thus becoming an interstate offense. As far as can be determined, he has been on the air about two years, during which time Supervisor Edwards of the Eighth District and his inspectors have been trying to locate his transmitter and catch him operating it. Eventually, however, they did so. Although it was a nominal fine, the Supervisor believes that the lesson and the example will be as beneficial to the radio service, as if he had been given the full penalty of \$500.00 and had his apparatus confiscated.

Warned Frequently

The worst thing about this case was the fact that Mr. Daugherty was warned several times and advised that he was breaking the radio laws. However, he ignored the warnings and persisted in operating his station under the false call letters 8COF. Inspections of his home failed to reveal the transmitter until recently, as it was concealed.

RADIO THEORY SIMPLIFIED

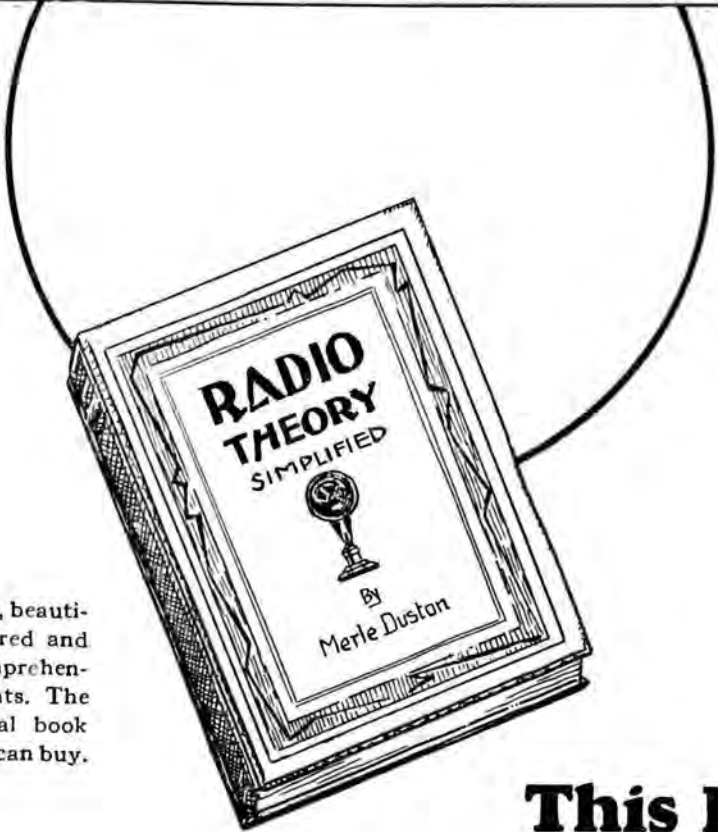

Handy in size, beautiful in black, red and gold, and comprehensive in contents. The most practical book on radio you can buy.

184

CLOTH BOUND

Pages that will help you to understand your set

This Book shows you how to get MORE out of radio

YOU can't expect to get the most out of radio unless you know something about its theory. You can't run a car efficiently unless you know something about 'what makes the wheels go round.'

RADIO Theory is a beginner's book written by Merle Duston, who knows how to explain the mysteries of radio. Its text is simplified by graphic illustrations that leave nothing to puzzle. This book acquaints you with the basic electrical laws governing radio, in a pleasant understandable manner and devotes its final pages to clear explanations of involved and intricate circuits that are readily comprehended.

 ON THE AIR,
 Kimball Hall, Chicago, Ill.

Enclosed find \$1.50 (cash, money order or check) for which you may send me ON THE AIR for one year, beginning with the current issue, and Radio Theory, FREE!

Name.....

Address.....

Whether you already are a radio fan or intend to be, you should have a copy of Radio Theory in your library. To keep posted on developments and new findings in radio, you need the monthly issues of ON THE AIR.

The two are invaluable aids to a better understanding of radio; the lucid easy explanation of RADIO THEORY is but a stepping stone to complete enjoyment of the up to the minute discussions of radio developments in ON THE AIR. Radio Theory is the basic rules of radio as you should know them; the monthly issues of ON THE AIR are the practical applications of the theories set forth.

Fill in the blank today, Affix your name and address to the coupon, mail it with your remittance, and we will forward you a copy of Radio Theory and in addition put your name on our subscription list for one year.

Do It Now!

ON THE AIR
 Suite 1322 Kimball Hall
 Chicago, Ill.

(Continued from page 40)

6:30-7:30. These stations are all constant repeaters, have had them all many times. The set I use is a Freed-Eiseman Model No. 5.

Yours for success,
Jack Koontz.

Box 14,
Waupaca, Wis.

P. S. I hope this gets published for the sake of the "Neut." By the way—to date I have received 158 stations not including amateurs.

LONG DISTANCE!

Here lie the remains of a
radio fan
Who insisted on smoking
a pipe,
He wandered into a
gasolin plant,
And was
Picked up
By twenty-one
Stations
That night!

W. L. Reed of 614 Lafayette Street, Jamestown, N. Y., writes in and tells us, "I am a subscriber to your dandy magazine and more power to you. There are few radio magazines that I miss—but I guess I'm partial to ON THE AIR. The only trouble is that when I receive my copy I read it from cover to cover about four times and then it's a long wait till next month!"

Thanks (blush) Mr. Reed.

Leo J. Smith of Fort Plain, N. Y. sends in a list—such a list—a mile long. He's got a set that he can hear a fly crawl on the wall down at Havana, Cuba, and gets everything from Alps to measles with it. Wants to know if we ever sleep here in Chicago. To that we'll answer "once in a while." Just enough to keep us from having to prop our eyes open with match sticks.

H. W. Hudelson of Vandalia, Mo., crammed his list of stations into an envelope and when we opened the letter we thought we were getting the latest broadcast list from our Washington news correspondent. He says: "On the night of November 20th I brought in 57 stations 5 of which are on the Pacific coast, 1 in Mexico and the rest from all over the U. S. A. His record is of January 14th, 1925 when he tuned in 72 stations before 1 o'clock at night. This fellow sure lives up to his name. He Hudelson (say it fast) close to his radio set and coaxes the signals down the grid wire.

TELEGRAM. COLLECT CHECK 24 CHICAGO, ILL. 2/26 WH REES 3145 BURY MT NYC STOP HOPE YOU GOT EUROPE FOR THE WIFE IN TRANS-ATLANTIC TEST STOP TELL HER NOT TO SWEAR WHEN YOU CANT TUNE IN KFI REGARDS.

ON THE AIR



THE WORLD'S SMALLEST BROADCASTER

Compare this tiny 5 watt transmitter with that of WJZ's on page 40. This is the oscillator of station WDBX of New York City. The photo shows Miss Florence Bauer at work making adjustments before the station goes on the air.

Were you one of the many subscribers that were worried about your subscription when we came out late? We're sorry if we caused you anxiety and inconvenience, but the things in our subscription department have been one—well have been one terrible mess. All fixed now though and you should get your magazine regularly even though we are a little late. We're trying to make ON THE AIR better and better each month and sometimes it takes just a few days longer to get some good feature into print. Here's how one of the fellows felt about it:

ON THE AIR,
Chicago, Illinois.
Gentlemen:

Received my first copy of ON THE AIR today and am tickled pink with it. I was thinking for a while I had been stung in forking over for a year's subscription and wrote earlier this week asking you about it. Now I have come to the conclusion that I have been blessed instead of "rooked" and I want you to know that I intend keeping up my



W. W. Martin is a regular DX hound. He is one of the many Feedback fans of ON THE AIR and is always busy at trying out new hookups. The photo shows him testing out a new receiver with which he has heard 6LV London. It uses a special tuned loop and an outside antenna.

subscription so long as I can earn, beg, borrow or steal the price.

Good Wishes

Thos. Brearey
27 1-2 Hickory St.,
Rochester, N. Y.

P. E. Miller of 1252 N. Campbell Ave., Chicago, Ill. writes us and says he likes ON THE AIR, and regrets that he did not come across it sooner. Best of all though he likes the Feedback pages (AHM!) and hopes that more of the fellows will avail themselves of the opportunity to compare "fan" circuits.

It's up to you as readers—send in your "pet" hookups and we'll print just as many as we can find room for. We select them at random from the files and show no partiality because we don't accept responsibility for what you say. You're all part of the big family, and if you snub your relations it's not our fault.

If you have corns on your ears from tuning in on the European Trans-Atlantic tests try Bunko Corn Cure on sale at all radio stores (Advertisement).

Which reminds us we've got to telegraph 2LO London and have them sing the latest song "Of All My Wife's Relations, I Love Myself The Best."

Mr. E. P. Peck of the Utica Gas and Electric Corporation, 222 Genesee Street, Utica, N. Y. an officer of the Utica Radio Association sends in a report on interference created by man made machines. It is an interesting paper and fans who are having trouble with "artificial" interference should write for a copy of this paper.

We are also in receipt of a letter from Charles Ruge of the Kellogg Switchboard and Supply Company of 1066 W. Adams Street, Chicago, Illinois telling us that his company has developed equipment for interference from telephone bell-ringing systems. Readers who are having telephone ringer QRM should get in touch with Mr. Ruge direct mentioning ON THE AIR as the source of their information.

Homer Elam of Florress, Kentucky, writes us telling about the unusual luck he has had with his 2 tuber. He has a list of 56 stations in one night which is remarkable. Of the stations he lists, four are California stations. His total list is 195 stations. And he's going to write us telling if he got Europe—so he promises.

Here's a little parlor stunt that we'll close with. It can be worked out nicely and will give lots of pleasure.

By placing your loud-speaker in one
(Turn to page 64)

The Freedom of the Air is Questioned

(Continued from page 8)

division of time in the interests of the public and the broadcasters is obtained, Zenith will consider its efforts well worth the sacrifice, even though it might itself be unsuccessful in obtaining a reasonable share of the time for its own use.

Our action has been referred to in the press as "Piracy of wave band not in use by any broadcasting station in the United States." With reference to this I am reminded of the statement by one of the most eminent leaders in England's politics, when in discussing the land laws of his country said, "What finger wrote the law that made us trespassers in the land of our birth?" With apologies to the Honorable Lloyd George I say, "what finger wrote the law that makes us pirates in the free air of America?"

At the time we go to press, the Zenith Station WJAZ is continuing what the daily press terms "Pirate Broadcasting." The local radio inspector Mr. E. A. Beane has wired Washington for further instructions in the matter, as he is powerless to act, not knowing just how much power he has. The officials at Washington and the Secretary of Commerce are in turn busily engaged in finding just how and why the Zenith station has violated the law, and what legal action can be taken against them.

All we can hope for is that radio gets a decent break, and that the matter will offer a solution to the present problem that is progressive to the interest of future broadcasting.

This is but one of many equally interesting events which Commander McDonald was able to establish as a precedent in the more serious side of radio transmission and reception and it has removed all scepticism with regard to the stability of radio and any question as to whether radio is an integral part of civilization from which it can never be divorced.

Radio Conquers the Arctic

(Continued from page 16)

the call out over the air.

In a few moments came the answer.—"W N P standing by."

The operator at Arlington Heights then informed the treasurer that he had the S. S. Peary and the messages was given him and transmitted to chief operator McGee on board the S. S. Peary. McGee replied that McDonald was away from the ship but that he would send out a call for him and in a few moments McDonald was located and reported back to his ship, read the message and dictated the reply to McGee.

As McGee clicked the key, the operator at Arlington Heights repeated each word to the treasurer at the Zenith offices and in less than twenty minutes, McDonald had been acquainted with the question on hand, had gotten his reply back to the committee and then resumed his research work in the Arctic as the meeting was concluded in Chicago and the committee was, in a position to act intelligently.

THORDARSON

Super
TRANSFORMERS
Standard on majority of quality sets

In sets priced
as high as
\$2000
you'll find
Thordarsons!



 S your radio set lacking in clearness and volume? To give it a tone quality comparable with that of the finest receiving instruments, replace the present audio frequency transformers with Thordarsons. Your dealer carries Thordarsons, identical with those used by nearly fifty leading manufacturers whose sets are priced as high as two thousand dollars each. Follow the lead of the leaders—amplify with Thordarsons. Write for interesting literature.



Types and Prices

Thordarson Super Audio Frequency Transformers, sub-panel or top mounting type: 2-1, \$5; 3½-1, \$4; 6-1, \$4.50. Thordarson Power Amplifying Transformers, \$13 pair. Thordarson Interstage Power Amplifying Transformers, \$8 each. Thordarson Auto-formers, \$5 each. All Thordarsons are unconditionally guaranteed. If dealer cannot supply, order from us.

THORDARSON ELECTRIC MANUFACTURING CO.
Transformer specialists since 1895
WORLD'S OLDEST AND LARGEST EXCLUSIVE TRANSFORMER MAKERS
Chicago, U.S.A.

ZENITH
KENNEDY
WV
Radiodyne
Planstiehl
Howard
Thermodyne
OZARKA
Deresnadyne
ADLER-ROYAL
MURDOCK
MU-RAD
Valleytone
LEICH
Silver-Marshall
GLOBE
Inter-circuit
Newport
BUCKINGHAM
NUNN-LONDON
KUSTOMBILT and
many others
use Thordarsons

Also choice
of the
MacMillan
Arctic
Expedition

Stop Tuning by Guess

Use RADEX and get stations
you never got before

RADEX shows—

your dial positions for more than 600 stations
the name of the station received without
announcement.
the wave length to which your set is tuned at
any time.

25c at most good radio stores
postpaid, coin or stamps

THE RADEX PRESS
Box 143D Cleveland, Ohio

VICTOREEN

SUPER-HETERODYNE

Coast to coast on loudspeaker with
inside loop aerial. The set you
will eventually build.

We have Complete kits for the construction of the phenomenal Victoreen Super-heterodyne the wiring diagrams of which appear in this issue of ON THE AIR. Everything from transformers, cabinets to binding posts. Write for blue-prints and prices. All equipment as specified. Dealers wanted.

NELSON ELECTRIC CO.

508 Dearborn St.

Chicago, Ill.

On the Air Research



Radio Laboratories

With the general improvement of radio apparatus in mind and with the object of presenting the arguments of the manufacturer to the reader in a way that places responsibility with this magazine, we are maintaining the On The Air Research Laboratories as a part of this organization.

Manufacturers disposed to do so may send apparatus to this department for test and approval. If the apparatus does not pass the requirements, it will be returned to the sender with suggestions for improvement. Each approved device is awarded a certificate, with permission to use the seal of approval of the laboratory shown above.

VICTOREEN MANGANIN RHEOSTAT

Test No. 170. The rheostat submitted by the George W. Walker Company of 6544 Carnegie Ave., Cleveland, Ohio, is unusual in several ways. It is wound with genuine manganin wire, affording double the number of turns of wire usually encountered in rheostats. Tests show it has a zero temperature co-efficient and that the resistance remains uniformly the same regardless of temperature. It has three terminals instead of the customary two for the purpose of making either right or left hand connections. The laboratory had the pleasure of testing the four sizes, 6, 10, 20 and 30 ohms and reports that they have been

AWARDED ON THE AIR RESEARCH LABORATORY CERTIFICATE OF MERIT AND APPROVAL NUMBER 270.



KARAS SLF CONDENSER

Test No. 171. Before assembling the Karas SLF condensers used in our 1926 RF receiver into the working circuit of the set, we turned the stock samples over to our laboratory engineers to test for losses and field as well as straight-line characteristics. We find that they are highly efficient, admirable pieces of radio workmanship and that the straightline curve is one of the truest we have yet charted. The .00035 Mfd. sizes submitted were sent us by the Karas Electric Company of 4040 N. Rockwell St., Chicago, Illinois.

AWARDED ON THE AIR RESEARCH LABORATORY CERTIFICATE OF APPROVAL AND MERIT NUMBER 271.



MUSSELMAN TUBES

Test No. 172. We have had the pleasure of testing the standard series of Musselmann tubes and our previous report shows them to be one of the finest tubes on the market. We are heartily in accord of their sales policy which requires an individual curve of each tube packed in the box. Their latest contribution to the market of radio tubes is the new Musselman 5 Power Mogul. A checkup on the characteristic of this tube shows it ideally suited for the last stage of audio amplification. The samples tested proved to be exceptionally uniform. Made by the Van Horne Company and distributed by A. J. Musselman of 655 Machinery Hall, Chicago, Illinois.

AWARDED ON THE AIR RESEARCH LABORATORY CERTIFICATE OF MERIT AND APPROVAL NUMBER 272.



CENTRALAB MODULATOR CENTRALAB RESISTANCE.

Test No. 173. The Centralab Modulator, manufactured by the Central Radio Laboratories of 16 Keefe Avenue, Milwaukee, Wis., illustrated above was laboratory tested before assembled in our 1926 RF receiver and was found to be a smooth efficient control of the power of the last audio stage. A checkup on the resistance value of the non-inductive segment shows it to be close to the rated value. The 200 M resistance used in the 1926 RF receiver was also tested and found to be equally as efficient as the modulator.

AWARDED ON THE AIR RESEARCH LABORATORY CERTIFICATE OF MERIT AND APPROVAL NUMBER 273.



PROUDFOOT COILS

Test No. 174. The Proudfoot coil manufactured by the Cruver Manufacturing Company of 2456 West Jackson Blvd., Chicago, Ill., was rigidly tested for amplification characteristics with the Musselman tubes during the process of experimentation with the 1926 model RF receiver. Its design embodies several unusual features, including low losses and sharpness of resonance. Our laboratory finds it to be one of the outstanding developments of radio design that has appeared this season, due to the fact that it comes closest to the coils of the Bureau of Standards that as yet have been manufactured.

AWARDED ON THE AIR RESEARCH LABORATORY CERTIFICATE OF MERIT AND APPROVAL NUMBER 274.



STERLING TUBE TESTERS

Test No. 175. In compliance with our policy of testing out the products of advertisers in ON THE AIR our laboratory was instructed to secure one of the Sterling Tube testers manufactured by the Sterling Manufacturing Company of Cleveland, Ohio and test it. They selected the R401 type, the one commonly used by the radio fans for home use and made several checks with it on various tubes. The meter was carefully checked and the operating characteristics of the tester were noted in an effort to determine whether or not it is a worthy piece of apparatus to recommend to the radio fan. We take pleasure in announcing that it has been AWARDED ON THE AIR RESEARCH LABORATORY CERTIFICATE OF APPROVAL AND MERIT NUMBER 275.



DONGAN TRANSFORMERS DONGAN CHOKES

Test No. 176. The Dongan Electric Manufacturing Company, 2987 Franklin St., Detroit Mich., submitted samples of their transformers and chokes used in the Raytheon Tube B Unit. After careful test of their voltage limits and maximum power limits, we are ready to award them a laboratory certificate. These units are neatly designed efficient power supply accessories for fans looking for B eliminator equipment. AWARDED ON THE AIR RESEARCH LABORATORY CERTIFICATE OF MERIT AND APPROVAL NUMBER 276.



WALBERT UNIVERNIER DIALS

Test No. 177. Dial illustrated above was submitted Walbert Manufacturing Company, 925 Wrightwood Ave., Chicago, Ill., represents several unusual ideas in vernier design. It is of the gear reduction type, having a twelve to one ratio of action. It is designed to use a separate erasable logging slip, which is fastened directly under the main dial, which is in turn calibrated in degrees. We take pleasure in awarding this dial ON THE AIR RESEARCH LABORATORY CERTIFICATE OF MERIT AND APPROVAL NUMBER 277.



CROSLEY RECEIVER 429

Test No. 178. We have had the pleasure of testing the new Crosley 429 receiver manufactured by the Crosley Radio Corporation of Cincinnati, O. It is a four tube receiver with a circuit of new design incorporating one stage of non-oscillating radio frequency amplification, and regenerative detector controlled by what is termed Crescendon knob. After complete operating test on the receiver, we are glad to AWARD ON THE AIR RESEARCH LABORATORY CERTIFICATE OF MERIT AND APPROVAL NUMBER 278.



PONTIAC RECEIVERS

Test No. 179. The radio frequency receiver manufactured by the Pontiac Radio Co., 25 E Jackson Blvd., Chicago, Ill. This was referred to our testing laboratory for inspection and operating test, and a careful check was made on its operating performance. It is a five tube tuned radio frequency set of the latest design, giving satisfactory results, when placed in the hands of the average broadcast listener. AWARDED ON THE AIR RESEARCH LABORATORY CERTIFICATE OF MERIT AND APPROVAL NUMBER 279.

BURNS LOUD SPEAKER

Test No. 180. The Burns Loud Speaker manufactured by the American Electric Co., 6400 So. State St., Chicago, Ill., satisfactorily passes the requirements for loud speakers of On The Air Research Laboratory. We find it reproduces with excellent quality with maximum efficiency at one thousand cycles. This speaker will give excellent results when used with the average radio set availing plenty of volume without blasting. **AWARDED ON THE AIR RESEARCH LABORATORY CERTIFICATE OF MERIT AND APPROVAL NUMBER 280.**



THOROLA LOW LOSS DOUGHNUT COILS

Test No. 181. We have made several tests on doughnut coils in our research laboratory and find that one of the outstanding types in the tests is that of the Reichmann Company of 1725 W. 74th St., Chicago, Illinois. The coil illustrated above has a special winding which reduces the distributed capacity to a minimum extent and has few losses due to dielectric absorption. This is the standard coil used in their Isodyne receiver which is popular among broadcast listeners.

AWARDED ON THE AIR RESEARCH LABORATORY CERTIFICATE OF APPROVAL AND MERIT NUMBER 281.



PETITE CRYSTAPHONE

Test No. 182. The combined headset and radio receiver of the Petite Radio Corporation of 459 Little Building, Boston, Mass. as illustrated above is an unusual piece of radio apparatus. It is distinctly a novelty but is in no way a toy since it is an efficient crystal set capable of excellent local reception with an appropriate antenna. We do not advise using this combination headset and receiver in congested districts as the selectivity is not especially great.

AWARDED ON THE AIR RESEARCH LABORATORY CERTIFICATE OF MERIT AND APPROVAL NUMBER 282.



BENJAMIN TUBE SOCKET

Test No. 183. Our engineering staff acknowledges with pleasure the receipt and test of the Benjamin tube socket. It is a decidedly better socket than the average since it incorporates a very effective anti-microphonic spring suspension that eliminates noises. The contacts are positive and firm, and the socket is so designed that it will accommodate all of the present day tubes, including the UX and UV types. It is manufactured by the Benjamin Electric Company of 120 S. Sangamon Street, Chicago, Illinois.

AWARDED ON THE AIR RESEARCH LABORATORY CERTIFICATE OF APPROVAL AND MERIT NUMBER 283.



WORKRITE NEUTRODYNE RECEIVER

Test Nos. 184, 185. In accordance with our policy of testing out manufactured equipment advertised in pages of ON THE AIR we loaned one of the popular Workrite Neutrodyne models from a local dealer and conducted several tests on the receiver. We find that the set passes our requirements as to selectivity, range, volume and quality of tone, and are happy to award it one of our certificates. Manufactured and sold by the Workrite Manufacturing Company of 1816 E. 30th St., Cleveland, Ohio.

AWARDED ON THE AIR RESEARCH LABORATORY CERTIFICATE OF APPROVAL AND MERIT NUMBER 284.

**ON THE AIR
Radio Research Laboratory
Certificates**

are awarded to manufacturers of apparatus who submit samples of the devices they manufacture. To acquire a certificate for a product the following requirements should be observed:

1. A sample for test should be carefully selected and forwarded to ON THE AIR Radio Research Laboratories, Room 1322 Kimball Hall Building, 306 S. Wabash Ave., Chicago, Illinois.
2. A letter stating that the device is submitted for approval and test should accompany the package.
3. This service is maintained for non-advertisers as well as space users of ON THE AIR magazine. Any manufacturer is free to submit apparatus for a certificate.
4. Apparatus passing the laboratory requirements will be returned whenever possible. At times tests require the dissection of the sample submitted. In such cases, we will notify the manufacturer.
5. Apparatus not passing tests will be returned whenever possible to the sender with suggestions for improvement.
6. Advertising writeups for these pages will not be accepted. Only actual tests will appear in the columns of ON THE AIR Radio Research Laboratory department.
7. Upon completion of tests, a certificate is furnished regarding the tests signed by our technical editor.

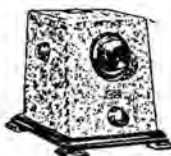

WALBERT PENETROLA

Test No. 186. Our technical staff, being very much interested in the performance of a new RF booster unit that has made its appearance on the market, secured one of the Walbert Penetrola attachments illustrated above and went to work to check up on the claims made for it. The circuit arrangement is especially interesting we find, and we are glad to say that we have found an effective RF booster that we can recommend without mental reservations. Made by the Walbert Manufacturing Co. of 922 Wrightwood Ave., Chicago, Illinois and **AWARDED ON THE AIR RESEARCH LABORATORY CERTIFICATE OF MERIT AND APPROVAL NUMBER 285.**



KODEL MICROPHONE LOUDSPEAKER

Test No. 187. This loudspeaker sensation that has taken a great number of radio fans by storm was tested in our laboratory for percentage of volume, faithfulness of reproduction and quality of tone over the musical scale of from 100 to 4000 cycles, and we are pleased to report that it is deserving of our certificate. It is manufactured by the Kodel Radio Corporation of 505 E. Pearl Street, Cincinnati, Ohio, and has been **AWARDED ON THE AIR RESEARCH LABORATORY CERTIFICATE OF MERIT AND APPROVAL NUMBER 286.**



FROST UNIVERSAL SOCKET

Test No. 188. The Frost Socket illustrated above is designed to take all tubes with the new type bases. Has perfect spring construction which grips each tube prong full length with self cleaning sliding contact. The terminals are plainly marked, and the socket comes complete with soldering lugs. It is a high quality socket at a low price. Made by Herbert H. Frost, Inc., 314 West Superior St., Chicago, Ill.

AWARDED ON THE AIR RESEARCH LABORATORY CERTIFICATE OF APPROVAL AND MERIT NUMBER 287.



**CARTER RHEOSTATS
CARTER JACKS**

Test No. 189. Our readers are quite familiar with the excellence of the Carter line of "Imp" accessories, jacks, filament switches, etc., as invariably they are specified somewhere in every requisition of materials for receivers. We made a checkup on the resistance values of the rheostats and found them to be as rated. The jacks are excellent pieces of mechanical workmanship, which in turn assure efficient electrical performance. Manufactured by the Carter Radio Co., 300 S. Racine Ave., Chicago, Illinois.

AWARDED ON THE AIR RESEARCH LABORATORY CERTIFICATE OF APPROVAL AND MERIT NUMBER 288.



**SCOTT WORLD'S RECORD
SUPERHETERODYNE**

Test No. 190. Inasmuch as the Scott Radio Laboratories of 33 S. Dearborn Street, Chicago, Illinois, has wisely ordered advertising space with us, and due to the fact that one of the members of our staff has been indulging in experiments with their super-heterodyne we are able to give a very gratifying report on the Scott Superheterodyne as assembled from the kit of parts manufactured by them. About the highest compliment we can pay them is that the Scott system does what is claimed for it—all its advertised feats are substantiated by actual accomplishment.

AWARDED ON THE AIR RESEARCH LABORATORY CERTIFICATE OF APPROVAL AND MERIT NUMBER 289.



FANSTEEL B ELIMINATOR

Test No. 191. The B eliminator illustrated above was tested in accordance with our advertising test policy, the unit in question having been furnished by the Ekko Company, Chicago, distributors for the Fansteel Products Company of Highland Park, Illinois. Two models were tested, the large and small types, and both units were found to be highly efficient and noiseless. The units are advertised in this issue of ON THE AIR by the Strauss and Schramm organization of Chicago, Ill.

AWARDED ON THE AIR RESEARCH LABORATORY CERTIFICATE OF APPROVAL AND MERIT NUMBER 290.

BUY
equipment that has the
approval of ON THE AIR

It is your assurance that
the equipment is worthy
and efficient

A Reference Library on Radio

The Past Issues of ON THE AIR

READERS who are buying the "Magazine of Radio" for the first time may be interested in knowing how they can increase their fund of radio knowledge by reading some of the enlightening articles published in past issues of "On the Air."

ESPECIALLY are these numbers valuable to the fan interested in the technical side of radio. Back numbers of "On the Air" were noted for their up-to-date articles on taking care of your radio receiver, and improving its performance.

ALIMITED number of copies of the September, October and November issues of "On the Air" have been laid aside for readers interested in "On the Air's" laboratory developments. They may be had for the price of 20c each, postage prepaid. Following is a summary of the features in these issues:

SEPTEMBER, 1925

- Short Wave Broadcasting
- The Technical Editor's Set, Incorporating some unusual features of design
- The Browning Drake Receiver
- The Super-autodyne
- Operating the Famous Deresnadyne

NOVEMBER, 1925

- Rehousing Your Set for the Winter
- Remedies for Interference
- The Vacuum Tube Question
- Pepping Up Your Reinartz Set
- Revitalizing the Neutrodyne
- A 3-Stage Audio Amplifier

OCTOBER, 1925

- Causes of Fading
- How to Make a Wavemeter
- How to Handle Interference
- What Set Shall I Make?
- The Celeradyne Receiver
- The Story of the Ultradyne

DECEMBER, 1925

- How Loud Is Light?
- Low Loss, and What It Means
- Reviewing The Trend of Circuit Design
- The Toroid Coil
- The "Counterphase" Receiver

JANUARY, 1926

- Instruments for Radio Use
- Explaining the Vacuum Tube
- The Superfrequency Receiver
- Designing the Applause Card
- Solving Radio Problems

20c A Copy
ON THE AIR

1322 Kimball Bldg.

Chicago, Ill.

The World at Your Fingertips

(Continued from page 18)

transferred my "etheric meanderings" to daylight hours. You may be aware of the fact that the short wave band, which I was operating on, is like the broadcast wave band in that greater distances can be covered at night than in daylight.

In the day time it was not uncommon to "chew the sock" with stations as far west as Topeka, Kansas. As a result of these pleasant chats, I have gained many lasting friendships. So if for no other reason than this, I consider the time devoted to amateur radio very well spent. However, another thrill was in store for me.

Bronx Talks to California in Daytime

In the late afternoon of July 8th, while tuning my receiver, I was very much surprised to hear the extremely feeble and very sharp signals of 6CHS who was testing on about thirty-nine meters. The extraordinary tone of his signals and the unusual clarity of the air at that time, made the chances of working him favorable. It is considered quite a feat to hear such a far away station as 6CHS, as this station is located in Santa Ana, California. Nervously I waited (it seemed an age) until he at last stopped sending his test signal and "signed." In a split second, I was on the air calling him, at first fast and then very slowly, at the same time fervently hoping that he would hear and answer me. I now recall how dumbfounded I was on hearing his response to my lusty efforts. That certainly was a grand and glorious day for me for when in the course of the quarter of an hour talk with him, I nearly broke all the buttons off my vest because he remarked "Daylight work on forty meters—new record hi!" If I had all the power of WGY at my fingertips to play with, I could not have felt any prouder. A week later I was reassured that the feat was not done under freak conditions, for I was advised by other Pacific Coast amateurs that my signals were constantly being heard, with good audibility, by them during the daytime.

Talks to MacMillan Expedition

IHAD occasion to sit at the set a few days after working the coast. The time was seven o'clock in the morning and having a few minutes to spare before going to business, I sat down before my "trusty" receiver. The phones had hardly settled into their customary places on my head, when I heard WAP signing off. Anyone interested in radio should know who had that call assignment. If you do not recollect ever seeing it in print, I will tell you who had it. WAP was the call letters of the steamer "Peary" of the MacMillan North Pole Expedition. The "Peary" was outfitted with short wave apparatus to insure reliable radio communication with the outside world from the frozen wastes.

Well, I had just heard their "call of e wild" and I took a chance and called em. I knew from reading the daily

(Turn to page 55)

Paris on a Victoreen!

Verified Reception from
Paris by Cadiz, Ohio,
Radio Fan



*Coast to Coast on a Loop
is easy with a*

Victoreen Super Heterodyne Built with "Tuned" R. F. Transformers of Air Core Construction

Additional Parts Required to Build a Victoreen Super Heterodyne

- 2 .0005 Variable Condensers
- 8 Vacuum Tube Sockets
- 2 .00025 Grid Condensers with Mounting
- 2 2 MEG Grid Leaks
- 1 400 OHM Potentiometer
- 2 30 OHM Rheostats
- 2 6 OHM Rheostats
- 2 Double Circuit Jacks
- 1 Single Circuit Filament Jack
- 1 Filament Switch
- 2 Audio Transformers
- 1 1 MFD Bypass Condenser
- 1 4½ Volt "C" Battery
- 1 7x24 in. Panel

Base Board—8¾x23x¾
Binding Posts, Screws, Bus Bar
and Solder Lugs

*Any good dealer will have these
parts in stock*

Complete parts for this set can be purchased
of your dealer for \$50 to \$75, depending on
quality of parts desired.



*Victoreen No. 170 R. F. Transformer—
Neat and Compact—3" in
diameter, 1" thick*

The Heart of the Circuit

- 4 "Victoreen" No. 170 R. F. Transformers—\$7.00 each
- 1 Victoreen No. 150 Coupling Unit—\$5.50 each

Should use of Aerial be preferred to Loop, the "Victoreen" No. 160 Antenna Coupler is required, at \$3.50, extra.

EITHER

UV199 or 201A Type of Tubes may be used—a truly Victoreen Feature

"B" Battery consumption is remarkably low—8-10 Milliamps, with Potentiometer at negative side—less than some 3 tube sets.

No Oscillations, Howls or Squeals—No Matching of Tubes

Victoreen Air Core Transformers are not merely "matched," but are actually tuned to a guaranteed precision of 1/3 of 1%—another Victoreen Feature

Range—Clarity—Volume—Selectivity—Ease of Operation

Ask Your Dealer for a Free Folder and Hook-up of the Victoreen Set—or Write Directly to Us. Your Dealer Is Prepared to Furnish You with All Parts Necessary

THE GEORGE W. WALKER CO.

6507 CARNEGIE AVENUE

CLEVELAND, OHIO

Branch Sales Offices Are Located at

- 50 Church St. New York City
- 719 Raymond St. Philadelphia, Pa.
- 2006½ Commerce St. Dallas, Texas
- 910 Terminal Sales Bldg. Seattle, Wash.

- 202 Sugar Bldg. Denver, Colo.
- 383 Brannan St. San Francisco, Calif.
- 508 So. Dearborn St. Chicago, Ill.
- 308 E. 17th St. Kansas City, Mo.
- 5553 Vernon Ave. St. Louis, Mo.

- 45 Ruggery Bldg. Columbus, O.
- 443 So. San Pedro St. Los Angeles, Calif.
- Box 321 Boise, Idaho
- 332 St. Catherine St. W., Montreal, Que., Can.

News of the Radio World



Maurice B. Silverman has been singing quite often from station WBBM and says he likes it. In fact he gets a "kick" out of it to put it his own way.

THE pleasing voice of Maurice B. Silverman has become an established institution. His ability to adapt his song and style to fit the program is responsible in a great measure for the well deserved popularity he has attained.

Mr. Silverman selects his repertoire in accordance with the requests from his audience.

And so in response to the demands of a number of his admirers we present this opportunity of peering beyond the microphone into the life of the popular entertainer.

But let Mr. Silverman tell about it in his own way:

"Broadcasting gets into the system," he says. "I suppose a good and terse description of why I enjoy it is to say I get a great big kick out of it. I have been singing as far back as I can remember. In fact, when I was a youngster my ambition was to be an actor. I don't know why, because nobody ever accused me of having talent that the world would pay a price to see and hear. Anyway, I never did quite realize my ambition, except to take part in amateur theatricals—mostly singing parts. Now I'm an advertising man. Who knows—perhaps broadcasting and advertising to me were synonymous.

"It was just one of those little incidents that got me to be an air bug. I was tuning in long distance stations one evening and I got some strange sounds on new dial readings. I thought surely I had Honolulu—until the announcer brought me back close to home. In fact, it was so close that I could see the towers from my back porch. You guessed it. It was station WBBM. A day later I quite casually remarked to a friend who resides in the Broadmoor Hotel where the station

is located, I would like to sing over the air. In a few days I got a call to c'mon over. I went to the home of Mr. Atlass, owner of the station, stood before the mike, and—there you are.

Storad Has New Eliminator

Realizing that the public will be much more enthusiastic about radio when the problem of A and B circuit power has been solved in such a manner that all work and worry is eliminated, the manufacturers of batteries, radio equipment, battery eliminators, radio tubes, etc., have been making every effort to invent a power unit that will be automatic in action and furnish current that will give perfect radio reception.

The Storad Automatic Radio Power Supply is the newest and most complete power and control unit to be offered to the radio public. Storad engineers have introduced new principles in this unit which go a long way toward simplifying the radio power problem. The unit is entirely automatic in action. All the operator does is turn the switch on the set.

A short description of its action will make clear just how it operates.

The unit consists of an automatic storage A Battery charger and a complete and reliable B power supply. The manufacturer has designed a special storage A Battery for use with this Power Unit, or if desired, any ordinary storage A Battery can be used with satisfactory results. The unit is connected to the house lighting circuit with customary connections to the set. It may be placed near the set or in the cellar, garret or clothes press as desired, because this is the only power unit which does not contain a switch or control device to stop and start it. It is controlled entirely by the set switch.

When the set is in operation, current for the A circuit is drawn from the storage battery and for the B circuit from the B power supply which is part of the unit.

When the set is turned off, the charger immediately starts to recharge the storage A battery and brings it back to full capacity, when charging stops through the automatic control. Since the B circuit current is furnished by the power supply from the house lighting circuit, there is no further action in this part of the unit until the set is again put into operation.



The engineers of the Storad Manufacturing Company of Cleveland announce their intention of placing a new type A and B power supply unit on the market. Many fans will find this of interest.



Cleveland radio fans are well acquainted with the Workrite Melody Man shown hiding back of the 'mike' in the photo above. Guess who he is.

The unit is a big step ahead in radio and its general use will give added pleasure to an already most enjoyable and entertaining institution.

WorkRite Melody Man

Who is the man behind the microphone? He's the "WorkRite Melody Man," otherwise known as Joseph Ferte—Joe for short.

After singing with Ev. Jones and his gang at WTAM for about a year and a half, Joe has changed his allegiance and has signed up under the auspices of the WorkRite Manufacturing Co., Cleveland, Ohio.

The WorkRite hour at WEAR, Cleveland, is every Thursday evening at 8:30. In each appearance Joe will be assisted in a novelty program by other performers.

The "WorkRite Melody Man" and his assistants will shortly be heard from other stations, as an itinerary for a rather extended tour is being arranged at the present time.

Radio Audience 'Forgets Whiskers

Previous to their broadcasting "The Smith Brothers" of Poughkeepsie, N. Y., were best known and far-famed for their flowing whiskers, but since "Trade" and "Mark" have been heard by the listeners of WEAF they are pushing to the rear the prominence of whiskers in favor of their excellent rendition of old time songs.

"The Smith Brothers," two gifted singers, one being a tenor of beautiful full tone, and the other a baritone of vigor and power, are heard each week for one-half hour from WEAF, beginning at seven o'clock in a program of solos and duets, the majority of which are popular old time songs which they tastefully render.

The World at Your Fingertips

(Continued from page 52)

newspapers, that the ship was in the vicinity of Hopedale, Labrador. A minute or so later I had the unique experience of working him. The conversation was short-lived however when my good luck deserted me and I lost his already weak signals which were swallowed up in the terrific static which was prevalent at the time. I tried real hard to get in touch with him again that morning when I heard him calling "CQ" but no response was heard so I gave it up and went to work.

Next I had the novel experience of working a station on the other side of the globe—but it was no daylight working. You know as well as I that no matter what effect late hours and little sleep have on a radio fan, ham or broadcast listener, the itch for DX gets underneath one's skin and sooner or later it crops out in a form like this.

Build the Set That Holds 4 World's Records



The receiver that brought in stations 5,000 to 8,000 miles distant with loud speaker volume night after night. All records fully verified.

Holds World's Records For

- (1) Longest distance ever received on a loop aerial—8,375 miles.
- (2) Most constant reception of stations 6,000 to 8,000 miles distant—117 programs in three months.
- (3) Brought in 6 different stations in 2½ hours—all over 6,000 miles.

PRICE

Complete Set of Parts.....\$89.00 (Includes all parts necessary to make an exact duplicate of this wonderful receiver together with book of instructions and complete blue prints.)

Story of development and proofs of records sent on receipt of stamped and addressed envelope. Circular free upon request.

Scott Radio Laboratories
33 S. Dearborn St., Chicago

Dealers and Set Builders Write for Discounts

Three o'clock in the morning. All is still. Wait! All is not serene. A shuffling sound breaks the darkened atmosphere. Suddenly a light floods the room. It is not a burglar or "Raffles." It's any real DX hound.

Talking to Australia

I feel sure that you will agree for that is just the way I acted on the chilly morning of August 8th when I got up to "pound the brass." My precautions in not making any noise were well rewarded for I buckled down to real listening and about the first station I heard was very hard copying. After concentrating a while I succeeded in reading "CQ." Then I got accustomed to his swinging style of sending and I found out I was hearing A-2BC of Sydney, Australia. After the usual preliminaries, I worked him and as his signal strength increased tremendously no trouble was had in conversing with him. After nearly an hour of gabbing, we wished each other all kinds of luck and that brought my first Australian DX to a close. Some sensation that was to me. I did not try to sleep any more that morning for the thrill I got had enough kick to prevent me from even winking my eyes.

A few nights after I again "clicked" with WAP. Operator, P. J. McGee at the key told me he had no messages but gave me a position report of the "Peary." I learned that the steamer was at Etah, Greenland, and that it was the furthest away from home it ever would be on the exploration trip. Communication was not broken up this time by unfavorable conditions and I found great pleasure in the talk we went over. With a dah dit dah we finished.

In those few months I accumulated a vast amount of acknowledgment cards and letters which came from stations all over the globe. The cards of especial interest were placed around the map of the world, which is plainly seen in the station photograph. Twenty-five hundred other cards from stations in every state of the Union, the seven radio districts of Canada, Porto Rico, Hawaii, Panama, Cuba, Hayti, Mexico, Brazil, Argentina, Venezuela, Chile, the British Isles, France, Belgium, Germany, Switzerland, Italy, Poland, Finland, Denmark, the Netherlands, Morocco, South Africa, Samoa, New Zealand, Tasmania, Australia and ships in all oceans but the Antarctic are packed in a box in a remote corner of the station.

You have read the few experiences I have related and if you had the opportunity to read the cards I am sure that you would agree with me that amateur radio properly applied is one of the greatest diversions where thrills abound, research is made, friends are found and knowledge is gained.

RADIO THEORY

Will Help You to Understand Radio as You Should Know it. You Can Get a Copy FREE—

PAGE 47 TELLS YOU HOW



Inside of Almost Any Good Set—

If you'll lift up the cover of any good radio set and examine the controls closely, you are almost sure to find "Centralab" represented. And where you find Centralab controls, you have assurance of the best possible radio reception.

The Centralab Radiohm provides positive control of oscillation in radio frequency amplifiers when used in series with the plate or grid, or in shunt with the grid. Permits smooth, noiseless adjustment from approximately zero to the maximum of 2,000, 50,000, 100,000 or 200,000 ohms. Price \$2.00.

At your dealers—or mailed direct. Write for literature describing this and other Centralab Controls.

Central Radio Laboratories

15 Keefe Ave.,

Milwaukee, Wis.



APPLAUSE — The radio artist is doing all he can to make your evenings pleasant but it must be discouraging to do this without a little praise.

The old saying is give an artist a little applause and they will work their head off. The only way a radio artist can feel that his efforts are appreciated, is to send him an applause card. These you can have in a convenient form at \$1.35 per hundred with your name printed in a different color. Just fill out the coupon, don't send any money. Pay the postman on arrival plus a few cents postage.

B. A. BOWMAN, Bldg., Chicago, Ill.
You may send me 100 of your applause cards by mail. I will pay Postman \$1.35.
NAME _____ ADDRESS _____ CITY _____ STATE _____

AGENTS Big Money Quick!

COMBINATION KING RADIO WONDER
First combination tube and crystal set ever made. Turns a switch and either tube or crystal works as desired, or both together. 1000 Miles or more on headphones—loud speaker on locals. Two complete sets in one for only \$10.95 retail. Get my wonderful money making plan and special price to you.

Aerial Electric Co.
128-52 W. Kinzie St.
Chicago

You Want This Proposition—Write Today!

Detailed Diagrams for

By EARL CAMM

Staff Draughtsman

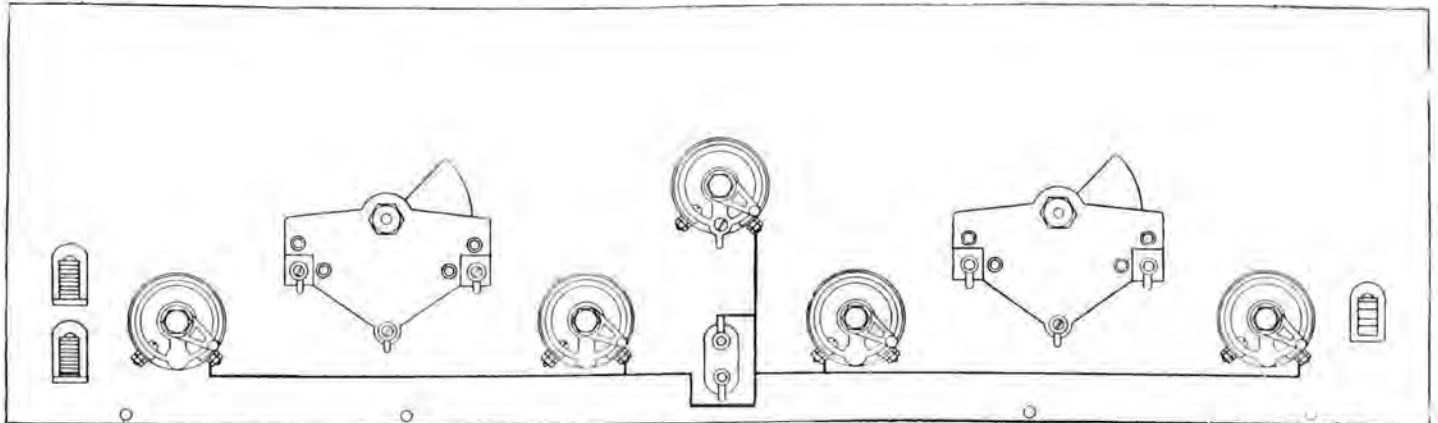
WIRING *the* MATCHED STAGE SUPER

1 After you have assembled the various parts on the panel and baseboard start your wiring with the negative filament circuit. Connect up the rheostats and filament switch

as shown using a hot soldering iron, and a good grade of solder. If you use soldering paste, apply it sparingly, and wipe off the joints you make with a rag saturated in alcohol

Use either copper bus bar wiring (tinned) or Belden Hookup wire for the connections. It is advisable to use soldering lugs carefully screwed down wherever possible.

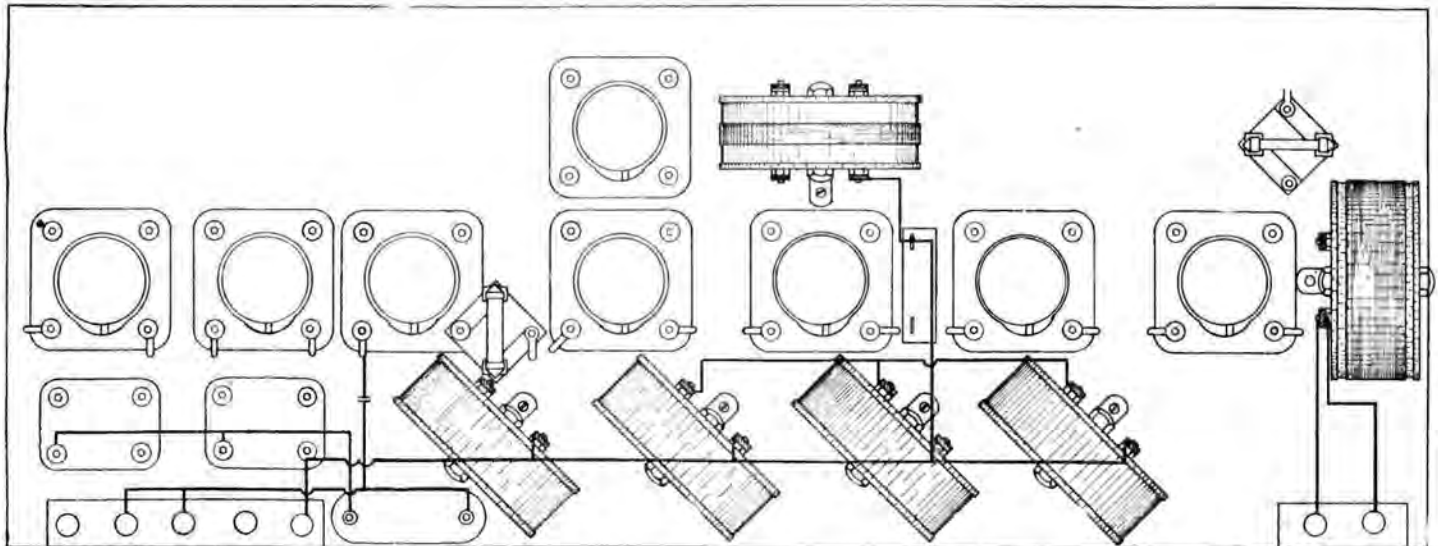

2 Proceed with the wiring of the connections shown above working on the baseboard with the panel unscrewed. This will simplify

connections greatly. This diagram shows the connections for the antenna and ground circuits, the intermediate frequency B power,

the oscillator B power, the grid return for the IF stages and the C battery circuit of the audio stages.

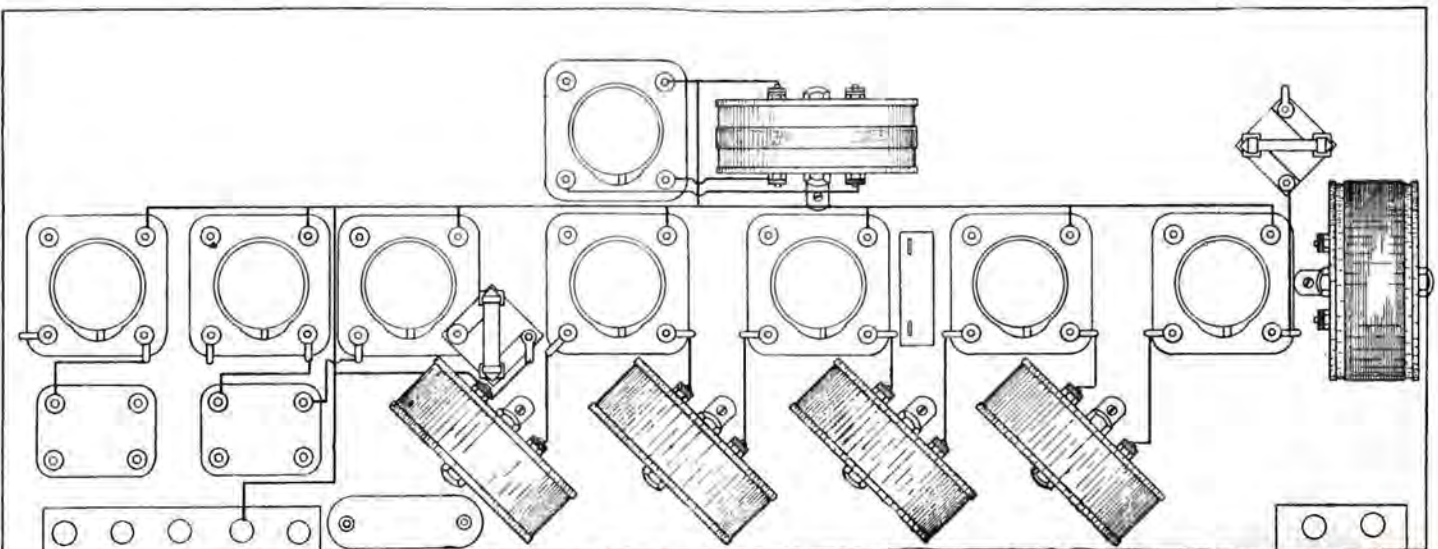

3 The wiring progresses as shown in the next diagram (above) and after you have made these connections, carefully check back over

the whole three circuits to make sure you have made no mistakes. Your next operation is to fasten the panel to baseboard and to com-

plete the wiring with the diagrams shown on page 58 of this issue, which show the wiring with the baseboard and the panel together.

No More "B" Batteries on Your Radio

At last, a practical reliable "B" battery eliminator for your radio. Does away with "B" batteries; no charging; no replacing. Always 100% efficiency in "B" current. The most revolutionary development in radio.

Genuine Fansteel
Balkite
"B"
Eliminator
Sent for Only

\$1.00
Down



U. S. PAT.
MAY 27, 1924

The Balkite "B" is connected to your radio just like "B" batteries and attached to an ordinary electric light socket. Replaces "B" batteries entirely and furnishes "B" current direct from regular house lighting current. Always gives current equal to four new and fresh 22½ Volt dry "B" batteries. For sets of five tubes or less. Simplifies radio receiving. More convenient, more economical and more efficient than dry or wet "B" batteries. Operates storage battery or dry cell tubes and gives tubes longer life. Entirely noiseless. Creates no disturbance in reception. Has no bulbs, nothing to break, wear out, replace or get out of order. Requires no change in your set, no extras to buy. Operates from 110-120 AC, 60 cycle current. Measures 8 3-16 inches by 8 inches by 3¼ inches. Current costs only 1-20 of a cent per hour.

\$5.00 a Month, if satisfied after trial

Only \$1.00 with the coupon below brings the Balkite "B" to your home on trial. Try it out thoroughly before you pay another penny. See how it improves reception. See how much more convenient than using batteries. Judge for yourself how it will save you money and make your radio set more enjoyable. Then, if not satisfied, send it back at our expense and we'll refund your \$1.00 plus all transportation charges. If you decide to keep the Balkite "B," start paying only \$5.00 a month until you have paid the total price of only \$35.00. That's the price others ask for spot cash. We give you the lowest cash price on easy monthly payments you will never feel.

Send Coupon

Don't miss this opportunity to get the genuine Balkite "B" at the rock-bottom cash price on easy monthly payments. Send coupon now while this offer lasts. Order by No. Y-8578A, \$1.00 with coupon; \$5.00 a month; total price \$35.00.

STRAUS & SCHRAM
Dept. R2212 Chicago, Ill.

STRAUS & SCHRAM, Dept. R2212 Chicago

Enclosed find \$1.00. Ship special advertised Balkite "B" Battery Eliminator. I am to have 30 days free trial. If I keep it, I will pay you \$5.00 monthly. If not satisfied, I am to return it within 30 days and you are to refund my money and any express charges I paid.

Balkite "B" Battery Eliminator, No. Y8578A, \$35.00

Name.....

St., R. F. D.
or Box No.....

Shipping
Point.....

Post Office..... State.....

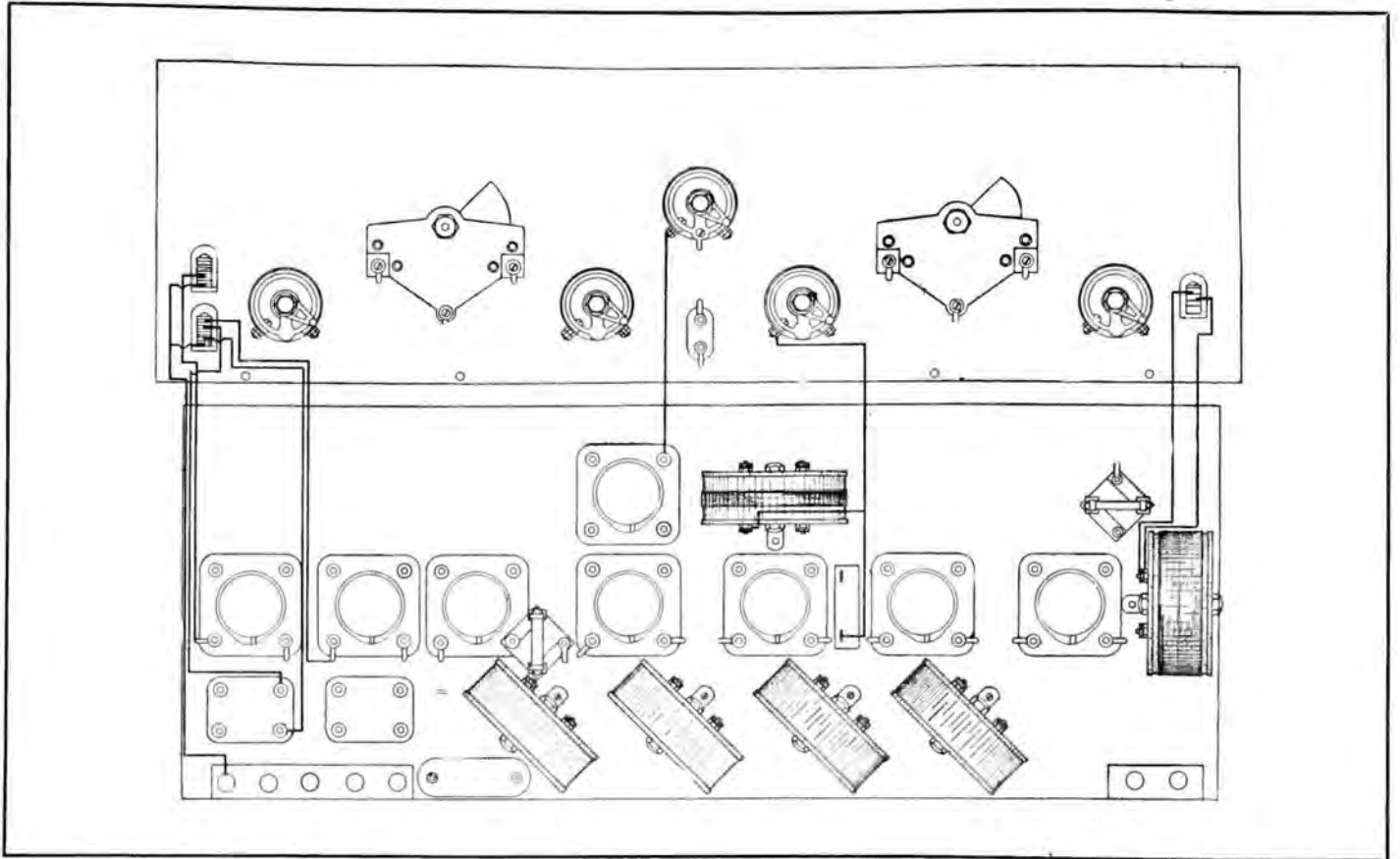

4 Great care should be exercised in keeping the wires from touching each other. The process of wiring grows more and more complicated as you continue but provided the diagrams are followed you should have little or no trouble.

If you are in doubt as to the polarity or connection markings on any of the units refer to your kit blueprint for information. The apparatus layout shown is the new arrangement devised by the designer of the set.

JUST AS WE PROMISED!

Complete diagrams showing the wiring of the Victoreen Superheterodyne as illustrated in our January number. We are making this special effort in response to the thousands of requests that come in asking for simplified detailed plans on wiring this unusual radio.

5 After you have finished the last wire of the print shown below you are ready to check over the entire system again. It is imperative that you do this if you want to make sure you are not going to blow eight tubes. One misconnection and the whole system is affected. Refer to the blueprint you receive when you purchase your kit for the legend of the parts and wiring. You can also use the blueprint as a checkback.

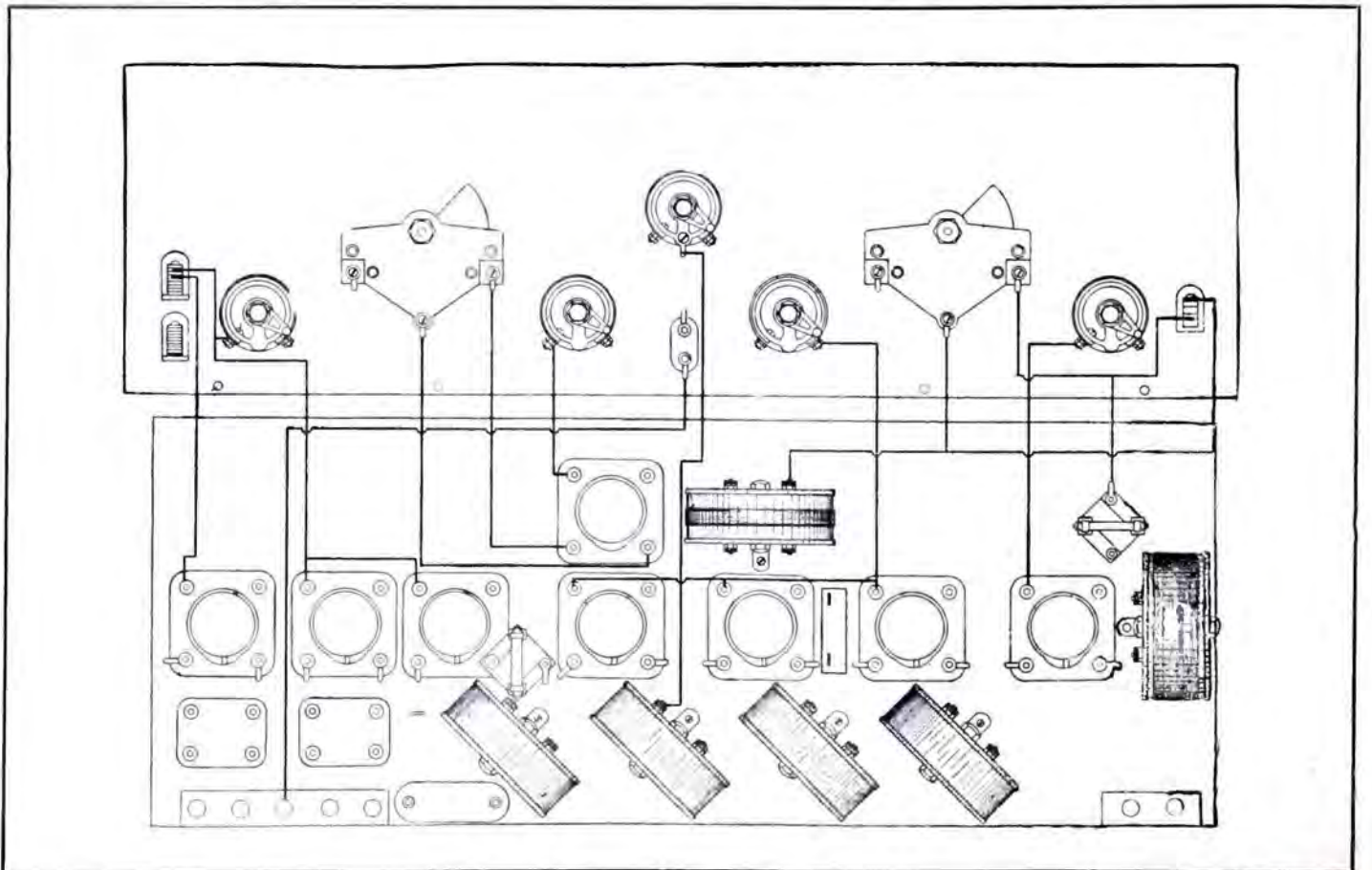

Congress Considers Radio Bills

(Continued from page 30)

necessary to transmit a message to an objective except in the case of distress signals.

Mr. Dill Says

Commenting on his measure Senator Dill said: "This bill gives the Secretary of Commerce complete and absolute power over the establishment of radio stations in the United States, but prohibits the right of censorship being exercised by him. It also prohibits rebroadcasting by one station of the programs of another station without the permission of the station. It provides for a Radio Commission of five members to which the Secretary of Commerce may refer questions and problems for report or for final action. If he refers the question for final action to the Radio Commission are subject to appeal to the courts within the District of Columbia or in the district in which the aggrieved party resides.

Mr. White Explains

CONGRESSMAN WHITE pointed out that his Radio Bill is in form and substance similar to the Bill introduced by him in the last Congress, although modified by incorporating provisions designed to make effective the recommendations adopted by the radio conference recently held in Washington.

The principal Radio Conference recommendations are in his Bill or power to carry them out will be found in the general authority conferred upon the Secretary. The Conference recommended that a licensee should have a property right in the call letters of his station, is not recognized in the Bill.

The provision for an Advisory Committee contained in the Bill of last year has been eliminated, and in its place there is a section creating a National Radio Commission to which the Secretary of Commerce may refer any matter over which he is given authority by the general terms of the bill.

It is recognized by all that the ether is over-crowded. Mr. White says those familiar with this means of communication appreciate that there are not sufficient wave lengths for all desiring so to do to engage in Radio transmission. The Bill is based on the theory that the right to use the air for radio transmission is not an absolute right, but that it is rather a *qualified or conditional right to be accorded to an applicant if public convenience, interest, or necessity will be served by the granting of the authority*; otherwise to be denied. A heavy responsibility is placed upon the Secretary of Commerce in the provisions of the Bill which requires him to pass upon applications for licenses, to allocate wave lengths, to divide time and to act in other respects.

The Radio industry is peculiar among all other lines of activity in the country in that it has recognized the necessity for and has sought legislation providing for its own regulation. The users of Radio have also manifested a belief in the need for some degree of control over the air.

The Function of the Coupler

(Continued from page 32)

Forced Oscillations

"This brings us to the question of what, in technical language would be expressed as forced oscillation, but in the picturesque jargon of the present day is termed 'slopping over'; in other words, that tendency of a near-by station to make itself heard over the entire dial. If by the process of reducing the coupling we can make a set more selective, why cannot such local stations be tuned out? It would seem to be merely a case of separating the coils further.

"And it is. All we need to do is to loosen the coupling, but we will find if we attempt to do this, that this degree of coupling is far too loose for the more distant stations. If all stations came in with the same intensity as the local station we are trying to sharpen, the coupling in our set would, of necessity, have to be extremely loose. But with many stations of low intensity and with one or two stations of high intensity, the coupling must be adjusted at an average value,—something not so loose as to eliminate the distant stations and yet, not so close as to make the local station heard over the entire dial.

"This action of the local station in occupying the greater portion of the dial readings is comparable to the case of the rigid pendulum swinging at some period other than that due to its length. As was pointed out earlier in this discussion, the pendulum may be forced to swing at a period other than that due to its length but it will require much more effort or energy than if it is made to swing at its natural frequency. In the same way, an electric circuit may be forced to carry an alternating current of a frequency other than the natural frequency of the circuit, but it requires considerable energy and in radio work it is only the high powered local station that can supply such energy.

"So the nearby high powered station will always remain something of a problem to the listener striving for long distance reception. However, by arranging a number of tuned circuits in series, such as is found in most of the two or three stage radio frequency sets of today, the selectivity is improved to a remarkable degree. In Fig. 6 for instance, we have three tuned circuits in series supplied with energy from an antenna coil. It is evident that the current in circuit C will not rise to a maximum unless all the circuits are adjusted to the same frequency. In this case, while the nearby high powered station may cause forced oscillations to be induced in circuit A they are not likely to be carried over into B and C unless the forced oscillation frequency is close to the natural frequency to which the circuits are tuned. This is the principle used in your neodyne set."

In a similar manner can we control the natural period of the electric circuit shown at B by varying the number of turns on the coil or by varying the capacity of the variable condenser. Of course, if we

(Turn to next page)

Here's Work That is Almost ROMANCE!



Many **EARN** \$50. to \$250. a Week in **RADIO**

Get into the great new BIG-PAY Industry—Radio. If you're earning a penny less than \$50 a week, clip coupon now. Send for AMAZING FREE BOOK. Be a Radio Expert, and draw down big money for the easiest and most fascinating work in the world. Positions everywhere. Need for Radio Experts in every community. Short hours. BIG PAY. Free book gives all the facts.

Learn Quickly and Easily At Home

Master Radio Engineers will show you how to qualify, quickly and easily at home, for Radio's big jobs. We guarantee to train you successfully. Everyday N. R. I.-trained men are taking good places in the Radio field. Thousands of openings now awaiting the trained men. FREE EMPLOYMENT SERVICE. Many other big features. Get the fact-CLIP COUPON.



"My charges for consultation \$2.50 per hour. All success due to you." A. R. Herke, Brooklyn.



"Radio a gold mine—your course worth thousands." A. R. Herke, Winipeg.

Get This Free Book!

Send coupon below for FREE BOOK "Rich Rewards in Radio." Read for yourself. No previous experience needed. Common schooling enough. WRITE NOW.



You get all these sets

Receiving sets, from simplest kind to thousand mile receiver, included to help you learn. An UNEQUALLED OFFER. Other special features for limited time only, so ACT QUICK!

NATIONAL RADIO INSTITUTE
Dept. BS7, Washington, D. C.

MAIL COUPON

National Radio Institute,
Dept. BS7, Washington, D. C.

Without obligating me in any way, please send me your free book, "Rich Rewards in Radio," also complete information on your practical, home-study Radio course.

Name.....

Address.....

Town..... State.....

Does your Radio enhance the beauty of your home?



GONE are the days when a radio set consisted of a bunch of wires, bulbs and unsightly batteries scattered all over the living room. Today beauty is the prevailing idea, and a radio set that does not fit in with the home's furniture harmoniously is considered out of date.

There is a "Pontiac" console table or beautiful cabinet for every standard design of radio set. Loud speaker may be included, and spaces are provided for batteries, where they may be out of sight. If your set has not been housed in a beautiful cabinet or console, now is the time to put that problem forever out of your mind.

Prices from \$25 Up

You may get a beautiful "Pontiac" console type radio table for as low as \$25, with loud speaker built-in. The unit, of course, is extra. Cabinets alone may be had for much less, while for the pretentiously-inclined, beautiful cabinets, blending with the finest furniture, may be had at a price within the reach of all.

Tell us your individual problem and let us tell you how much it will cost to beautify your radio and your home. All material used is the best mahogany and walnut. Or we will build to suit your own specifications. No obligation for this information. Our famous "Pontiac" Cabinets are used exclusively in all models of the new 1926 "Pontiac" Radio Frequency Receivers advertised in this issue of ON THE AIR.

Address

Pontiac Radio Co.

Cabinet Division

25 E. Jackson Blvd. Chicago, Ill.

COUPON

Pontiac Radio Co.,
25 E. Jackson Blvd.,
Chicago, Ill.

Gentlemen: At no obligation please send me information and prices on your () Radio cabinets—() or radio console tables with loudspeaker built-in.

Name.....

Address.....

(If special cabinet is desired, write your specifications on a separate sheet.) (2-25.)

The Function of the Coupler

(Continued from page 59)

supply enough energy, we could force an alternating current of some frequency other than the natural period of the circuit to flow, in the same way that we could force a rigid pendulum of the type shown in Fig. 3, to oscillate at some period other than that determined by its length, but in each case we would waste a great deal of energy.

Suppose now that we have two circuits loosely coupled (that is, quite far apart) as shown in Fig. 1 and that the frequency of the current in circuit A is maintained constant at its natural frequency. The circuit B, has an ammeter in it to show the value of the current flowing and also contains a variable condenser so that the natural period may be varied.

Approaching a Sharp Peak

"AS I HAVE already pointed out, the alternating magnetic field due to A induces a current in B of the same frequency as that flowing in A. If the variable condenser in circuit B is now adjusted so that this circuit has a natural period of the same frequency as that of the current flowing in A we will find that the ammeter in circuit B indicates maximum current. By slowly adjusting the variable condenser in circuit B from zero to maximum capacity we will find that as we approach a certain point the current as indicated by the ammeter gradually increases and after reaching a maximum it rapidly decreases. If we plot the current in section B in relation to the capacity of the variable condenser or more specifically in relation to the natural frequency of the circuit we will get a curve about as shown at 1, Fig. 4. That is, we will get a curve with a sharp peak if the degree of coupling is sufficiently loose.

If the coils are moved closer to each other, we have a different condition. You might expect since the field of circuit A linking with circuit B is stronger, that the current in circuit B will be greater. This, however, is not the case. Since the circuits are closely coupled we find that the secondary circuit B reacts upon circuit A. In other words, the current set up in circuit B by A will be in such a direction as to set up a field opposing the field produced by A and this effect will be stronger the greater the current flowing in circuit B. As the natural frequency of circuit B is increased from zero to maximum by means of the variable condenser we find that as we approach the resonance frequency, the current in circuit B gradually rises. As the current becomes stronger the opposing field also increases, correspondingly reducing the effective or inducing field.

"As a matter of fact, a point will be reached where the current in Circuit B will cease to grow or actually decrease as shown at 2 in Fig. 4. The closer the two coils are placed together the more marked will this effect be, as may be seen from Fig. 5, where curves 2, 3, and 4 represent successive degrees of coupling."

"Very well," interrupted my friend at this point; "supposing that is so, to what limits should this separation of coils be

carried? From the curves in Fig. 4 it appears that the further the coils are separated, the sharper will be the tuning and the greater will be the current in circuit B. Surely this must stop somewhere."

Reasoning It Out

"AND so it does, of course. Let us reason it out this way. Suppose we consider the two circuits a great distance apart. If we were mathematicians we would say at infinite distance from each other (mathematicians have a profound fondness for infinity), but as we are not mathematicians we will merely consider them let us say, a hundred feet apart. At this distance the field of circuit A linking with circuit B will be zero—in other words, the coils will have no effect on each other. If we now bring them together slowly we shall come to a point where the field of the primary circuit will cut the secondary circuit, inducing in the latter a current of very low intensity. As we bring the coils closer together more and more of the magnetic field of the primary coil will intersect the secondary resulting in a gradual increase in the strength of the current in the secondary. Finally, as the coils are brought still closer, the current in the secondary reached a value such that its field reacts upon the primary in the manner we have already described causing the effective field to be reduced.

"This point, where the secondary current no longer continues to increase as the coils are brought together, is called the point of critical coupling. This is shown graphically in Fig. 5, where it is seen that as the coupling is increased from zero, the value of the current in circuit B passes through a maximum.

"So there you have it. Nothing at all mysterious or difficult to understand, just a simple bit of reasoning which will be of tremendous help to you in getting the most out of your receiving set."

"Then, as I understand it," remarked my BCL friend, "the coupler in my receiving set must be adjusted to the critical value for best results."

"Exactly," said I, "All receiving sets today are provided with some form of coupling between the antenna and the grid circuit of the first tube which for best results must be adjusted to the critical value. In many cases this coupling is made variable so that the critical degree of coupling may be secured for any value of current in the aerial circuit. In most sets, however, the coupling is fixed, that is, the primary or aerial coil is wound on the same tube with the secondary or grid coil but separated from it by from a quarter of an inch to an inch, depending somewhat upon the number of turns of wire in the primary coil.

Andrew J. Kramer—

Is a regular contributor to ON THE AIR. You can follow his Papers every month and get a Call Book FREE for \$1.50

SEE PAGE 5 FOR DETAILS

Just What Does SLF Mean?

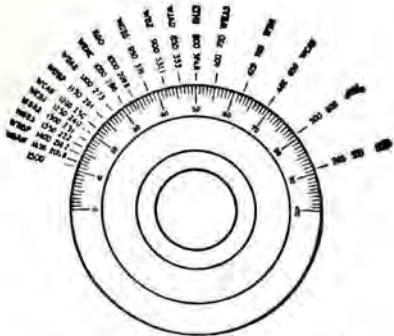

Figure 1

Pity the poor radio fan who is daily assaulted with new names with new radio terms and with the "latest" developments. A well known technical expert was once heard to remark that if he sat and inspected new apparatus eight hours a day, seven days a week, he would not check over one fifth of the "latest" pieces of apparatus on the market.

There are many ideas out of the many that appear in tangible form in apparatus design that have merit however. In the recent months the outstanding development in the condenser department of the radio industry has been the effort to manufacture a condenser that would simplify the tuning of a radio set on the higher frequencies (lower waves).

It is well known that the old condensers having a SLC (straight line capacity) curve crowded the stations at the lower end of the tuning range much in the manner illustrated in Figure 1. (Cut

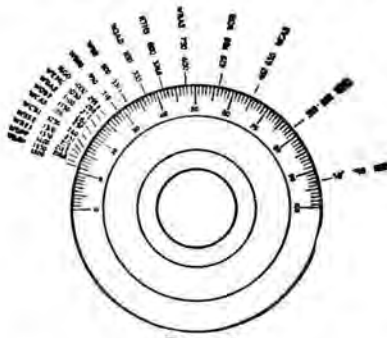

Figure 2

Engineers recognized this limitation on radio, and shortly after the broadcasting stations were reallocated, the SLW condenser (straight line wavelength) made its appearance. This simplified things to a greater or less extent but the crowding of stations on the lower frequencies became still more in evidence as the number of stations increased. The effect of using the SLW condenser improved the tuning of the set in the manner illustrated in Figure 2.

The wavelength allocating plan used by the secretary of commerce was rearranged into a system of assigned frequencies, with a band of 5 KC assigned to each radio station. This immediately brought forth a new condenser, called the straight line frequency which not only eliminated the crowding of stations on the lower waves but simplifies tuning as well. The tuning dial of a good SLF

condenser is much like the diagram in Figure 3 when it is logged. It is easy to see that all the stations are evenly distributed over the dial, making it much easier to tune them out.

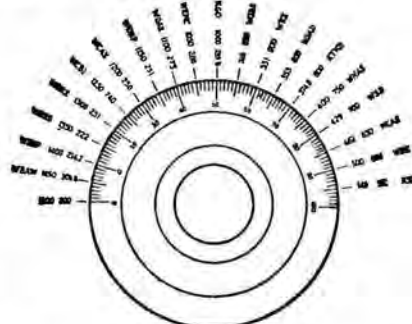
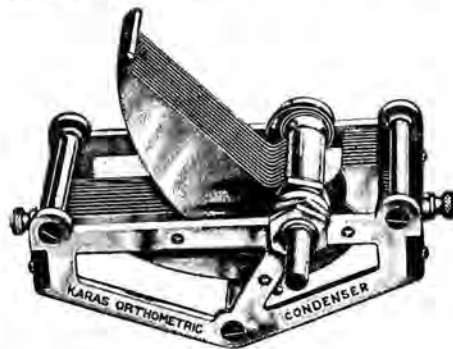

Figure 3

An excellent example of this SLF idea in design is that embodied in the New Karas Orthometric condenser. Reference to the drawing will disclose a long heart shape on the plates which is absolutely vital in getting true SLF characteristics.

A TYPICAL SLF CONDENSER

The condenser illustrated below is one of the best examples of the popular SLF tendency radio has taken to. Note the long heart shaped plates and the one hole mounting. This particular make is an excellent example of what a good variable condenser should be. It has brass plates soldered to the supports, a metal pigtail rotor contact and the insulating dielectric is so placed with respect to electrostatic field as to reduce losses to a minimum. The open end metal and plates cut down eddy current losses.



IN OUR NEXT ISSUE

- ☞ A Vivid, Absorbing Story of KFWB at Hollywood.
- ☞ WOAW's Funny BLAH Club.
- ☞ More Technical Surprises.

Don't Fail to Get Your Copy

When you build or rebuild

—select your parts most carefully. It is actually amazing what a marked improvement in radio results is obtained with Sterling "Soft Tread" Rheostats, Sterling Microcondensers, and Sterling Full Range Transformers. Testing is believing and we invite it.

Full Range Transformers



Soft Tread Rheostat

Balancing Micro Condenser



"Full Range" Transformer

Audio Frequency amplifying transformer covering entire range of audibility. Faithfully reproduces all audible vibrations, both high and low without distortion. Finest materials, compact, shielded, easy to wire, rich in appearance. List Price \$6.00.

"Soft Tread" Rheostat

The smooth running contact shoe insures free yet noiseless movement in either direction. Enclosed in dust-protecting bakelite and polished nickel case. Requires the drilling of only one hole on panel for mounting, 5, 6, 15 and 30 ohm. List Price \$1.25.

Microcondensers

that cure many a hopeless set. Two types, one the R-311 is invaluable for increasing the grid to plate capacity with 199 or 299 tubes and is extensively used for equalizing radio frequency circuits. The other, the R-312, is ideal for equalizing the capacity of imperfectly matched intermediate transformers and for single dial control. Highest grade clear mica, minimum loss. A necessity on many hook-ups. Adjustment is permanent and easily made.

R-311 max. capacity, 5 micro microfarads, \$1.00

R-312 max. capacity 40 micro microfarads \$1.50

See your Dealer or write

The Sterling Manufacturing Co.
(Cleveland, Ohio)

Sterling
RADIO PARTS

Big Saving on Your Magazines

MANY of our best club offers will soon be increased in price. Now is the time for the big saving. This big saving is good for a short time only. We will give prompt service if you mail your order without delay. It is to our mutual benefit if we receive your order now. Publisher's prices will soon increase and then our prices to you will be increased. Fill out the order blank and mail it today.

A Big Bargain of Magazines!

On the Air—12 issues

The Pathfinder—26 issues

The Home Magazine—12 issues

Radio Log and Call Book—

\$2
for only

On the Air

A MAGAZINE OF RADIO

October 1925

15 cents



- On the Air (1 yr.) The Home Magazine (1 yr.) Mother's Home Life (1 yr.) Home Folks (1 yr.) **\$1.50**
- On the Air (1 yr.) Peoples Popular Monthly (1 yr.) Mother's Home Life (1 yr.) Home Folks (1 yr.) Family Circle. On the Air. Poultry Keeper. **\$1.50**
- On the Air (1 yr.) McCalls (6 mos.) The Pathfinder (52 issues) Home Folks (1 yr.) **\$1.50**
- On the Air (1 yr.) McCalls Home Folks (1 yr.) **\$1.75**
- On the Air (1 yr.) The Pathfinder (26 issues) Family Circle. **\$1.75**
- On the Air (1 yr.) Pathfinder (1 yr.) **\$2.25**

- On the Air (1 yr.) Youth's Comp'n (26 issues) **\$2.60**
- On the Air (1 yr.) The Home Magazine (1 yr.) Radio Log and Call Book (1 yr.) **\$1.25**
- On the Air (1 yr.) The Home Magazine. Family Circle. Poultry Keeper (1 yr.) **\$1.50**
- On the Air (1 yr.) Mother's Home Life (1 yr.) Gentlewoman (1 yr.) Poultry Keeper (1 yr.) **\$1.25**
- On the Air (1 yr.) Farm Journal (1 yr.) Poultry Keeper (1 yr.) Home Folks (1 yr.) **\$1.25**
- On the Air (1 yr.) Successful Farming (1 yr.) Poultry Keeper (1 yr.) Home Folks (1 yr.) **\$1.25**

Send this Bargain Magazine Coupon

On the Air,
Kimball Hall, Chicago.

Enclosed find \$..... for one year's (state whether new or renewal) subscription to "On The Air." In addition to On the Air subscription my remittance includes payment for the following magazines:

.....
.....
.....

SEND TO

Name.....

Postoffice.....

State..... R. F. D.....

2-26

The Nationwide Fight Against Static

(Continued from page 14)

tion is at least worthy of further investigation.

Attributes Static to Full Moon

"I DISCOVERED that during the summer we frequently had nights free from static, despite warm, sultry weather. Invariably, such nights were those when the moon was in the first or last quarter. I discovered also that many nights which began with the atmosphere perfectly "dead," so far as radio reception was concerned, showed marked improvement later in the night when the moon had gone closer to the horizon.

"The night of December 28th of last year was a typical one. The air was crisp, cold and clear and there was no appreciable moisture—in spite of which it was impossible to pick up any but the most powerful distant stations and very few of those. The moon was just approaching fullness. For two hours it was impossible to hear anything but New Orleans and Pittsburgh. After midnight conditions improved and continued to get better until just before daylight when everything went dead again. I have noted similar conditions virtually every Monday night when the moon was full or high.

"I am not attempting to draw definite conclusions from my observations, the record of which is enclosed herewith. But I do believe the results are sufficiently interesting and of sufficient importance to the radio public to warrant an investigation of lunar influences on a comprehensive scale."

As a result of this letter, Mr. Smith sent out notices to the 4,000 observers who will take part in the February tests asking them to make notations during the period of the survey.

While the general drive is being conducted early in February to gather data on winter static, the tests will be continued throughout the year. Readers of ON THE AIR who are interested in becoming official listeners in these important tests are invited to write this magazine directly or to Mr. J. K. Smith of the Stewart-Warner Speedometer Corporation, 1826 Diversey Parkway, Chicago, for further details and recorder's blanks. At present the recording is largely being carried on by radio dealers throughout the nation, though broadcast listeners interested are invited to join in this progressive research, that will help to alleviate or eliminate the mysterious bane of radio—static and fading.

The Belden Manufacturing Company, 2300 South Western Avenue, Chicago, Illinois, have recently instituted a new method of merchandising radio terminals that meets with the favor of both dealer and consumer.

The terminals are now furnished in small, attractive display cartons containing 25 consumer packets per carton. This method saves time in making sales, prevents losses from pilfering, and provides a convenient means of handling.

The Voice of the Air Identified

(Continued from page 27)

trusive and unaffected enough under the 'nom de plume' of The Voice of the Air, they will like 'me as Phil Friedlander.'

"If I am at all successful in this interpretation of radio broadcast announcing, it is because the listeners appreciate the efforts of the artists.

Phil Friedlander broadcasts from WBBM and is the director of programs. Other members of his unusual staff are Sandy Meek, studio director; Harry Sosnick, musical director; Harold Morava, Edna Wheeler Ballard, Cantor Aaron Krietz and Ruby Rossini.

Regeneration Confused with Radiation

By POWEL CROSLY, JR.

MANY people have the mistaken idea that regeneration means radiation, or vice versa. This is not true. Regeneration and radiation are not synonymous, and should not be confused.

A radio set may contain regeneration in its circuit without offending by radiating. On the other hand, a so-called non-regenerative receiver may be, and frequently is, a most violent offender from radiation. A radio set radiates—sometimes improperly called "reradiates"—when the tube directly or magnetically connected to the antenna, oscillates and causes the antenna likewise to oscillate and give off energy.

While it is true that a single circuit regenerative receiver, having the detector directly connected to the antenna, can be made to radiate, no signals can be received while the tube is in a state of oscillation or radiation. Such sets generally use very low "B" battery potentials, thus reducing the power of radiation to a minimum, and furthermore, the control of oscillations is directly in the hands of the user, and with reasonably proper use, such sets cause but little interference, and only in a comparatively small short radius. On the other hand, many of the so-called non-regenerative tuned radio frequency sets, although perfectly balanced in the factory for certain types of tubes and at certain wave lengths, become the worst possible offenders—miniature broadcasting stations in effect, having high "B" battery potentials on the first radio frequency tube, and using tubes for which the set was not balanced, cause the uncontrolled condition of oscillations in the antenna, which causes serious continuous uninterrupted interference over a much broader radius.

RF Receiver Worst Offender

The difference between these two types of radio receivers is that a regenerative receiver in the state of oscillation, or in a state wherein it radiates, cannot receive broadcast signals and the oscillations must be controlled before satisfactory performance can be received. On the other hand, a tuned radio frequency receiver with its first tube in the state of oscillation while not performing satisfactorily, cannot be controlled, and, consequently, continually emits interference.

An ideal combination is a circuit wherein a muffler tube is used between a regenerative tube and the antenna. Thus regeneration can be used in a receiving set without any radiation. In this combination of regeneration and balanced radio frequency amplification, a receiver incorporating regeneration becomes the ideal type of receiver from the point of view of elimination of radiation, as well as taking advantage of the wonderful efficiency of regeneration in amplification, selectivity and volume.

So, again allow us to observe that radiation is not synonymous with regeneration.

Radio Parts Sets Kits at BIG SAVINGS



The Latest Hook-ups & Radio Catalog

New 1926 Radio Catalog & Builder's Guide brimful of new ideas—all free. Shows savings as high as 50% on sets and supplies. Get this thrifty illustrated book before you buy. It means money in your pocket. Standard guaranteed goods. Write letter or postal note. Also please include name of radio friend.

BARAWIK CO.

102-119 S. Canal St.,
Chicago, U. S. A.

How to Get the Most Out of Your Set



Learn the principles of radio from this remarkable book
514 PAGES

Compiled by HARRY F. DART, E.E.
Formerly with the Western Electric Co., and
U. S. Army Instructor of Radio
Technically edited by F. H. DOANE

STOP turning the dials blindly. Learn what happens when you turn them and why. Then you will get greater distance, greater volume, most enjoyable quality. The I. C. S. Radio Handbook will help you to get more enjoyment out of radio. It clears up the mysterious—tells you just what you want to know. Written by nationally known radio authorities in language that you can understand. An absolute necessity for every radio fan. A wonderful bargain at \$1. Note this partial list of contents—

Electrical terms and circuits, antennas, batteries, generators and motors, electron (vacuum tubes), many receiving hook-ups, radio and audio frequency amplification, broadcast and commercial transmitters and receivers, super-regeneration, licenses, etc.

Send only \$1 with the coupon today and get this 514-page I. C. S. Radio Handbook.

Money Back if Not Satisfied

International Correspondence Schools
Box 7836 Scranton, Penna.

I enclose \$1. Please send me—post-paid—the 514-page I. C. S. Radio Handbook. It is understood that if I am not entirely satisfied I may return this book within five days and you will refund my money.

Name.....

Address.....

Check here and enclose \$1.50 instead of \$1 if you wish the De Luze Leatheroid Edition

Free Mailing Lists

Will help you increase sales. Send for FREE catalog giving counts and prices on thousands of classified names of your best prospective customers—National, State and Local—Individuals, Professions, Business Concerns.

99% Guaranteed 5¢ each by refund of

ROSS-GOULD CO.

10th St. St. Louis

CARTER

"IMP" Rheostat \$1

All Resistances, 5 to 60 ohms.
Works efficiently in any circuit.

Carter Radio Co.

300 S. Racine Ave. CHICAGO

RADIO AGENTS WANTED

5 Tube Demonstrator FREE!

Earn \$25 to \$100 a week, part or full time. Everyone a prospect. Complete line standard sets and accessories, \$6 to \$90. Write today for illustrated catalog and exclusive selling plan for live dealers and community agents. 20TH CENTURY RADIO CO., 1273 Coca Cola Bldg., Kansas City, Mo.



Clarity

Volume

Beauty

PRICES

Three Finishes

\$22.50 \$25.00 \$30.00

Burns

FOR REAL ENJOYMENT

Use the BURNS Loud Speaker on your receiving set. Produces utmost in volume and clarity of tone. Reaches full range of musical scale—equal to hearing the original production.

At your dealers or direct

American Electric Company

State and 54th Streets Chicago



PRICE
\$15

The Clearest Tone You've Ever Heard

THAT will be your sensation when you hear the new Baumgart "Natural-Tone" Loud Speaker, which has been declared the marvel of recent radio shows since its introduction a month ago. Note the unique design, the compact arrangement, and all-round efficiency. The specially built wooden tonal chamber reproduces broadcast music and speech with clarity and faithfulness to be found only in the phonograph. Indeed, the principle is somewhat the same. And the price is only \$15! Encased in a beautiful mahogany cabinet, with handsome scroll backed by a gold silk screen. Hear this wonderful "Natural-Tone" speaker at your dealer's, or send \$15 direct and we will ship you one of these speakers immediately.

BAUMGART NATURAL-TONE LOUD SPEAKER

F. G. BAUMGART CO.

4556-68 W. GRAND AVE. CHICAGO, ILL.

Sales Representatives

THE RADIOGRAPH CO. 210 E. Ohio St., Chicago, Ill.

A Few Choice Dealer Territories still Available.

FREE RADIO STAMPS

168 beautiful copper etched American, Canadian, and European stamps, each with the call letters of a station. FREE with Ideal 48-page Radio Stamp Album and Log. Also contains complete list of stations both alphabetically and by call letters. As you hear new stations, just put the proper stamps in your album. Album and stamps become a permanent and interesting record of the stations you receive. You and your children will enjoy it. Complete album, 8" x 11", heavy board covers, \$1 plus postage.

Send No Money

Just pay postman after album and stamps arrive. We prepay postage if you prefer to pay with order. MONEY REFUNDED if not DELIGHTED. Send order today—NOW. Postal will do. IDEAL CO., Dept. 2219 366 Wrigley Bldg., Chicago



can hear all the conversation in the room where the loud-speaker is.

No batteries are used but simply the two insulated wires from the loud-speaker terminals to the head-phones. This can be used for a very amusing demonstration of "thought-reading." A person in the room where the loud-speaker is situated is asked to name an article, or a song title or a well-known phrase or line of poetry, and the audience is told to concentrate their minds on it while the "thought-reader" is out of the room—and, of course is secretly listening-in on the telephones. To eliminate any chance of mistake a confederate may repeat the name or words decided upon once or twice—presumably for the benefit of the assembled company. On returning to the room the "thought-reader" should not have much difficulty in "picking-up" the thought waves!

The Thorola Coils

A GOOD aerial is like an active puppy; it brings in everything it can pick up. Then by means of a variable condenser the listener can tune this antenna system so that he will hear only the station which he wants and he shouldn't be annoyed by any of the stray pick ups.

But the average radio set is practically a whole kennel of active puppies. The antenna picks up, as it should; the coupler windings pick up, as they shouldn't, the radio frequency transformer windings add to the input of signals by bringing in their very own and in conflict with all others. Result—the listener finally comes to the disheartening conclusion that his receiver is not selective.

Recently radio engineers have turned their attention to some means of preventing all these undesired pick ups by windings in the receiver. As one engineer recently exclaimed "a radio set that will operate without a ground or antenna is like a leaky roof; everything pours in."

Hill and Vale Winding

Only one form of coil has so far been found that will not pick up signals, even from powerful nearby stations. It is the toroid, or doughnut coil. Early development in this coil was held back because in its usual form of winding, with all wires paralleling, it was found to greatly increase the capacity. Recently one of the radio engineers, of the Reichmann Company, worked out a new form of toroid coil. Since then tests have shown that it is a distinct advancement in the science of radio reception.

A tuned radio frequency set using one type of doughnut coil as a coupler and two doughnuts of slightly different type as radio frequency transformers was taken to within 200 feet of a 1,000 watt broadcasting station. The set without antenna or ground wire connections would not pick up the slightest signal from the station. With antenna and ground attached the set brought in a distant station ten meters away from the wave length of the nearby powerful station.

Aside from increasing the selectivity of the receiving set in which the doughnuts are used, they also do away with a lot of the noises which comes from interfering magnetic fields within the set. Any "open type" coil will spray its magnetic field. It is for this reason that most coils have to set at different angles and well apart. The doughnut coils can be set close together and all at the same angle for the reason that the magnetic field in each is completely confined and cannot spray.

Exhaustive tests have also shown that the volume of the average of practically every circuit, from the one tube ultra-audion to the five tube neotrodyne, is improved by the use of the doughnut coils.

RADIO LOG and CALL BOOK
FREE

Read the offer on page 5

Feed Backs

(Continued from page 48)

room and running a pair of wires from it to head-phones in another room you

Say "MUSSELMAN" When You Buy Tubes

You will notice that pleasing surge of elusive DX power and sensitivity in your loud-speaker when you turn on the filaments

WHY is there such an increase of microphonic noises and defective tubes? Why are un-uniform tubes so frequently encountered? Why is the performance of a radio so impaired when the tubes are changed around in the set?

The Engineers answer is something like this:

Good reception depends on a good receiving set and an efficient circuit embodied therein, and what is equally important, efficient tubes. To get maximum results we must use tubes that have the proper characteristics.

The characteristics of a tube can only be known from an actual laboratory test, in which a curve is plotted giving mutual conductance, amplification constant and plate resistance. In making these tests, and in plotting these readings the tube can be classified into a definite use where its efficiency is greatest.

That explains the time worn phrase "try changing the tubes around in the sockets." It is nothing more than an admission that you are guessing at the abilities of the tube.

The Musselman Sales Policy Eliminates Guessing

If you think your set is only giving indifferent results because of the tubes, you owe it to yourself to check up on this fair tube selling policy.

With each Musselman tube an individual chart is enclosed in the carton, giving detailed readings on its characteristics. You can tell at a glance which tube is the best for your purpose.

What radio men say about the necessity of **KNOWING** the tube used.

By **ANDREW KRAMER**
in *On The Air*

"In testing a vacuum tube, what we wish to know is the manner in which the current in the plate circuit varies when the voltage of the grid circuit is changed. This is an absolute necessity in precision results."

By a well known
TECHNICAL EDITOR.

"The only sure way to determine the actual efficiency of a tube is to take two readings with different values of grid voltage, and determine the change in plate current

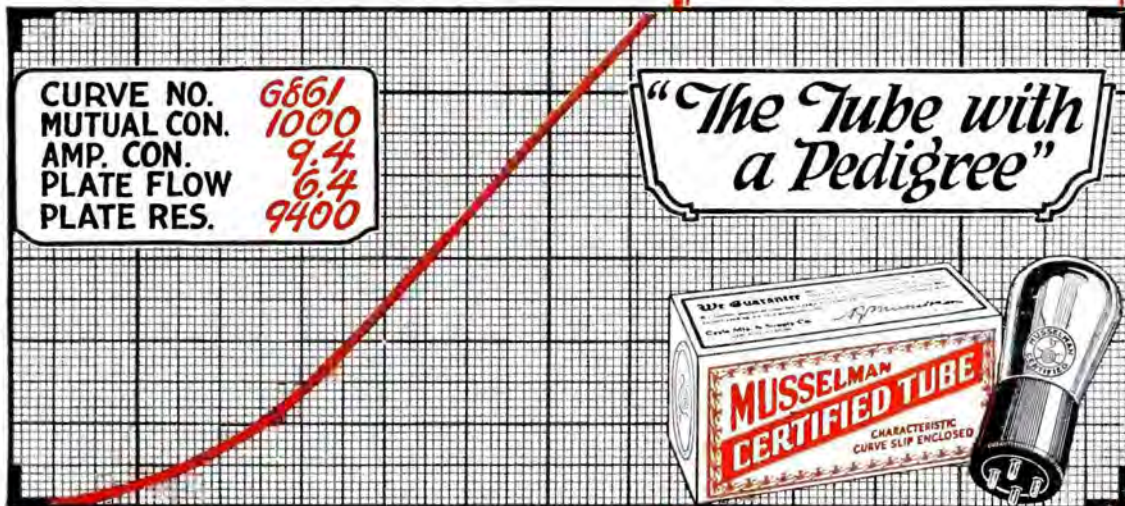

The possibility of getting a defective tube is removed, the necessity of changing sockets is obviated (there are thousands of combinations and permutations) and further you definitely know that your set is at its best because you are employing the right tubes in the correct socket. You insure satisfaction and make results a certainty when you buy Musselman Tubes because **YOU KNOW JUST WHAT YOU ARE BUYING.**

caused by a given change in grid voltage. This gives the true amplification ratio of a tube and is the accepted method of getting the grid voltage plate current characteristic which is the key to tube performance."

The above chart is a sample taken from the carton of a Musselman tube. It shows the tube to be uniform and that it will perform efficiently as an amplifier.



The new Musselman Mogul Power Amplifier for that overloaded last audio stage. A novel strap arrangement makes it universal in use. Write for details.

Write for our instructive booklet on tubes

MUSSELMAN CERTIFIED ELECTRON TUBES

A. J. MUSSELMAN INC.

655 Machinery Hall

Chicago, Ill.

**No matter what circuit—
Far, Far Better Results
with**

KARAS

Orthometric Condensers and Harmonik Transformers

KARAS instruments have been tested and recommended by leading technical editors for use in all types of sets from the most elaborate supers to the simplest low loss 3-tube receivers. The most exacting home set builders, the country over, demand Karas Transformers and Condensers—and will use nothing else. Nothing can take the place of these scientifically designed, precision instruments. Use them in your next set—or improve your present set by installing them. It's easy to do—the results will be worth many times the cost.

**Spreads Stations Evenly
Over the Dial
—No Crowding
Whatever!**

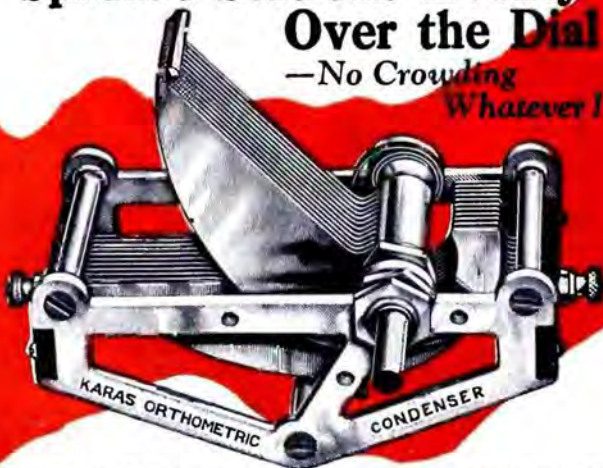

The Karas Orthometric Condenser positively separates all adjoining wavelengths by EQUAL distances on the dial—giving you full benefit of the 10 Kilocycle frequency separation fixed by the government. Ordinary condensers jam 70 of the 100 Government allotted wavelengths into the first 30 points on the dial—even straight-line-wavelength condensers crowd 57 of them below 30. But with Karas Orthometrics, each point on the dial corresponds to one of the 100 allotted wavelengths. The result is marvelous simplicity in tuning—and better, clearer reception—all side bands without interference.



**For Long Distance
with Big Volume and
Keen Musical Quality**

Karas Harmoniks deliver perfect music with loads of volume from stations one to two thousand miles distant. DX broadcasting becomes really enjoyable. "Fishing" for distant stations is only a matter of finding programs you want to hear—not straining to catch only the bare announcement and making up a list of call letters.

Even from far away points, Karas Harmoniks bring out full, round musical tones. All the vital harmonics and rich overtones are fully retained. Low bass notes pour forth, rich, sweet, sonorous. If you want music like this, you must have Karas Harmoniks in your set. Get a pair TODAY!

KARAS ELECTRIC CO. (Plant: N. Rockwell St.
1082 Association Building
Chicago, Illinois.)

Please ship me the instruments checked below. I will pay the postman prices listed, plus postage upon delivery. It is understood that I have the privilege of returning these goods, for full refund, within 30 days, if they do not prove entirely satisfactory.

.....Karas Harmonik Audio Transformers. (\$7.00 each)

.....Karas Orthometric Condensers: Size.....
(23 plate \$7 ea.; 17 plate \$6.75 ea.; 11 plate \$6.50)

Name.....

Address.....
If you send cash with order, we'll send package postpaid

Brings in KDKA at 53

Not at 17—or 28, but at 53 where it belongs, leaving lots of room for the 52 wavelengths that must come in below it. The Karas Orthometric is a "precision job"—entirely of brass. Every joint soldered. Plates patent-levelled and securely bridged.

If your dealer is out of Karas Instruments

Order Direct on This Coupon

Most good dealers everywhere sell Karas parts. If your dealer happens to be one who doesn't, we will supply you direct at no trouble on your part—on our 30-day money back guarantee. Just fill in and mail this coupon at once. Send no money. You can pay the postman on delivery.

KARAS ELECTRIC CO., Manufacturing Plants: N. Rockwell St.
Offices: 1082 Association Building,
CHICAGO, ILLINOIS

For more than 30 years makers of PRECISION Electrical Apparatus

This file including all text and images are from scans of a private personal collection and have been scanned for archival and research purposes. This file may be freely distributed, but not sold on ebay or on any commercial sites, catalogs, booths or kiosks, either as reprints or by electronic methods. This file may be downloaded without charge from the Radio Researchers Group website at <http://www.otrr.org/>

Please help in the preservation of old time radio by supporting legitimate organizations who strive to preserve and restore the programs and related information.